

WHEEL END



STEMCO® WHEEL END CATALOG



STEMCO®

Making the Roadways Safer®

— An ENPRO Company —



TABLE OF CONTENTS

VMRS Codes	2
Axle Application Graphics	3
Application Chart	4
Platinum Performance Systems	6
Quick Reference	7-11
Internal Hub Seal	7
Axle Ring to Hub Seal	7
Standard and Grit Guard® Hub-Seal to Set	8
Heavy Duty Bearings	9
Bearings to Hub Seal Set Cross Reference	10
Seal Sets Section	12-27
Trailer Axles	13
Steer Axles	17
Drive Axles	22
Component Specifications Section	28-51
Grit Guard® Deflector Ring Specifications	28
Oil Seal Specifications	29
Hub Cap Specifications	32
Sentinel® Technology	38
Flange Gasket Specifications	45
Defender™	46
Mileage Solutions	48
DataTrac® Pro	50
Hubodometer®	51
Hubodometer® Specifications	51
Installation Tools Section	52-59
Universal Axle Tool	52
Universal Axle Tools (555-Series)	54
Fleet Hub Tools (551-Series)	55
Heavy Duty Axle Tools (552-Series)	57
Axle Fastener Interchange Guide	60-61
Cross Reference Section	62-97
Installation Instructions	98-112
Bearing Removal and Installation	99
Wheel Bearing Adjustment	100
Discover® XR/Voyager® Hub-Seal Installation	101
Guardian®/Guardian®HP Installation	102
Standard/Grit Guard® Seal Installation	103
Auto-Torq® Installation	104
ZIP-TORQ® Installation	105
PRO-TORQ® Installation	107
Hub Cap Installation and Troubleshooting	109
DataTrac® PRO Installation	111
DataTrac® SVT Installation	112
Total Quality Maintenance	113

VMRS CODES

PRODUCT	DESCRIPTION	ATA/VMRS CODE*	STEMCO PART NO. SERIES
Axle Rings	Drive	18-002-014 (STMCO)	310-1000 Series
	Dead	18-001-015 (STMCO)	
Bearing Spacers		18-001-013 (STMCO)	357-5700 Series
Gaskets		18-003-017 (STMCO)	330-3000 Series
Grit Guard® Deflector Rings	Drive	18-002-014 (STMCO)	315-1500 Series
	Dead	18-001-015 (STMCO)	
Hub Caps		18-003-003 (STMCO)	300-, 303-, 340-, 342-, 343-, 348-, 349-, 350-, 352-, 353-, 356-, & 358-0000 Series
Hubodometers		51-002-002 (STMCO)	650-0000 Series
Hubodometer Brackets		51-002-002 (STMCO)	610-0000 Series
Hubodometer Hub Caps		51-002-004 (STMCO)	640-0000 Series
Locating Rings		18-001-013 (STMCO)	356-5600 Series
Misc. Components (including Hub Cap Parts)		None	359-5900 Series
O-Rings		18-003-015 (STMCO)	355-5500 Series
Oil Seals (Standard)	Drive	18-002-005 (STMCO)	320-2000 Series
	Dead	18-001-004 (STMCO)	
Oil Seal Sets:	Drive Axle	18-002-028 (STMCO)	392-9000 Series 309-0900, 391-, 393-0000 Series
	Front Axle	18-001-026 (STMCO)	382-8000 Series 308-0800 & 383-0000 Series
	Trailer, Tag or Pusher Axle	18-004-001 (STMCO)	372-7000 Series 307-0700 & 373-0000 Series
Zip-Torq®	Drive Axle	012-001-005	400-4900 Series
	Trailer, Tag or Pusher Axle	012-002-005	447-4700 Series
Pro-Torq®	Drive Axle	012-001-005	449-4900 Series
	Trailer, Tag or Pusher Axle	012-002-005	447-4700 Series
Auto-Torq		012-002-005	480-4723 & 4743
		012-001-005	480-4973
Shoulder Bushings		18-001-013 (STMCO)	364-6400 Series
Tools	Fleet Hub Tools	None	551-5300 Series
	Heavy Duty Axle Tools	None	552-5200 Series
	Universal Tool Body & Accessories	None	555-0000 Series
	Universal Tool Heads	None	555-5000 Series

* American Trucking Association/Vehicle Maintenance Reporting Standards

AXLE APPLICATION GRAPHICS

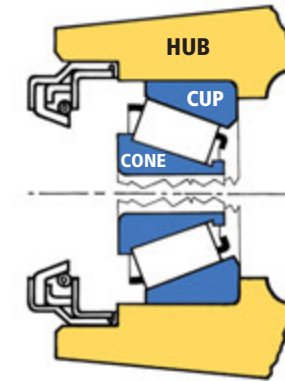

NOTICE

Some STEMCO hub seals are not designed to fit into the seal bore of the hub as the one shown at the left, but are properly sized to fit into the same bore as the bearing cup, as shown on the right. Always refer to the instructions packaged with the seal.

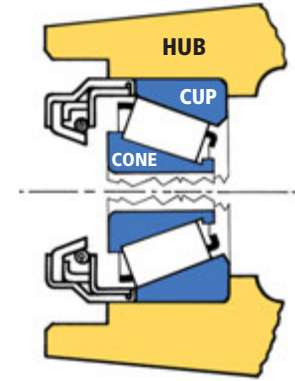

OIL FLOW with wheel rotation provides positive lubrication to bearings and spindle.

GUARDIAN® SEAL bonded rubber O.D. provides positive seal in bore – overcomes minor bore imperfections.

TYPICAL TRAILER AXLE APPLICATION

Corresponding Grit Guard® Set with Deflector Ring

PROPER LUBRICATION allows the bearing cone to creep on a film of oil and distribute the wear and load for the FULL life of bearing.

RELIABILITY — STEMCO Hub-Seals are designed specifically for wheel application with any type oil.

A BATH OF LIQUID OIL dissipates heat and provides instant lubrication in all weather.

OIL FLOW with wheel rotation provides positive lubrication to bearings and spindle.

PROPER LUBRICATION allows the bearing cone to creep on a film of oil and distribute the wear and load for the FULL life of bearing.

GUARDIAN® SEAL bonded rubber O.D. provides positive seal in bore – overcomes minor bore imperfections.

TYPICAL DRIVE AXLE APPLICATION

Corresponding Grit Guard® Set with Deflector Ring

RELIABILITY — STEMCO Hub-Seals are designed specifically for wheel application with any type oil.

A BATH OF LIQUID OIL dissipates heat and provides instant lubrication in all weather.

APPLICATION CHART

APPLICATION	GUARDIAN® GUARDIAN®HP	GRIT GUARD® STANDARD	VOYAGER®	DISCOVER® XR
19,000# Trailer Axle Standard Forge, Dana, Meritor, Eaton	307-0713 ⁵	372-7098	373-0113	
Pro-Par Trailer Axle, Fruehauf, Eaton P-22, Meritor TP, Dana	307-0723 ⁵	372-7099	373-0123	373-0423
22,500# Trailer Axle, Meritor, Standard Forge, Dana, Eaton	307-0743 ⁵	372-7097	373-0143	373-0443
20,000# Trailer Axle, Meritor, Shuler	307-0744	372-7095	373-0144	
12,000#, 14,600# Meritor Front Transit GMC F-120 to 1985			383-0101	
12,000# Front Axle, Meritor, Eaton, Ford, Freightliner, Kenworth, Western Star, Navistar, Peterbilt, Volvo GM	308-0836 ⁵	382-8036	383-0136	383-0436
12,000# Mack Front Axle			383-0139	
Navistar Front Axle, FA 309, FA 329	308-0853			
9,000# Front Axle, Navistar, FA 109 Cast Wheel '79 and up	308-0855		383-0156	
12,000# Front Axle, Navistar			383-0156	
7,000#, 9,000# Front Axle, Ford	308-0863			
16,000# Front Axle, Ford, Navistar, Mack, Meritor, White, Kenworth, Western Star, Peterbilt, Volvo GM	308-0864 ⁵	382-8064	383-0164	383-0464
6,000#, 7,500# Front Axle, Navistar	308-0866	382-8066	383-0166	
Volvo FA 7.5 Front Axle	308-0870			
GMC F-120 1985 and up			383-0171	
8,000# GMC Front-Top Kick				
11,000# GMC Front-Top Kick				
34,000# Drive Axle, Mack	309-0903 ⁵	392-9094	393-0103	
44,000# Drive Axle, Mack	309-0904 ⁵	392-9112 392-9130	393-0104 393-0104	
34,000# Drive Axle, Eaton, Ford, Navistar, White	309-0912 ¹	392-9099	393-0112	
17,000# Single and 34,000# Tandem, GMC		Refer to above 392-9099 set		
Meritor Drive-Transit			393-0134	
15,000# Drive Axle, Ford, Meritor F-Series	309-0935			
Mack Drive Axle 50,000# and 60,000#	309-0948	392-9089	393-0148	
38,000# Drive Axle, Mack, GMC, Eaton, Meritor		392-9132 ²		
Van Hool Bus	391-9066	392-9066		
38,000#, 40,000# and 42,000# Tandem Drive Axles, Ford, Eaton, GMC, Mack, Navistar, White		392-9092 ³ 392-9096		
38,000# Drive Axle, Eaton, Meritor, White		392-9087		
38,000#, 46,000# Tandem Axles, Eaton, Ford, Freightliner, Kenworth, Western Star, Peterbilt, Meritor, Navistar, Volvo GM	309-0973 ⁵	392-9131 ⁴	393-0173	393-0423

¹ Use with 5.687" Bore Only.
² Does not fit Mack Applications.
³ Fits Mack Application Only.
⁴ Use with Wabco ABS.
⁵ HP Design

APPLICATION CHART

GG/STANDARD COMPONENTS SEAL/RING	INNER BEARING	UNIVERSAL AXLE TOOL HEADS 2	UNIVERSAL HUB TOOL HEADS 3	BEARING GUIDE
2109/1507	663	555-5100	551-5313	570-0023
2023/1503	HM518445	555-5023	551-5401	570-0025
2110/1504	HM218248	555-5039	551-5412	570-0026
2118/1510	665A	555-5069	551-5339 ⁹	570-0024
2086/1013	6386 or 6389, 6379	555-5060 or 555-5014	551-5420 ⁸	570-0020 ¹⁰
2034/1034	HM212047	555-5066	551-5387	570-0019
2036/1036	39581	555-5062	551-5346	570-0017
	HM212044	555-5061	551-5346	570-0018
	HM212049, -X, X1	555-5098	551-5346	570-0020
2039/1038	HM212047	555-5066	551-5346	570-0019
	641 or HM212049	NONE REQ'D	551-5413 ¹	570-0020
2181/1093	641 or HM212049 H715345	555-5060 555-5070	551-5419 551-5419 ⁴	570-0020 570-0021
2199/1093	641	555-5060	551-5344	570-0020
2199/1093	H715345	555-5070	551-5344	570-0021
2133/1036 45284	39581	555-5062	551-5353	570-0017
	555-5064	551-5353		
2137/1037	6461A	555-5007	551-5327	570-0022
2164/1008	JM207049	555-5088	551-5423	570-0036
	JM205149	555-5089	551-5423 ⁷	570-0033
2216/1034	JF7049A	555-5297		
	HM212047	555-5066	551-5403	570-0019
	JM205149		551-5417	570-0033
	33212		551-5418	570-0031
2129/1511	580 or 582	555-5072	551-5415 ²	570-0023
2213/1515 2213/1519	663 or HM516449, -C	555-5072	551-5414 ³	570-0023
	HM516449A	555-5073	551-5414 ³	570-0023
2102/1501	47685 or 47686	555-5031	551-5416 ⁵	570-0023
	47678 or 5760	555-5074	551-5416 ⁵	570-0022
	47686	555-5031	551-5424	570-0023
2061/1066	6580 or 6559	555-5023 or 555-5072	551-5421 ⁶	570-0025 or 570-0023
2057/1062	33287	555-5011	551-5353	
2097/1516	687 or 780	555-5004	551-5400	570-0032
2115/1530	598A	555-5071	551-5356	570-0027
	594A	555-5076	551-5356	570-0028
2115/1107	594A	555-5076	551-5356	570-0028
2131/1508	598	555-5071	551-5363	570-0027
2114/1508	595	555-5072	551-5412	570-0023
	598	555-5071	551-5412	570-0027
2162/1502	683XA or 683	555-5076	551-5333	570-0028
	681A	555-5071	551-5333	570-0027
2106/1525	594 or 594A	555-5076	551-5320	570-0028
	598 or 598A	555-5071	551-5320	570-0027

¹ Use 551-5395 for 320-2039 seal. ⁶ Use 551-5356 for 320-2061 seal.
² Use 551-5393 for 320-2129 seal. ⁷ Use 551-5366 for 320-2164 seal.
³ Use 551-5364 for 320-2213 seal. ⁸ Use 551-5311 for 320-2086 seal.
⁴ Use 551-5349 for 320-2181 seal. ⁹ Use 551-5321 for 320-2118 seal.
⁵ Use 551-5318 for 320-2102 seal. ¹⁰ Does not fit 6379.

PPS SOLUTIONS PROVIDE THE INDUSTRY'S BEST WARRANTY

Platinum Performance System™ solutions provide exceptional performance and reliability, but it's their warranties that provide peace of mind for fleet owners and managers. And the more innovative STEMCO® products that are added to the package, the longer the warranty and the greater the peace of mind.



PLATINUM PERFORMANCE SYSTEM WARRANTY PACKAGE OVERVIEWS

OEM PACKAGES	TRUCK	TRAILER ¹
PART	PLATINUM PERFORMANCE SYSTEM PLUS	PLATINUM PERFORMANCE SYSTEM PLUS
STEMCO Discover XR or GHP Seal	✓	✓
STEMCO Bearings	✓	✓
STEMCO Auto-Torq, Pro-Torq, or Zip-Torq	✓	✓
STEMCO Sentinel Hub Cap	✓	✓
Warranty Coverage	5-year parts & labor	7-year parts & labor
Mileage Coverage	500,000 MILES or 800,000 KM	UNLIMITED MILEAGE

AFTERMARKET PACKAGES	PLATINUM PERFORMANCE SYSTEM		PLATINUM PERFORMANCE SYSTEM PLUS	
PART	TRUCK	TRAILER	TRUCK	TRAILER
STEMCO Discover XR or GHP	✓	✓	✓	✓
STEMCO Bearings			✓	✓
STEMCO Auto-Torq, Pro-Torq, or Zip-Torq	✓	✓	✓	✓
Any STEMCO Hub Cap with Sentinel Technology	✓	✓	✓	✓
Warranty Coverage	3-year parts only		5-year parts & labor*	
Mileage Coverage	350K miles / 560K KM	Unlimited miles / KM	500K miles / 800K KM	Unlimited miles / KM

1. Warranty coverage for intermodal chassis is 5 years, unlimited mileage, parts and labor.

2. Warranty coverage for intermodal chassis is 3 years, unlimited mileage, parts and labor.

*Extended warranties are for On Highway applications only.

**See STEMCO Tech Tip #21 for recommended inspection and Service Intervals for STEMCO Systems.

***See STEMCO Tech Tip #34 for a list of approved lubricants.

****OEM parts coverage is limited to the replacement part, lubricant, hub cap gasket, and Pro-Torq keeper (if applicable). AM parts coverage is limited to the replacement part only.

*****Labor coverage is limited to 1 hour per seal, 1 hour per bearing set, 1/2 hour per axle fastener, or 1/4 hour per hub cap (not cumulative).

INTERNAL HUB SEAL CROSS REFERENCE

GUARDIAN® / GUARDIAN®HP SEAL NO.	INNER BEARING CONE	UNIVERSAL TOOL HEAD	STANDARD/ GRIT GUARD® SET	VOYAGER® DISCOVER® XR
307-0713 ¹	663	555-5100	372-7098	373-0113
307-0723 ¹	HM518445	555-5023	372-7099	373-0123 373-0423
307-0743 ¹	HM218248	555-5039	372-7097	373-0143 373-0443
307-0744	665A	555-5069		373-0144
308-0836 ¹	39581	555-5062	382-8036	383-0136 383-0436
	HM212044, 557A	555-5061		
	HM212049, -X	555-5098		
	HM212047	555-5066		
308-0853	641	555-5060		
	HM212049	555-5060		
308-0855	641	555-5060		
	H715345	555-5070		
308-0863	39581	555-5062		383-0156
	45284	555-5064		
308-0864 ¹	6461A	555-5007	382-8064	383-0164 383-0464
308-0866	JM207049	555-5088	382-8066	383-0166
	JM205149	555-5089		
308-0870	JF7049A	555-5297		
309-0903 ¹	580	555-5072	392-9094	393-0103
	582			

¹ Use Universal Tool Body 555-0001 with 555 Series Tool Heads.

GUARDIAN® / GUARDIAN®HP SEAL NO.	INNER BEARING CONE	UNIVERSAL TOOL HEAD	STANDARD/ GRIT GUARD® SET	VOYAGER® DISCOVER® XR
309-0904 ¹	663 HM516449, -C	555-5072	392-9112	393-0104
309-0912	47685 47686	555-5031	392-9099	393-0112
	47678 5760	555-5074		
	47685 47686	555-5031		
309-0935	33281 Thru 61	555-5002		
	33287 62 Up	555-5011		
309-0948	687 780	555-5004	392-9089	393-0148
	594A	555-5076	392-9132	
598A	555-5071			
	595	555-5072	392-9096	
	598	555-5071		
	683XA 683	555-5076		
	681A	555-5071	392-9087	
	594 594A	555-5076	392-9131	393-0173 393-0473
	598			
598A	555-5071			

AXLE RING TO HUB SEAL SET CROSS REFERENCE

AXLE RING	OIL SEAL	HUB-SEAL SET
310-1008	320-2164	382-8066
310-1022	320-2023	372-7022
310-1036	320-2036	382-8036
310-1022	320-2023	372-7022
310-1043	320-2041	372-7015
310-1063	320-2057	392-9036
310-1064	320-2136	372-7049
310-1089	320-2099	392-9053
310-1130	320-2023	372-7062
315-1501	320-2102	392-9099
315-1502	320-2162	392-9087
315-1503	320-2023	372-7099

AXLE RING	OIL SEAL	HUB-SEAL SET
315-1503	320-2173	372-7091
315-1504	320-2110	372-7097
315-1506	320-2111	372-7096
315-1507	320-2109	372-7098
315-1508	320-2114	392-9096
315-1510	320-2118	372-7095
315-1511	320-2129	392-9094
315-1515	320-2213	392-9112
315-1516	320-2097	392-9089
315-1519	320-2213	392-9130
315-1525	320-2106	392-9131
315-1530	320-2115	392-9132

STANDARD AND GRIT GUARD® HUB-SEAL TO SET CROSS REFERENCE

STEMCO QUALITY BEARING REFERENCE GUIDE

QUICK REFERENCE

OIL SEAL	AXLE RING	HUB-SEAL SET	INNER BEARING #	UNIVERSAL TOOL HEAD	HUB TOOL	COMMENT
320-2023	310-1022	372-7022	593	None	551-5401	I-Beam Axle Model 5
	310-1130	372-7062	592A or 593	555-5023	551-5401	Modified No. 5 ¹
	315-1503	372-7099	HM518445	555-5023	551-5401	Grit Guard® for Pro-Par only
320-2036	310-1036	382-8036	557A or HM212044	555-5061	551-5346	
			HM212047	555-5066	551-5346	
			HM212049	555-5098	551-5346	
			HM212049X	555-5098	551-5346	
320-2041	310-1043	372-7015	759	555-5023	551-5398	C&M K-30 Std. Forge TA- 26, A-26-S
320-2057	310-1063	392-9036	33281	555-5002	551-5353	
320-2097	315-1516	392-9089	687 or 780	555-5004	551-5400	
320-2102	315-1501	392-9099	47685 or 47686	555-5031	551-5318	Grit Guard® ¹
			47678	555-5074	551-5318	
			45284	555-5064	551-5351	
320-2106	315-1525	392-9131	598 or 598A	555-5071	551-5320	Grit Guard® Used with or without Wabco ABS
	315-1507	372-7098	663	555-5100	551-5313	Grit Guard®
320-2110	315-1504	372-7097	HM218248	555-5039	551-5412	Grit Guard®
320-2111	315-1506	372-7096	787	555-5016	551-5323	Grit Guard®
320-2114	315-1508	392-9096	595	555-5072	551-5412	Grit Guard® ¹
			598	555-5071	551-5412	
320-2115	310-1107	392-9066	592A/594A	555-5076	551-5356	Van Hool Bus Appl ¹
320-2118	315-1510	372-7095	665A	555-5069	551-5321	Grit Guard®
320-2129	315-1511	392-9094	580 or 582	555-5072	551-5393	Grit Guard®
320-2131	315-1508	392-9092	598	555-5071	551-5363	Grit Guard®
320-2136	310-1064	372-7049	JM511946	555-5055	551-5381	
320-2137		382-8064	6461A	555-5007	551-5327	Replaced by 383-0164
			681A	555-5071	551-5333	See Set Remarks
320-2162	315-1502	392-9087	683	555-5076	551-5333	Grit Guard®
320-2164	310-1037	382-8066	JM207049	555-5088	551-5366	
320-2173	315-1503	372-7091	749 or 749S	555-5024	551-5401	Grit Guard®
320-2213	315-1515	392-9112	663 or HM516449, -C	555-5072	551-5364	Grit Guard®
		392-9130	HM516449A	555-5073		

¹ Oil seal installs in bearing cup bore.

QUICK REFERENCE

P/N	FORMER P/N	INDUSTRY DESCRIPTION
HM212049	A212049	KHM212049, BEARING CONE
HM218248	A218248	KHM218248, BEARING CONE
HM518445	A518445	KHM518445, BEARING CONE
STMSET401	ASET580-72	K580/K572 BEARING SET
STMSET403	ASET594A-92A	K594A/K592A BEARING SET
STMSET406	ASET3782-20	K3782/K3720 BEARING SET
STMSET413	ASET049-011	KHM212049/KHM212011 BEARING SET
STMSET414	ASET248-210	KHM218248/KHM218210 BEARING SET
STMSET415	ASET445-410	HM518445/KHM518410 BEARING SET
STMSET423	ASET6461A-20	K6461A/K6420 BEARING SET
STMSET424	ASET555S-52A	K555S/K552A BEARING SET

	AXLE APPLICATIONS	OUTER BEARING CONE / CUP	MATCHED BEARING SET	INNER BEARING CONE / CUP	MATCHED BEARING SET
TRAILER AXLES	Meritor TP Series	HM518445 / HM518410	STMSET415	HM518445 / HM518410	STMSET415
	Meritor TN Series	HM212049 / HM212011	STMSET413	HM218248 / HM218210	STMSET414
STEER AXLES	Meritor FF Series	3782 / 3720	STMSET406	HM212049 / HM212011	STMSET413
	Meritor FL Series	552A / 555S	STMSET424	641A / 6420	STMSET423
DRIVE AXLES	Meritor R Series	580 / 572	STMSET401	594A / 592A	STMSET403

BEARINGS TO HUB SEAL SET CROSS REFERENCE

BEARINGS TO HUB SEAL SET CROSS REFERENCE

QUICK REFERENCE

INNER CUP & CONE	OUTER CUP & CONE	GUARDIAN®/ GUARDIAN® HP SEAL NO.	GRIT GUARD®/ STANDARD SET	VOYAGER®/ DISCOVER® XR
553X/557A	3720/3782	308-0836	382-8036	383-0136 383-0436
572/580	563/567	309-0903	392-9094	393-0103
572/582	563/567	309-0903	392-9094	393-0103
592A/593	65320/65390		372-7022 372-7062	
592A/594	572/580	309-0973	392-9131	393-0173 393-0473
592A/594A	572/580		392-9132	
592A/594A	572/582	309-0973	392-9131	393-0173 393-0473
592A/594A	572/582		392-9132	
592A/595	572/580		392-9096	
592A/598	572/575	309-0973	392-9131	393-0173 393-0473
592A/598A	653/665		392-9092	
592A/598	752/758		392-9092	
592A/598	HM617010/ HM617049		392-9092	
592A/598A	572/580		392-9132	
592A/598A	572/582	309-0973	392-9131	393-0173 393-0473
592A/598A	572/582		392-9132	
592A/598	HM617010/ HM617049		392-9132	
632/641	28622/28682			383-0156
633/641	65320/65385			383-8139
652/663	572/575	309-0904	392-9112	393-0104
653/663	553X560	307-0713	372-7098	373-0113
653/663	HM212011/ HM212049	307-0713	372-7098	373-0113
653/665A	HM212011/ HM212049	307-0744	372-7095	
672/681A	572/575		392-9087	
672/683	572/580		392-9087	
672/683XA	572/580		392-9087	

INNER CUP & CONE	OUTER CUP & CONE	GUARDIAN®/ GUARDIAN® HP SEAL NO.	GRIT GUARD®/ STANDARD SET	VOYAGER®/ DISCOVER® XR
672/687	772/780	309-0948	392-9089	393-0148
672/687	52618/52400	309-0948	392-9089	393-0148
742/749	632/643		372-7091 372-7024	
742/749S	632/643		372-7091 372-7024	
752/758	663/665		392-9001	
752/759	742/740		372-7015	
752/760	742/749		392-9001	
772/780	772/776	309-0948	392-9089	393-0148
772/780	854/864	309-0948	392-9089	393-0148
772/780	52618/52400	309-0948	392-9089	393-0148
772/780	77675/77375	309-0948	392-9089	393-0148
772/782	742/749		392-9053	
832/843	632/636		382-8008	
5735/5760	572/575	309-0912		393-0112
6320/6379	552A/557S			383-0101
6320/6386	552A/557S			383-0101
6320/6386A	532A/537			
6320/6389	552A/557S			383-0101
6420/6461A	552A/555S	308-0864	382-8064	383-0164 383-0464
6420/6461A	3920/3979	308-0864	382-8064	383-0164 383-0464
6535/6559	653/663			393-0134
6535/6580	653/663			393-0134
33462/33281	3920/3982	309-0935		
33462/33281	39520/39585		392-9036	
33462/33287	3920/3982	309-0935		
33821/33895	3120/3196		382-8016	
39520/39581	3525/3585	308-0836	382-8036	383-0136 383-0436
		308-0863		
45220/45284	25820/25880	308-0863		
47620/47678	39520/39585	309-0912	392-9099	393-0112
47620/47685	39520/39590	309-0912	392-9099	393-0112

INNER CUP & CONE	OUTER CUP & CONE	GUARDIAN®/ GUARDIAN® HP SEAL NO.	GRIT GUARD®/ STANDARD SET	VOYAGER®/ DISCOVER® XR
47620/47686	39520/39590	309-0912	392-9099	393-0112
				393-0112
H715311/ H715345	552A/555S			383-0156
H715311/ H715345	3920/3979	308-0853		
HM212010/ HM212049	28622/28682	308-0853		
HM212011/ HM212044	3720/3782	308-0836	382-8036	383-0136 383-0436
HM212011/ HM212047	3720/3782	308-0836	382-8036	383-0136 383-0436
HM212011/ HM212047	45220/ 45282			383-0171
HM212011/ HM212049	3720/3782	308-0836	382-8036	383-0136 383-0436
HM212011/ HM212049	45220/45280			383-0139
HM212011/ HM212049X	3720/3782	308-0836	382-8036	383-0136 383-0436
HM218210/ HM218248	HM212011/ HM212049	307-0743	372-7097	373-0143 373-0443
JM205110/ JM205149	25820/25877	308-0866	382-8066	383-0166
JM207010/ JM207049	25820/25877	308-0866	382-8066	383-0166
HM516410/ HM516449	47620/47679	309-0904	392-9112	393-0104
HM516410/ HM516449A	47620/47679	309-0904	392-9130	393-0104
HM518410/ HM518445	HM518410/ HM518445	307-0723	372-7099	373-0123 373-0423
JM205110/ JM204149A	25820/25877		382-8066	383-0166
JM511910/ JM510946	JM205110/ JM205149		372-7049	
JF7049A		308-0870		

QUICK REFERENCE

WHEN IT COMES TO WHEEL ENDS, WE HAVE YOU COVERED

STEMCO has provided the trucking industry with reliable hub seals for more than 70 years. Throughout our history, we have recognized the need for tougher, longer life seals that meet the performance, design and price requirements related to selecting the right seal for any fleet. To meet that need, STEMCO has engineered a menu of sealing options designed to meet the varying performance expectations of each fleet, all in an effort to maximize performance and value.

SELECTING THE RIGHT STEMCO SEAL FOR THE RIGHT APPLICATION.



DISCOVER® XR IS DESIGNED FOR THE LONG HAUL CARRIER seeking high performance components. The Discover® XR seal is an excellent choice for fleets running outboard-mounted drums that allow brake changes without seal replacement. The long life characteristics of this seal, proven in testing that exceeds competitive products' performance by five times, make it the industry choice for performance driven fleet managers.



THE VOYAGER® SEAL IS DESIGNED FOR REGIONAL ROUTE TRUCKS, city delivery and coach applications. Rugged design, simple installation and proven performance make Voyager the right choice for fleets looking for a superior brake job-to-brake job seal. In the everyday stop-and-go traffic environment these vehicles experience, the Voyager seal is the best value.



THE GUARDIAN® HP IS THE STANDARD SEAL for trailer and axle original equipment manufacturers. The axle installation is durable and unique, and has proven successful for more than 40 years. Today, its enhanced features offer improved cost-per-mile performance. With simple one-step axle installation, Guardian HP is the seal of choice in the trailer industry.



GRIT GUARD® IS ALWAYS ROUGH AND READY and has endured more than forty years of dirty, unfriendly road environments that destroy wheel end components. So with this sixty year plus track record of performance, Grit Guard endures where others fail, and is still the choice for fleets working in grueling environments.

GUARDIAN® & GUARDIAN® HP TRAILER AXLE HUB SEALS

GUARDIAN HP - TRAILER AXLE 307-0713	
BORE DIAMETER	5.700
INNER BEARING CUP/CONE	653/663
OUTER BEARING CUP/CONE	553X/560, HM212011/HM212049
SPINDLE SHOULDER O.D.	4.000
WIDTH	0.604
UNIV. AXLE TOOL HEAD	555-5100
INSTALLATION HANDLE/BODY	555-0001
GRIT GUARD® EQUIV.	372-7098
VOYAGER® EQUIV.	373-0113
DISCOVER® XR EQUIV.	

REMARKS: Do not use on early hubs and wheels that have seal bore diameter greater than 5.758".

RELATED PARTS	
HUB CAP W/ GASKET**	GASKET NUMBER**
340-4009	330-3009
340-4013	330-3013

GUARDIAN HP - TRAILER AXLE 307-0723	
BORE DIAMETER	6.008
INNER BEARING CUP/CONE	HM518410/HM518445
OUTER BEARING CUP/CONE	HM518410/HM518445
WIDTH	0.5629
UNIV. AXLE TOOL HEAD	555-5023
INSTALL HANDLE/BODY	555-0001
GRIT GUARD® EQUIV.	372-7099
VOYAGER® EQUIV.	373-0123
DISCOVER® XR EQUIV.	373-0423

REMARKS: Guardian® set for Pro-Par axle; Also Eaton P-22 and Meritor TP Hub Cap tool #570-7008.

RELATED PARTS	
HUB CAP W/ GASKET**	GASKET NUMBER**
340-4075	330-3077
340-4195	330-3118

GUARDIAN HP - TRAILER AXLE 307-0743	
BORE DIAMETER	6.000
INNER BEARING CUP/CONE	HM218210/HM218248
OUTER BEARING CUP/CONE	HM212011/HM212049
SPINDLE SHOULDER O.D.	4.625
WIDTH	0.584
UNIV. AXLE TOOL HEAD	555-5039
INSTALLATION HANDLE/BODY	555-0001
GRIT GUARD® EQUIV.	372-7097
VOYAGER® EQUIV.	373-0143
DISCOVER® XR EQUIV.	373-0443

REMARKS: Will not fit Std. Forge Hub mfg. prior to 8/71 nor Kershaw K-22 Axle prior to 1/73, nor Std. Forge A22-S Axle prior to 5/71, nor KBW prior to 1/78.

RELATED PARTS	
HUB CAP W/ GASKET**	GASKET NUMBER**
340-4009	330-3009
340-4013	330-3013

GUARDIAN HP - TRAILER AXLE 307-0744	
BORE DIAMETER	5.753
INNER BEARING CUP/CONE	653/665A
OUTER BEARING CUP/CONE	HM212011/HM212049
SPINDLE SHOULDER O.D.	4.625
WIDTH	0.584
UNIV. AXLE TOOL HEAD	555-5069
INSTALLATION HANDLE/BODY	555-0001
GRIT GUARD® EQUIV.	372-7095
VOYAGER® EQUIV.	373-0144

REMARKS: Do not use with Budd hubs having seal bore diameter greater than 5.758. When used with Eaton inboard skid control, use 320-2118.

RELATED PARTS	
HUB CAP W/ GASKET**	GASKET NUMBER**
340-4009	330-3009
340-4013	330-3013

SEAL SETS: TRAILER AXLES

Very Important. These seal sets must be installed with the tools listed in this catalog.

Hub caps sold separately.

NOTE: Use 555 series Tool Heads with Universal Axle Tool body 555-0001.

** For hub cap with pipe plug use 343-prefix.

VOYAGER® & DISCOVER® XR TRAILER AXLE HUB SEALS

VOYAGER & DISCOVER XR - TRAILER AXLE 373-0113

BORE DIAMETER	5.750
INNER BEARING CUP / CONE	653/663
OUTER BEARING CUP/CONE	553X/560, HM212011/HM212049
BEARING GUIDE	570-0023
SPINDLE SHOULDER O.D.	4.000
WIDTH	0.9399
FLEET HUB TOOL	551-5313
INSTALLATION HANDLE/BODY	551-0001
GUARDIAN® EQUIV.	307-0713
GRIT GUARD® EQUIV.	372-7098

REMARKS: Do not use on early hubs and wheels that have seal bore diameter greater than 5.758".

RELATED PARTS	
HUB CAP W/ GASKET**	GASKET NUMBER**
340-4009	330-3009
340-4013	330-3013

VOYAGER & DISCOVER XR - TRAILER AXLE 373-0123 373-0423

BORE DIAMETER	6.008
INNER BEARING CUP/CONE	HM518410/ HM518445
OUTER BEARING CUP/CONE	HM518410/ HM518445
BEARING GUIDE	570-0025
SPINDLE SHOULDER O.D.	4.250
WIDTH	0.995
FLEET HUB TOOL	551-5401
INSTALLATION HANDLE/BODY	551-0001
GUARDIAN® EQUIV.	307-0723
GRIT GUARD® EQUIV.	372-7099

REMARKS: Fits Pro-Par axle; also Eaton P-22 and Meritor TP. Hub cap tool #570-7008.

RELATED PARTS	
HUB CAP W/ GASKET**	GASKET NUMBER**
340-4075	330-3077
340-4195	330-3118

Very Important. These seal sets must be installed with the tools listed in this catalog.

Hub caps sold separately.

NOTE: Use 551 series tools with new Universal Hub Tool Handle 551-0001 (installs 320 series Voyager® and Discover® XR seals).

** For hub cap with pipe plug use 343-prefix.

VOYAGER & DISCOVER XR - TRAILER AXLE 373-0143 373-0443

BORE DIAMETER	6.000
INNER BEARING CUP/CONE	HM218210/HM218248
OUTER BEARING CUP/CONE	HM212011/HM212049
BEARING GUIDE	570-0026
SPINDLE SHOULDER O.D.	4.625
WIDTH	0.981
FLEET HUB TOOL	551-5412
INSTALLATION HANDLE/BODY	551-0001
GUARDIAN® EQUIV.	307-0743
GRIT GUARD® EQUIV.	372-7097

REMARKS: Will not fit Std. Forge Hub mfd.prior to 8/71 nor Kershaw K-22 Axle prior to 1/73, nor x prior to 1/73, nor Std. Forge A22-S KBW prior to 1/78.

RELATED PARTS	
HUB CAP W/ GASKET**	GASKET NUMBER**
340-4009	330-3009
340-4013	330-3013

VOYAGER - TRAILER AXLE 373-0144

BORE DIAMETER	5.753
INNER BEARING CUP/CONE	653/665A
OUTER BEARING CUP/CONE	HM212011/ HM212049
BEARING GUIDE	570-0024
SPINDLE SHOULDER O.D.	4.375
WIDTH	0.993
FLEET HUB TOOL	551-5339
INSTALLATION HANDLE/BODY	551-0001
GUARDIAN® EQUIV.	307-0744
GRIT GUARD® EQUIV.	372-7095

REMARKS: Do not use with Budd hubs having seal bore diameter greater than 5.758. When used with Eaton inboard skid control, use **320-2118**. Use Hub tool **551-5321** with **372-7095**

RELATED PARTS	
HUB CAP W/ GASKET**	GASKET NUMBER**
340-4009	330-3009
340-4013	330-3013

STANDARD TRAILER AXLE HUB SEALS

STANDARD - TRAILER AXLE 372-7015

BORE DIAMETER	6.437
OIL SEAL BORE DIAMETER	320-2041 6.437
INNER BEARING CUP/CONE	752/759
OUTER BEARING CUP/CONE	742/740
UNIVERSAL AXLE TOOL HEAD	555-5023
UNIVERSAL HUB TOOL HEAD	551-5398
INSTALLATION HANDLE/BODY	555-0001 & 551-0001
BEARING GUIDE	570-0025

REMARKS: N/A

RELATED PARTS	
HUB CAP W/ GASKET**	GASKET NUMBER**
340-4019	330-3019

STANDARD - TRAILER AXLE 372-7022

BORE DIAMETER	6.008
OIL SEAL BORE DIAMETER	320-2023 6.008
INNER BEARING CUP/CONE	592A/593
OUTER BEARING CUP/CONE	65320/65390
UNIVERSAL AXLE TOOL HEAD	NONE
UNIVERSAL HUB TOOL HEAD	551-5401
INSTALLATION HANDLE/BODY	555-0001 & 551-0001
BEARING GUIDE	570-0025

REMARKS: Fruehauf No. 5 (Prior to Feb. 1960) includes O-ring 355-5502

RELATED PARTS	
HUB CAP W/ GASKET**	GASKET NUMBER**
340-4019	330-3019

STANDARD - TRAILER AXLE 372-7049

BORE DIAMETER	4.500
OIL SEAL BORE DIAMETER	4.500
INNER BEARING CUP/CONE	JM511910/ JM511946
OUTER BEARING CUP/CONE	JM205110/ JM205149
UNIV. AXLE TOOL HEAD	555-5055
UNIV. HUB TOOL HEAD	551-5381
INSTALLATION HANDLE/BODY	555-0001 & 551-0001

REMARKS: N/A

RELATED PARTS	
HUB CAP W/ GASKET**	GASKET NUMBER**
340-4139*	330-3094

*Not available with pipe plug.

STANDARD - TRAILER AXLE 372-7062

BORE DIAMETER	6.008
OIL SEAL BORE DIAMETER	320-2023 6.008
INNER BEARING CUP/CONE	592A/593
OUTER BEARING CUP/CONE	65320/65390 HH506310/HH506348
UNIV. AXLE TOOL HEAD	555-5023
UNIV. HUB TOOL HEAD	551-5401
INSTALLATION HANDLE/BODY	555-0001 & 551-0001
BEARING GUIDE	570-0025

REMARKS: Fruehauf Modified #5, 2/60 & up.

RELATED PARTS	
HUB CAP W/ GASKET**	GASKET NUMBER**
340-4019	330-3019

Very Important. These seal sets must be installed with the tools listed in this catalog.

Hub caps sold separately.

* Not available with pipe plug.

** For hub cap with pipe plug use 343-prefix.

SEAL SETS: TRAILER AXLES

SEAL SETS: TRAILER AXLES

GRIT GUARD® TRAILER AXLE HUB SEALS

GRIT GUARD - TRAILER AXLE 372-7091

BORE DIAMETER	6.032
AXLE RING	315-1503
OIL SEAL BORE DIAMETER	320-2173 6.032
INNER BEARING CUP/CONE	742/749 or 749S
OUTER BEARING CUP/CONE	632/643
UNIVERSAL AXLE TOOL HEAD	555-5024
UNIVERSAL HUB TOOL HEAD	551-5401
INSTALLATION HANDLE/BODY	555-0001 & 551-0001
BEARING GUIDE	N/A

REMARKS: Will not fit S/F A-21-T prior to 6/71. Will not fit Gunite wheels R20-319 or T22-319.

RELATED PARTS	
HUB CAP W/ GASKET**	GASKET NUMBER**
	330-3011
	330-3104
	330-3056

GRIT GUARD - TRAILER AXLE 372-7095

BORE DIAMETER	5.753
AXLE RING	315-1510
OIL SEAL BORE DIAMETER	320-2118 5.753
INNER BEARING CUP/CONE	653/665A
OUTER BEARING CUP/CONE	HM212011/HM212049
UNIVERSAL AXLE TOOL HEAD	555-5069
UNIVERSAL HUB TOOL HEAD	551-5321
INSTALLATION HANDLE/BODY	555-0001 & 551-0001
BEARING GUIDE	570-0024

REMARKS: Do not use with Budd hubs having seal bore diameter greater than 5.758. When used with Eaton inboard skid control, use 320-2118.

RELATED PARTS	
HUB CAP W/ GASKET**	GASKET NUMBER**
340-4009	330-3009
340-4013	330-3013

GRIT GUARD - TRAILER AXLE 372-7096

BORE DIAMETER	7.135
AXLE RING	315-1506
OIL SEAL BORE DIAMETER	320-2111 7.135
INNER BEARING CUP/CONE	772/787
OUTER BEARING CUP/CONE	6535/6580
UNIVERSAL AXLE TOOL HEAD	555-5016
UNIVERSAL HUB TOOL HEAD	551-5323
INSTALLATION HANDLE/BODY	555-0001 & 551-0001
BEARING GUIDE	N/A

REMARKS: N/A

RELATED PARTS	
HUB CAP W/ GASKET**	GASKET NUMBER**
343-4107	330-3084

GRIT GUARD - TRAILER AXLE 372-7097

BORE DIAMETER	6.000
AXLE RING	315-1504
OIL SEAL BORE DIAMETER	320-2110 6.000
INNER BEARING CUP/CONE	HM218210/HM218248
OUTER BEARING CUP/CONE	HM212011/HM212049
UNIVERSAL AXLE TOOL HEAD	555-5039
UNIVERSAL HUB TOOL HEAD	551-5412
INSTALLATION HANDLE/BODY	555-0001 & 551-0001
BEARING GUIDE	570-0026

REMARKS: Will not fit:

- Std. Forge Hub mfg. prior to 8/71
- Kershaw K-22 axle prior to 1/73
- Std Forge A22-S axle prior to 5/71
- KBW prior to 1/78.

Ring 315-1504 will not fit shoulders less than .625.

RELATED PARTS	
HUB CAP W/ GASKET**	GASKET NUMBER**
340-4009	330-3009
340-4013	330-3013

GRIT GUARD - TRAILER AXLE 372-7098

AXLE RING	315-1507
OIL SEAL BORE DIAMETER	320-2109 5.750
INNER BEARING CUP/CONE	653/663
OUTER BEARING CUP/CONE	553X/560 HM212011/HM212049
UNIVERSAL AXLE TOOL HEAD	555-5100
UNIVERSAL HUB TOOL HEAD	551-5313
INSTALLATION HANDLE/BODY	555-0001 & 551-0001
BEARING GUIDE	570-0023

REMARKS: Do not use on early hubs and wheels that have seal bore diameter greater than 5.758".

RELATED PARTS	
HUB CAP W/ GASKET**	GASKET NUMBER**
340-4009	330-3009
340-4013	330-3013

GRIT GUARD - TRAILER AXLE 372-7099

AXLE RING	315-1503
OIL SEAL BORE DIAMETER	320-2023 6.008
INNER BEARING CUP/CONE	HM518410/HM518445
OUTER BEARING CUP/CONE	HM518410/HM518445
UNIVERSAL AXLE TOOL HEAD	555-5023
UNIVERSAL HUB TOOL HEAD	551-5401
INSTALLATION HANDLE/BODY	555-0001 & 551-0001
BEARING GUIDE	570-0025

REMARKS: Fits Pro-Par axle, Eaton P-22 and Meritor TP. Hub Cap Tool No. 570-7008

RELATED PARTS	
HUB CAP W/ GASKET**	GASKET NUMBER**
340-4075	330-3077
340-4195	330-3118

GUARDIAN® STEER AXLE HUB SEALS

GUARDIAN HP - FRONT AXLE 308-0836

BORE DIAMETER	4.840
BEARINGS AND TOOL COMBINATION:	
INNER BEARING CUP/CONE	39520/39581
OUTER BEARING CUP/CONE	3525/3585
TOOL HEAD	555-5062
BEARINGS AND TOOL COMBINATION:	
INNER BEARING CUP/CONE	HM212011/HM212044, 553X/557A
OUTER BEARING CUP/CONE	3720/3782
TOOL HEAD	555-5061

BEARINGS AND TOOL COMBINATION:	
INNER BEARING CUP/CONE	HM212011/ HM212049 HM212011/ HM212049- X, X1
OUTER BEARING CUP/CONE	3720/3782
TOOL HEAD	555-5098

BEARINGS AND TOOL COMBINATION:	
INNER BEARING CUP/CONE	HM212011/HM212047
OUTER BEARING CUP/CONE	3720/3782
TOOL HEAD	555-5066

SPINDLE SHOULDER O.D.	3.500
WIDTH	0.840
INSTALLATION HANDLE/BODY	555-0001
STANDARD SET EQUIV.	382-8036
VOYAGER® EQUIV.	383-0136
DISCOVER® XR EQUIV.	383-0436

REMARKS: Ford 9000# axle. Code N (FD-900),with 15x3 or 15x3-1/2 wedge brakes. GMC only (FE-900),prior to 1960 use, 320-2031. Be sure steering adjustment stop bolt does not interfere with ring.

RELATED PARTS	
HUB CAP W/ GASKET**	GASKET NUMBER**
340-4009	330-3009
340-4024	330-3024
340-4095	330-3009
340-4186	330-3120
340-4042	330-3041
340-4249	330-3122
340-4066	330-3041
340-4046	330-3009
340-4034	330-3034
340-4149	330-3097

GUARDIAN - FRONT AXLE 308-0853

BORE DIAMETER	5.372
BEARINGS AND TOOL COMBINATION:	
INNER BEARING CUP/CONE	632/641
OUTER BEARING CUP/CONE	3920/3979
TOOL HEAD	555-5060
BEARINGS AND TOOL COMBINATION:	
INNER BEARING CUP/CONE	H715311/H715345
OUTER BEARING CUP/CONE	3920/3979
TOOL HEAD	555-5070

BEARINGS AND TOOL COMBINATION:	
INNER BEARING CUP/CONE	HM212001/HM212049
OUTER BEARING CUP/CONE	28622/28682
TOOL HEAD	555-5060

WIDTH	0.518
INSTALL HANDLE/BODY	555-0001
STANDARD SET EQUIV.	
VOYAGER® EQUIV.	

RELATED PARTS	
HUB CAP W/ GASKET**	GASKET NUMBER**
340-4046	330-3009
340-4249	330-3122
340-4095	330-3009

GUARDIAN - FRONT AXLE 308-0855

BORE DIAMETER	5.875
INNER BEARING CUP/CONE	632/641
OUTER BEARING CUP/CONE	28622/28682
UNIVERSAL AXLE TOOL HEAD	555-5060
WIDTH	0.820
INSTALLATION HANDLE/BODY	555-0001
VOYAGER® EQUIV.	383-0156

REMARKS: Use with FA-109 1979 & up spoke wheel number 45493-C2. Must be used with hydraulic brakes after 75. FA-109 comes with hydraulic brakes. IHC application.

RELATED PARTS	
HUB CAP W/ GASKET**	GASKET NUMBER**
340-4249	330-3122

SEAL SETS: TRAILER AXLES

SEAL SETS: STEER AXLES

GUARDIAN® STEER AXLE HUB SEALS

VOYAGER® & DISCOVER® XR STEER AXLE HUB SEALS

SEAL SETS: STEER AXLES

SEAL SETS: STEER AXLES

GUARDIAN - FRONT AXLE 308-0863	
BORE DIAMETER	4.542
BEARINGS AND TOOL COMBINATION:	
INNER BEARING CUP/CONE	39520/39581
OUTER BEARING CUP/CONE	3525/3585
UNIVERSAL AXLE TOOL HEAD	555-5062
REMARKS: Ford 9000# 1975 to 1984	
BEARINGS AND TOOL COMBINATION:	
INNER BEARING CUP/CONE	45220/45284
OUTER BEARING CUP/CONE	25820/25880
UNIVERSAL AXLE TOOL HEAD	555-5064
REMARKS: Ford 9000# 1984 up	
SPINDLE SHOULDER O.D.	3.500
WIDTH	0.760
STANDARD SET EQUIV.	
INSTALLATION HANDLE/BODY	555-0001
RELATED PARTS	
HUB CAP W/ GASKET**	GASKET NUMBER**
340-4186	330-3120

GUARDIAN - FRONT AXLE 308-0864	
BORE DIAMETER	5.903
INNER BEARING CUP/CONE	6420/6461A
OUTER BEARING CUP/CONE	552A/555S, 3920/3979
UNIVERSAL AXLE TOOL HEAD	555-5007
SPINDLE SHOULDER O.D.	4.375
WIDTH	0.955
INSTALLATION HANDLE/BODY	555-0001
STANDARD SET EQUIV.	382-8064
VOYAGER® EQUIV.	383-0164
DISCOVER® XR EQUIV.	383-0464
RELATED PARTS	
HUB CAP W/ GASKET**	GASKET NUMBER**
340-4046	330-3009
340-4249	330-3122
343-4249	330-3122
340-4066	330-3041
340-4095	330-3009
340-4149	330-3097
340-4098	330-3009

GUARDIAN - FRONT AXLE 308-0866	
BORE DIAMETER	3.875
BEARINGS AND TOOL COMBINATION:	
INNER BEARING CUP/CONE	JM207010/JM207049A
OUTER BEARING CUP/CONE	25820/25877
TOOL HEAD	555-5088
BEARINGS AND TOOL COMBINATION:	
INNER BEARING CUP/CONE	JM205110/ JM205149A
OUTER BEARING CUP/CONE	25820/25877
TOOL HEAD	555-5089
WIDTH	0.495
INSTALLATION HANDLE/BODY	555-0001
STANDARD SET EQUIV.	382-8066
VOYAGER® EQUIV.	383-0166
RELATED PARTS	
HUB CAP W/ GASKET**	GASKET NUMBER**
340-4065	330-3040

Very Important. These seal sets must be installed with the tools listed in this catalog.

Hub caps sold separately.

NOTE: Use 555 series Tool Heads with Universal Axle Tool body 555-0001 (installs axle/deflector rings).

NOTE: Use 551 series tools with new Universal Hub Tool Handle 551-0001 (installs 320 series Voyager® and Discover® seals).

* Not available with pipe plug.

** For hub cap with pipe plug use 343-prefix.

VOYAGER - FRONT AXLE 383-0136 383-0436	
BORE DIAMETER	4.840
BEARINGS AND TOOL COMBINATION:	
INNER BEARING CUP/CONE	39520/39581
OUTER BEARING CUP/CONE	3525/3585
BEARING GUIDE	570-0017
BEARINGS AND TOOL COMBINATION:	
INNER BEARING CUP/CONE	HM212011/HM212044 553X/557A
OUTER BEARING CUP/CONE	3720/3782
BEARING GUIDE	570-0018
BEARINGS AND TOOL COMBINATION:	
INNER BEARING CUP/CONE	HM212011/ HM212049, HM212011/ HM212049X, X1
OUTER BEARING CUP/CONE	3720/3782
BEARING GUIDE	570-0020
BEARINGS AND TOOL COMBINATION:	
INNER BEARING CUP/CONE	HM212011/HM212047
OUTER BEARING CUP/CONE	3720/3782
BEARING GUIDE	570-0019
FLEET HUB TOOL	551-5346
SPINDLE SHOULDER O.D.	3.500
WIDTH	0.932
INSTALLATION HANDLE/BODY	551-0001
GUARDIAN® EQUIV.	308-0836
STANDARD SET EQUIV.	382-8036

REMARKS: Ford 9000# axle. Code N (FD-900), with 15x3 or 15x3-1/2 wedge brakes. GMC only (FE-900), prior to 1960, use **320-2031** sets. Be sure steering adjustment stop bolt does not interfere with ring.

RELATED PARTS	
HUB CAP W/ GASKET**	GASKET NUMBER**
340-4009	330-3009
340-4024	330-3024
340-4095	330-3009
340-4042	330-3041
340-4249	330-3122
340-4249	330-3122
340-4066	330-3041
340-4046	330-3009
340-4034	330-3034
340-4149	330-3097
343-4025	330-3025

VOYAGER - FRONT AXLE 383-0139	
BORE DIAMETER	5.120
BEARINGS AND TOOL COMBINATION:	
INNER BEARING CUP/CONE	632/641
OUTER BEARING CUP/CONE	65320/65385
FLEET HUB TOOL	551-5413
BEARING GUIDE	570-0020
BEARINGS AND TOOL COMBINATION:	
INNER BEARING CUP/CONE	HM212011/ HM212049
OUTER BEARING CUP/CONE	45220/45280
SPINDLE SHOULDER O.D.	4.000
WIDTH	0.968
INSTALLATION HANDLE/BODY	551-0001
STANDARD SET EQUIV.	

REMARKS: 383-0139 must be used with **310-1132** ring. Must be ordered as **383-8139** to receive **310-1132** ring.

RELATED PARTS	
HUB CAP W/ GASKET**	GASKET NUMBER**
343-4025	330-3025

Must be ordered as 383-8139 to receive 310-1132 ring

Very Important. These seal sets must be installed with the tools listed in this catalog.

Hub caps sold separately.

NOTE: Use 555 series Tool Heads with Universal Axle Tool body 555-0001 (installs axle/deflector rings).

NOTE: Use 551 series tools with new Universal Hub Tool Handle 551-0001 (installs 320 series Voyager® and Discover® XR seals).

* Not available with pipe plug.

** For hub cap with pipe plug use 343-prefix.

VOYAGER® & DISCOVER® XR STEER AXLE HUB SEALS

SEAL SETS: STEER AXLES

VOYAGER - FRONT AXLE 383-0156	
BORE DIAMETER	5.875
INNER BEARING CUP/CONE	H715311/H715345, 632/641
OUTER BEARING CUP/CONE	552A/555S, 28622/28682
BEARING GUIDE	570-0021
SPINDLE SHOULDER O.D.	4.500
WIDTH	0.988
FLEET HUB TOOL	551-5344
INSTALLATION HANDLE/BODY	551-0001
GUARDIAN® EQUIV.	
STANDARD SET EQUIV.	

REMARKS: Use 308-0855 for FA109 1979 & up Spoke wheel number 454593-C2. 308-0855 must be used with hydraulic brakes after '75. FA-109 comes with hydraulic brakes.

RELATED PARTS	
HUB CAP W/ GASKET**	GASKET NUMBER**
340-4046	330-3009
340-4249	330-3122
340-4095	330-3009

VOYAGER - FRONT AXLE 383-0164 383-0464	
BORE DIAMETER	5.903
INNER BEARING CUP/CONE	6420/6461A
OUTER BEARING CUP/CONE	552A/555S, 3979/3920
FLEET HUB TOOL	551-5327
BEARING GUIDE	570-0022
SPINDLE SHOULDER O.D.	4.375
WIDTH	1.03
INSTALLATION HANDLE/BODY	551-0001
GUARDIAN® EQUIV.	308-0864
STANDARD SET EQUIV.	382-8064

REMARKS: Mack

RELATED PARTS	
HUB CAP W/ GASKET**	GASKET NUMBER**
340-4249	330-3122
340-4046	330-3042
343-4249	330-3122
340-4066	330-3041
340-4095	330-3009
340-4149	330-3097
340-4098	330-3009

VOYAGER - FRONT AXLE 383-0166	
BORE DIAMETER	3.875
BEARINGS AND TOOL COMBINATION:	
INNER BEARING CUP/CONE	JM207010/JM207049A
OUTER BEARING CUP/CONE	25820/25877
BEARING GUIDE	570-0036
BEARINGS AND TOOL COMBINATION:	
INNER BEARING CUP/CONE	JM205110/JM205149A
OUTER BEARING CUP/CONE	25820/25877
BEARING GUIDE	570-0033
SPINDLE SHOULDER O.D.	2.875
WIDTH	0.750
FLEET HUB TOOL	551-5423
INSTALLATION HANDLE/BODY	551-0001
GUARDIAN® EQUIV.	308-0866
STANDARD SET EQUIV.	

REMARKS: Use Hub tool 551-5366 with 382-8066

RELATED PARTS	
HUB CAP W/ GASKET**	GASKET NUMBER**
340-4065	330-3040

STANDARD STEER AXLE HUB SEALS

SEAL SETS: STEER AXLES

STANDARD - STEER AXLE 382-8036	
AXLE RING	
OIL SEAL BORE DIAMETER	4.840
BEARINGS AND TOOL COMBINATION:	
INNER BEARING CUP/CONE	39520/39581
OUTER BEARING CUP/CONE	3525/3585
UNIV. AXLE TOOL HEAD	555-5062
BEARING GUIDE	570-0017

RELATED PARTS	
HUB CAP W/ GASKET**	GASKET NUMBER**
340-4249	330-3122
340-4046	330-3009
343-4249	330-3122
340-4066	330-3041
340-4095	330-3009
340-4149	330-3097
340-4098	330-3009

RELATED PARTS	
HUB CAP W/ GASKET**	GASKET NUMBER**
340-4009	330-3009
340-4024	330-3024
340-4095	330-3009
340-4042	330-3041
340-4249	330-3122
340-4066	330-3041
340-4034	330-3034
340-4149	330-3097

RELATED PARTS	
HUB CAP W/ GASKET**	GASKET NUMBER**
340-4009	330-3009
340-4024	330-3024
340-4095	330-3009
340-4042	330-3041
340-4249	330-3122
340-4066	330-3041
340-4034	330-3034
340-4149	330-3097

RELATED PARTS	
HUB CAP W/ GASKET**	GASKET NUMBER**
340-4009	330-3009
340-4024	330-3024
340-4095	330-3009
340-4042	330-3041
340-4249	330-3122
340-4066	330-3041
340-4034	330-3034
340-4149	330-3097

REMARKS: 9000# axle, 15x3 or 15x3.5 wedge brakes set. GMC only (FE-900), prior to 1960, use 320-2031.

RELATED PARTS	
HUB CAP W/ GASKET**	GASKET NUMBER**
340-4009	330-3009
340-4024	330-3024
340-4095	330-3009
340-4042	330-3041
340-4249	330-3122
340-4066	330-3041
340-4034	330-3034
340-4149	330-3097

STANDARD - STEER AXLE 382-8064	
INNER BEARING CUP/CONE	6420/6461A
OUTER BEARING CUP/CONE	552A/555S, 3979/3920
UNIV. AXLE TOOL HEAD	555-5007
FLEET HUB TOOL	551-5327
INSTALLATION HANDLE/BODY	555-0001 & 551-0001
BEARING GUIDE	570-0022

REMARKS: Mack

RELATED PARTS	
HUB CAP W/ GASKET**	GASKET NUMBER**
340-4249	330-3122
340-4046	330-3009
343-4249	330-3122
340-4066	330-3041
340-4095	330-3009
340-4149	330-3097
340-4098	330-3009

RELATED PARTS	
HUB CAP W/ GASKET**	GASKET NUMBER**
340-4065	330-3040

RELATED PARTS	
HUB CAP W/ GASKET**	GASKET NUMBER**
340-4009	330-3009
340-4024	330-3024
340-4095	330-3009
340-4042	330-3041
340-4249	330-3122
340-4066	330-3041
340-4034	330-3034
340-4149	330-3097

RELATED PARTS	
HUB CAP W/ GASKET**	GASKET NUMBER**
340-4009	330-3009
340-4024	330-3024
340-4095	330-3009
340-4042	330-3041
340-4249	330-3122
340-4066	330-3041
340-4034	330-3034
340-4149	330-3097

REMARKS: 9000# axle, 15x3 or 15x3.5 wedge brakes set. GMC only (FE-900), prior to 1960, use 320-2031.

RELATED PARTS	
HUB CAP W/ GASKET**	GASKET NUMBER**
340-4009	330-3009
340-4024	330-3024
340-4095	330-3009
340-4042	330-3041
340-4249	330-3122
340-4066	330-3041
340-4034	330-3034
340-4149	330-3097

STANDARD - STEER AXLE 382-8066	
OIL SEAL BORE DIAMETER	320-2164 3.875
BEARINGS AND TOOL COMBINATION:	
INNER BEARING CUP/CONE	JM207010/JM207049A
OUTER BEARING CUP/CONE	25820/25877
UNIV. AXLE TOOL HEAD	555-5088
FLEET HUB TOOL	551-5366
BEARING GUIDE	570-0036

RELATED PARTS	
HUB CAP W/ GASKET**	GASKET NUMBER**
340-4065	330-3040

RELATED PARTS	
HUB CAP W/ GASKET**	GASKET NUMBER**
340-4065	330-3040

REMARKS: N/A

RELATED PARTS	
HUB CAP W/ GASKET**	GASKET NUMBER**
340-4065	330-3040

NOTE: Use 555 series Tool Heads with Universal Axle Tool body 555-0001 (installs axle/deflector rings).
NOTE: Use 551 series tools with new Universal Hub Tool Handle 551-0001 (installs 320 series Voyager® and Discover® XR seals).
 * Not available with pipe plug.
 ** For hub cap with pipe plug use 343-prefix.

GUARDIAN® & GUARDIAN® HP DRIVE AXLE HUB SEALS

GUARDIAN® & GUARDIAN® HP DRIVE AXLE HUB SEALS

SEAL SETS: STEER AXLES

SEAL SETS: DRIVE AXLES

GUARDIAN HP - DRIVE AXLE 309-0903	
BORE DIAMETER	5.750
INNER BEARING CUP/CONE	572/580, 572/582
OUTER BEARING CUP/CONE	563/567
SPINDLE SHOULDER O.D.	4.5
WIDTH	0.516
UNIVERSAL AXLE TOOL HEAD	555-5072
INSTALLATION HANDLE/BODY	555-0001
GRIT GUARD® EQUIV.	392-9094
VOYAGER® EQUIV.	393-0103

REMARKS: Mack Western 11QJA-191, -192 hub and drum assembly, or Motor Wheel 87125 hub or 87119-B or 87226-F hub and drum assembly with 582 inner cone must use OEM bearing spacer 35AX-1411.

Install OEM spacer before installing axle ring. Press axle on until flush with bearing side of bearing spacer.

GUARDIAN - DRIVE AXLE 309-0904	
BORE DIAMETER	6.250
BEARINGS AND TOOL COMBINATION:	
INNER BEARING CUP/CONE	652/663 HM516410/ HM516449,-C
OUTER BEARING CUP/CONE	572/575 47620/47679
UNIV. AXLE TOOL HEAD	555-5072
GRIT GUARD® EQUIV.	392-9112
BEARINGS AND TOOL COMBINATION:	
INNER BEARING CUP/CONE	HM516410/HM516449A
OUTER BEARING CUP/CONE	47620/47679
UNIV. AXLE TOOL HEAD	555-5073
GRIT GUARD® EQUIV.	392-9130

SPINDLE SHOULDER O.D.	4.25
WIDTH	0.548
INSTALLATION HANDLE/BODY	555-0001
VOYAGER® EQUIV.	393-0104

REMARKS: Use OEM bearing spacer 35AX790 or 35AX1411. Use Grit Guard set **392-9130** with inner bearing HM516449A. Use **309-0904** only with ABS Brakes. Ref.: Tech Tip 15.

GUARDIAN - DRIVE AXLE 309-0912	
BORE DIAMETER	5.690
BEARINGS AND TOOL COMBINATION:	
INNER BEARING CUP/CONE	47620/47685 47620/47686
OUTER BEARING CUP/CONE	39520/39590
UNIV. AXLE TOOL HEAD	555-5031
BEARINGS AND TOOL COMBINATION:	
INNER BEARING CUP/CONE	47620/47678 5735/5760
OUTER BEARING CUP/CONE	39520/39590 572/575
UNIV. AXLE TOOL HEAD	555-5074

SPINDLE SHOULDER O.D.	3.875
WIDTH	0.555
INSTALLATION HANDLE/BODY	555-0001
GRIT GUARD® EQUIV.	392-9099
VOYAGER® EQUIV.	393-0112

REMARKS: Do not use OEM oil seal spacer ring. Use with 5.687" bore only. Will not replace **320-2102** on GMC-Chev. For Navistar w/ 39585 outer cone, use **392-9099**.

GUARDIAN - DRIVE AXLE 309-0935	
BORE DIAMETER	4.750
BEARINGS AND TOOL COMBINATION:	
INNER BEARING CUP/CONE	33462/33287 1962 UP
OUTER BEARING CUP/CONE	3920/3982
UNIV. AXLE TOOL HEAD	555-5011
BEARINGS AND TOOL COMBINATION:	
INNER BEARING CUP/CONE	33462/33281 thru 1961
OUTER BEARING CUP/CONE	3929/3982
UNIV. AXLE TOOL HEAD	555-5002

SPINDLE SHOULDER O.D.	3.437
WIDTH	0.541
INSTALLATION HANDLE/BODY	555-0001

GUARDIAN HP - DRIVE AXLE 309-0973	
BORE DIAMETER	6.310
BEARINGS AND TOOL COMBINATION:	
INNER BEARING CUP/CONE	592A/598A
OUTER BEARING CUP/CONE	572/580
TOOL HEAD	555-5071
BEARINGS AND TOOL COMBINATION:	
INNER BEARING CUP/CONE	592A/598
OUTER BEARING CUP/CONE	572/575
UNIV. AXLE TOOL HEAD	555-5071

BEARINGS AND TOOL COMBINATION:	
INNER BEARING CUP/CONE	592A/594
OUTER BEARING CUP/CONE	572/580
UNIV. AXLE TOOL HEAD	555-5076

BEARINGS AND TOOL COMBINATION:	
INNER BEARING CUP/CONE	592A/594A
OUTER BEARING CUP/CONE	572/580
UNIV. AXLE TOOL HEAD	555-5076
SPINDLE SHOULDER O.D.	4.767
WIDTH	0.91
INSTALLATION HANDLE/BODY	555-0001
GRIT GUARD® EQUIV.	392-9131
VOYAGER® EQUIV.	393-0173
DISCOVER® XR EQUIV.	393-0473

REMARKS: Will not work on Freightliner with Wagner Anti-Skid or Motorola 22-14670-14 Electronic Speedometers. Use **320-2106**.

Special note for Dodge, Freightliner, Kenworth and Peterbilt using this set on Eaton axles w/ Meritor hubs or wheels: Eaton 18 series single or 38D tandem with 4.375 spindle shoulder require shoulder bushing to be installed before axle ring. Eaton 19 series single or 44D tandem with 4.500 spindle shoulder require shoulder bushing be to installed before axle ring. Shoulder bushings and axle rings must be installed flush with spindle shoulder face. Shoulder bushings are not part of set and must be ordered separately. If axle has factory installed shoulder bushing, leave it in place and reuse if not damaged. Shoulder bushings are not required on Eaton axles if shoulder is already machined to 4.767. For wheel ends using 681A to 4.767. X bearing refer to **392-9087** set. Hub cap **340-4119** and gasket **330-3090** available for tag and pusher use. OD 4.776, ID 4.369, Width .980 OD 4.767, ID 4.500, Width .950.

Very Important. These seal sets must be installed with the tools listed in this catalog.

NOTE: Use 555 series Tool Heads with Universal Axle Tool body 555-0001 (installs axle/deflector rings).

VOYAGER® & DISCOVER® XR DRIVE AXLE HUB SEALS

SEAL SETS: DRIVE AXLES

VOYAGER - DRIVE AXLE 393-0103	
BORE DIAMETER	5.750
INNER BEARING CUP/CONE	572/580, 572/582
OUTER BEARING CUP/CONE	563/567
SPINDLE SHOULDER O.D.	4.500
WIDTH	1.003
FLEET HUB TOOL	551-5415
INSTALLATION HANDLE/BODY	551-0001
BEARING GUIDE	570-0023
GUARDIAN® EQUIV.	309-0903
GRIT GUARD® EQUIV.	392-9094

REMARKS: Mack Western 11QJA- 191, -192 hub and drum assembly or motor wheel 87125 hub or 87119-B or 87226-F hub and drum assembly with 582 inner cone must use OEM bearing spacer 35AX-1411.

VOYAGER - DRIVE AXLE 393-0104	
BORE DIAMETER	6.250
INNER BEARING CUP/CONE	652/663, HM516410/HM516449,-C
OUTER BEARING CUP/CONE	572/575, 47620/47679
SPINDLE SHOULDER O.D.	4.250
WIDTH	1.290
FLEET HUB TOOL	551-5414
INSTALLATION HANDLE/BODY	551-0001
BEARING GUIDE	570-0023
GUARDIAN® EQUIV.	309-0904
GRIT GUARD® EQUIV.	392-9112

REMARKS: Mack application, use OEM bearing spacer, #35AX790 or 35AX1411. **NOTE:** For cast axle housing only. With HM516449A see 392-9130 set.

VOYAGER - DRIVE AXLE 393-0148	
BORE DIAMETER	7.375
INNER BEARING CUP/CONE	672/687, 772/780
OUTER BEARING CUP/CONE	772/780, 52618/52400, 772/776, 776575/77375, 854/864
SPINDLE SHOULDER O.D.	5.250
WIDTH	1.000
FLEET HUB TOOL	551-5400
INSTALLATION HANDLE/BODY	551-0001
BEARING GUIDE	570-0032
GUARDIAN® EQUIV.	309-0948
GRIT GUARD® EQUIV.	392-9089

REMARKS: None

VOYAGER - DRIVE AXLE 393-0112	
BORE DIAMETER	5.690
BEARINGS AND TOOL COMBINATION:	
INNER BEARING CUP/CONE	47620/47685
BEARINGS AND TOOL COMBINATION:	
INNER BEARING CUP/CONE	47620/47686, 47620/47678, 5735/5760
OUTER BEARING CUP/CONE	39520/39590, 39520/39585, 572/575
BEARING GUIDE	570-0023, 570-0022
SPINDLE SHOULDER O.D.	3.875
WIDTH	0.820
FLEET HUB TOOL	551-5416
INSTALLATION HANDLE/BODY	551-0001
GUARDIAN® EQUIV.	309-0912
GRIT GUARD® EQUIV.	392-9099

VOYAGER - DRIVE AXLE 393-0134	
BORE DIAMETER	6.000
BEARINGS AND TOOL COMBINATION:	
INNER BEARING CUP/CONE	6535/6580
OUTER BEARING CUP/CONE	653/663
BEARING GUIDE	570-0025
BEARINGS AND TOOL COMBINATION:	
INNER BEARING CUP/CONE	6535/6559
OUTER BEARING CUP/CONE	653/663
BEARING GUIDE	570-0023
SPINDLE SHOULDER O.D.	4.875
WIDTH	0.790
FLEET HUB TOOL	551-5421
INSTALLATION HANDLE/BODY	551-0001
GRIT GUARD® EQUIV.	392-9034

VOYAGER - DRIVE AXLE 393-0173 393-0473	
BORE DIAMETER	6.310
BEARINGS AND TOOL COMBINATION:	
INNER BEARING CUP/CONE	592A/598A
OUTER BEARING CUP/CONE	572/580
BEARING GUIDE	570-0027
BEARINGS AND TOOL COMBINATION:	
INNER BEARING CUP/CONE	592A/598
OUTER BEARING CUP/CONE	572/575
BEARING GUIDE	570-0027
BEARINGS AND TOOL COMBINATION:	
INNER BEARING CUP/CONE	592A/594
OUTER BEARING CUP/CONE	572/580
BEARING GUIDE	570-0028
BEARINGS AND TOOL COMBINATION:	
INNER BEARING CUP/CONE	592A/594A
OUTER BEARING CUP/CONE	572/580
BEARING GUIDE	570-0028
SPINDLE SHOULDER O.D.	4.767
WIDTH	1.1270
FLEET HUB TOOL	551-5320
INSTALLATION HANDLE/BODY	551-0001
GUARDIAN® EQUIV.	309-0973
GRIT GUARD® EQUIV.	392-9131

VOYAGER - DRIVE AXLE 393-0173 393-0473	
REMARKS: For Dodge, Freightliner, Kenworth and Peterbilt using this set on Eaton axles with Meritor hubs or wheels:	
Eaton 18 series single or 38D tandem with 4.375 spindle shoulder require shoulder bushing to be installed before axle ring.	
Eaton 19 series single or 44D tandem with 4.500 spindle shoulder require shoulder bushing to be installed before axle ring.	
Shoulder bushings and axle rings must be installed flush with spindle shoulder face.	
Shoulder bushings are not part of set and must be ordered separately. If axle has factory installed shoulder bushing, leave it in place and reuse if not damaged.	
Shoulder bushings are not required on Eaton axles if shoulder is already machined to 4.767.	
For wheel ends using 681A inner bearing refer, to 392-9087 set.	
Hub cap 340-4119 and gasket 330-3090 available for tag and pusher use.*	
OD 4.776, ID 4.369, Width .980	
OD 4.767, ID 4.500, Width .950.	

REMARKS: None

STANDARD DRIVE AXLE HUB SEALS

SEAL SETS: DRIVE AXLES

STANDARD - DRIVE AXLE 392-9036	
BEARINGS AND TOOL COMBINATION:	
INNER BEARING CUP/CONE	33462/33281
OUTER BEARING CUP/CONE	39520/39585
UNIV. AXLE TOOL HEAD	555-5002
BEARINGS AND TOOL COMBINATION:	
INNER BEARING CUP/CONE	33462/33287
UNIV. AXLE TOOL HEAD	555-5011
BEARINGS AND TOOL COMBINATION:	
FLEET HUB TOOL	551-5353
BEARING GUIDE	570-0021
INSTALL HANDLE/BODY	555-0001 & 551-0001

REMARKS: Oil Seal 320-2057 installs in bearing cup bore.

STANDARD - DRIVE AXLE 392-9053	
AXLE RING	310-1089
OIL SEAL BORE DIAMETER	320-2099, 7.250
INNER BEARING CUP/CONE	772/782
OUTER BEARING CUP/CONE	742/749
UNIVERSAL AXLE TOOL HEAD	555-5016
FLEET HUB TOOL	551-5317
INSTALLATION HANDLE/BODY	555-0001 & 551-0001

REMARKS: Replace worn seal with 320-2059 (component of 320-2099). Press oil seal into retainer so leather lip points toward oil side. Do not hammer on seal. National AR-23 ring must be removed.

Very Important. These seal sets must be installed with the tools listed in this catalog.

NOTE: Use 555 series Tool Heads with Universal Axle Tool body 555-0001 (installs axle/deflector rings).

GRIT GUARD® DRIVE AXLE HUB SEALS

SEAL SETS: DRIVE AXLES

GRIT GUARD - DRIVE AXLE 392-9087	
AXLE RING	315-1502
OIL SEAL BORE DIAMETER	320-2162 7.000
BEARINGS AND TOOL COMBINATION:	
INNER BEARING CUP/CONE	672-681A
OUTER BEARING CUP/CONE	572/575, 572/580
UNIV. AXLE TOOL HEAD	555-5071
BEARING GUIDE	570-0027
BEARINGS AND TOOL COMBINATION:	
INNER BEARING CUP/CONE	672/682, 672/683XA
OUTER BEARING CUP/CONE	572/580
UNIV. AXLE TOOL HEAD	555-5076
BEARING GUIDE	570-0028
FLEET HUB TOOL	551-5333
INSTALLATION HANDLE/BODY	555-0001 & 551-0001

REMARKS: Special note for all Meritor R-143 & White Western Star 44D prior to Sept. 1973. These axles have 4.500 spindle shoulder diameter and require shoulder bushings to be installed before axle ring. Shoulder bushing and axle rings must be installed flush with spindle shoulder face. Shoulder bushings are not part of set and must be ordered separately. If axle has factory installed shoulder bushing, leave it in place & reuse if not damaged.

GRIT GUARD - DRIVE AXLE 392-9089	
AXLE RING	315-1516
OIL SEAL BORE DIAMETER	320-2097 7.375
INNER BEARING CUP/CONE	372/687, 772/780
OUTER BEARING CUP/CONE	772/780, 52618/52400, 772/776, 77675/77375, 524/864
UNIVERSAL AXLE TOOL HEAD	555-5004
FLEET HUB TOOL	551-5400
INSTALLATION HANDLE/BODY	555-0001 & 551-0001
BEARING GUIDE	570-0032
REMARKS: Use OEM bearing spacer #37AX335. 320-2059 is a component of 320-2097 . Must replace with the 320-2097 seal. 392-9089 and 309-0948 will not fit S582 or S652 after June 1998. Only use 393-0148 on these axles after June 1998. Won't fit 58,000 Mack 2000/2001.	
RELATED PARTS	
GUARDIAN® HP WHEEL SEAL	309-0948
VOYAGER® WHEEL SEAL	393-0148

GRIT GUARD - DRIVE AXLE 392-9094	
AXLE RING	315-1511
OIL SEAL BORE DIAMETER	320-2129 5.750
INNER BEARING CUP/CONE	572/580 572/582
OUTER BEARING CUP/CONE	563/567
UNIVERSAL AXLE TOOL HEAD	555-5072
FLEET HUB TOOL	551-5393
INSTALLATION HANDLE/BODY	555-0001 & 551-0001
BEARING GUIDE	570-0023
REMARKS: Mack Western 11QJA- 191, -192 hub and drum assembly or motor wheel 87125 hub or 87119-B or 87226-F hub and drum assembly with 582 inner cone must use OEM bearing spacer 35AX-1411. Install OEM bearing spacer before installing axle ring. Press axle ring on until flush with bearing side of bearing spacer.	
RELATED PARTS	
GUARDIAN® HP WHEEL SEAL	309-0903
VOYAGER® WHEEL SEAL	309-0103

REMARKS: Mack Western 11QJA- 191, -192 hub and drum assembly or motor wheel 87125 hub or 87119-B or 87226-F hub and drum assembly with 582 inner cone must use OEM bearing spacer 35AX-1411. Install OEM bearing spacer before installing axle ring. Press axle ring on until flush with bearing side of bearing spacer.

GRIT GUARD - DRIVE AXLE 392-9096	
AXLE RING	315-1508
OIL SEAL BORE DIAMETER	320-2114 6.000
BEARINGS AND TOOL COMBINATION:	
INNER BEARING CUP/CONE	592A/595
OUTER BEARING CUP/CONE	572/580
UNIV. AXLE TOOL HEAD	555-5072
BEARING GUIDE	570-0023
BEARINGS AND TOOL COMBINATION:	
INNER BEARING CUP/CONE	592A/598
OUTER BEARING CUP/CONE	572/575
UNIV. AXLE TOOL HEAD	555-5071
BEARING GUIDE	570-0027
FLEET HUB TOOL	551-5412
INSTALL HANDLE/BODY	555-0001 & 551-0001
REMARKS: Oil seal 320-2114 installs in bearing cup bore. For use with Eaton 42D replace OEM bearing spacer with 357-5706 if damaged. Dimensions: OD 4.375, ID 4.150, width .688.	
RELATED PARTS	
GUARDIAN® HP WHEEL SEAL	309-0912
VOYAGER® HUB SEAL	393-0112

NOTE: Use 555 series Tool Heads with Universal Axle Tool body 555-0001 (installs axle/deflector rings).
NOTE: Use 551 series tools with new Universal Hub Tool Handle 551-0001 (installs 320 series Voyager® and Discover® XR seals).

GRIT GUARD® DRIVE AXLE HUB SEALS

SEAL SETS: DRIVE AXLES

GRIT GUARD - DRIVE AXLE 392-9099	
AXLE RING	315-1501
OIL SEAL BORE DIAMETER	320-2102 5.250
BEARINGS AND TOOL COMBINATION:	
INNER BEARING CUP/CONE	47620/47685, 47620/47686
OUTER BEARING CUP/CONE	39520/39590
UNIV. AXLE TOOL HEAD	555-5031
BEARING GUIDE	570-0023
BEARINGS AND TOOL COMBINATION:	
INNER BEARING CUP/CONE	47620/47678
OUTER BEARING CUP/CONE	39520/39585
UNIV. AXLE TOOL HEAD	555-5074
BEARING GUIDE	570-0022
FLEET HUB TOOL	551-5318
INSTALLATION HANDLE/BODY	555-0001 & 551-0001
REMARKS: Oil seal 320-2102 installs in bearing cup bore. Do not use OEM oil seal spacer ring. This set will not fit early axles with 5760 inner bearing cone.	
RELATED PARTS	
GUARDIAN® HP HUB SEAL	309-0912
VOYAGER® HUB SEAL	393-0112

REMARKS: Oil seal 320-2102 installs in bearing cup bore. Do not use OEM oil seal spacer ring. This set will not fit early axles with 5760 inner bearing cone.

GRIT GUARD - DRIVE AXLE 392-9112	
AXLE RING	315-1515
OIL SEAL BORE DIAMETER	320-2213 6.251
INNER BEARING CUP/CONE	652/663 HM516410/ HM516449,-C
OUTER BEARING CUP/CONE	572/575 47620/47679
BEARING GUIDE	570-0023
UNIVERSAL AXLE TOOL HEAD	555-5072
FLEET HUB TOOL	551-5364
INSTALLATION HANDLE/BODY	555-0001 & 551-0001
REMARKS: Mack application, use OEM bearing spacer #35AX790 or 35AX1411. For cast axle housing only. With HM516449A see 392-9130 . Only 309-0904 can be used with ABS Brakes.	
RELATED PARTS	
GUARDIAN® HP HUB SEAL	309-0904
VOYAGER® HUB SEAL	393-0104

NOTE: Use 555 series Tool Heads with Universal Axle Tool body 555-0001 (installs axle/deflector rings).
NOTE: Use 551 series tools with new Universal Hub Tool Handle 551-0001 (installs 320 series Voyager® and Discover® XR seals).

GRIT GUARD - DRIVE AXLE 392-9130	
OIL SEAL BORE DIAMETER	320-2213 6.251
INNER BEARING CUP/CONE	HM516410/ HM516449A
OUTER BEARING CUP/CONE	572/575 47620/47679
BEARING GUIDE	570-0023
UNIVERSAL AXLE TOOL HEAD	555-5073
FLEET HUB TOOL	551-5364
INSTALLATION HANDLE/BODY	555-0001 & 551-0001
REMARKS: Mack application, seal set for use with HM516449A only. Do not use bearing spacer. 309-0904 and 393-0104 can be used with ABS Brakes. Ref Tech Tip #015.	
RELATED PARTS	
GUARDIAN® HP HUB SEAL	309-0904
VOYAGER® HUB SEAL	393-0104

GRIT GUARD - DRIVE AXLE 392-9131	
AXLE RING	315-1525*
OIL SEAL BORE DIAMETER	320-2106 6.310
BEARINGS AND TOOL COMBINATION:	
INNER BEARING CUP/CONE	592A/598A
OUTER BEARING CUP/CONE	572/580
UNIV. AXLE TOOL HEAD	555-5071
BEARING GUIDE	570-0027
BEARINGS AND TOOL COMBINATION:	
INNER BEARING CUP/CONE	592A/598
OUTER BEARING CUP/CONE	572/575
UNIV. AXLE TOOL HEAD	555-5071
BEARING GUIDE	570-0027
BEARINGS AND TOOL COMBINATION:	
INNER BEARING CUP/CONE	592A/594
OUTER BEARING CUP/CONE	572/580
UNIV. AXLE TOOL HEAD	555-5076
BEARING GUIDE	570-0028
BEARINGS AND TOOL COMBINATION:	
INNER BEARING CUP/CONE	592A/594A
OUTER BEARING CUP/CONE	572-580
UNIV. AXLE TOOL HEAD	555-5076
BEARING GUIDE	570-0028
FLEET HUB TOOL	551-5320
INSTALLATION HANDLE/BODY	555-0001 & 551-0001
REMARKS: Special note for Dodge, Freightliner, Kenworth & Peterbilt using this set on Eaton axles with Meritor hubs or wheels: Eaton 18 series single or 38D tandem with 4.375 spindle shoulder require shoulder bushing to be installed before axle ring. Eaton 19 series single or 44D tandem with 4.500 spindle shoulder require shoulder bushing to be installed before axle ring. Shoulder bushings & axle rings must be installed flush with spindle shoulder face. Shoulder bushings are not part of set & must be ordered separately. If axle has factory installed shoulder bushing, leave it in place & reuse if not damaged. Shoulder bushings are not required on Eaton axles if shoulder is already machined to the diameter for the 315-1525 axle ring. For wheel ends using 681A inner bearing refer to 392-9087 set. Hub cap 340-4119 & gasket 330-3090 available for tag and pusher use. This set fits ABS Systems (Anti-lock Brake System). * Will not fit on Freightliner with Wagner Anti-Skid or Motorola 22-14670-14 Electronic Speedometers.	
RELATED PARTS	
GUARDIAN® HP WHEEL SEAL	309-0973
VOYAGER® WHEEL SEAL	393-0173
DISCOVER® XR WHEEL SEAL	393-0473

NOTE: Use 555 series Tool Heads with Universal Axle Tool body 555-0001 (installs axle/deflector rings).
NOTE: Use 551 series tools with new Universal Hub Tool Handle 551-0001 (installs 320 series Voyager® and Discover® XR seals).

GRIT GUARD® DEFLECTOR RING SPECIFICATIONS

CAUTION: Dimensions shown in this section are nominal and are for parts identification only. Not intended for ring/seal combination design purposes.

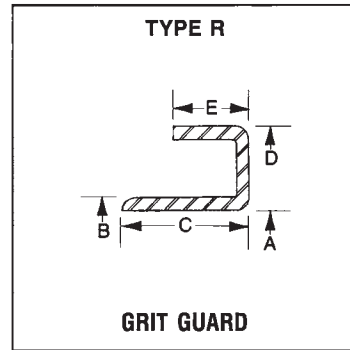

DEFLECTOR RING DIMENSIONS BY PART NUMBER

GRIT GUARD® DEFLECTOR RING	DEFLECTOR RING TYPE	A FOR SHOULDER O.D.	B SEAL AREA O.D.	C WIDTH	D FLANGE O.D.	E FLANGE WIDTH
315-1501	R	3.875	3.972	1.052	5.250	0.520
315-1502	R	4.767	4.854	1.008	6.147	0.630
315-1503	R	4.250	4.338	0.667	5.625	0.453
315-1504	R	4.625	4.730	0.730	5.875	0.430
315-1506	R	5.250	5.364	0.905	6.875	0.625
315-1507	R	4.000	4.127	0.603	5.625	0.365
315-1508	R	4.375	4.480	0.875	6.125	0.500
315-1509	R	4.262	4.375	0.811	5.630	0.468
315-1510	R	4.375	4.480	0.682	5.625	0.500
315-1511	R	4.500	4.597	0.950	5.685	0.437
315-1515	R	4.250	4.341	0.937	6.000	0.470
315-1516	R	5.250	5.375	1.110	7.125	0.395
315-1517	R	4.500	4.597	0.818	6.125	0.493
315-1519	R	4.250	4.341	1.187	6.000	0.470
315-1525	R	4.767	4.854	0.915	6.031	0.537
315-1530	R	4.767	4.872	0.915	5.935	0.400

DEFLECTOR RING DIMENSIONS BY SHOULDER O.D.

A FOR SHOULDER O.D.	DEFLECTOR RING TYPE	B SEAL AREA O.D.	C WIDTH	D FLANGE O.D.	E FLANGE WIDTH	GRIT GUARD® DEFLECTOR RING
3.875	R	3.972	1.052	5.250	0.520	315-1501
4.000	R	4.115	0.603	5.625	0.365	315-1507
4.250	R	4.341	1.187	6.000	0.470	315-1519
4.250	R	4.338	0.667	5.625	0.453	315-1503
4.250	R	4.369	0.937	6.000	0.470	315-1515
4.262	R	4.373	0.811	5.630	0.468	315-1509
4.375	R	4.480	0.682	5.625	0.500	315-1510
4.375	R	4.480	0.875	6.125	0.500	315-1508
4.500	R	4.597	0.950	5.685	0.437	315-1511
4.500	R	4.597	0.825	6.125	0.500	315-1517
4.625	R	4.730	0.745	5.875	0.490	315-1504
4.767	R	4.872	0.915	5.935	0.400	315-1530
4.767	R	4.854	1.008	6.147	0.630	315-1502
4.767	R	4.854	0.915	6.031	0.537	315-1525
5.250	R	5.375	1.110	7.125	0.395	315-1516
5.250	R	5.364	0.905	6.875	0.625	315-1506

OIL SEAL SPECIFICATIONS

CAUTION: Dimensions shown in this section are nominal and are for parts identification only. Not intended for ring/seal combination design purposes.

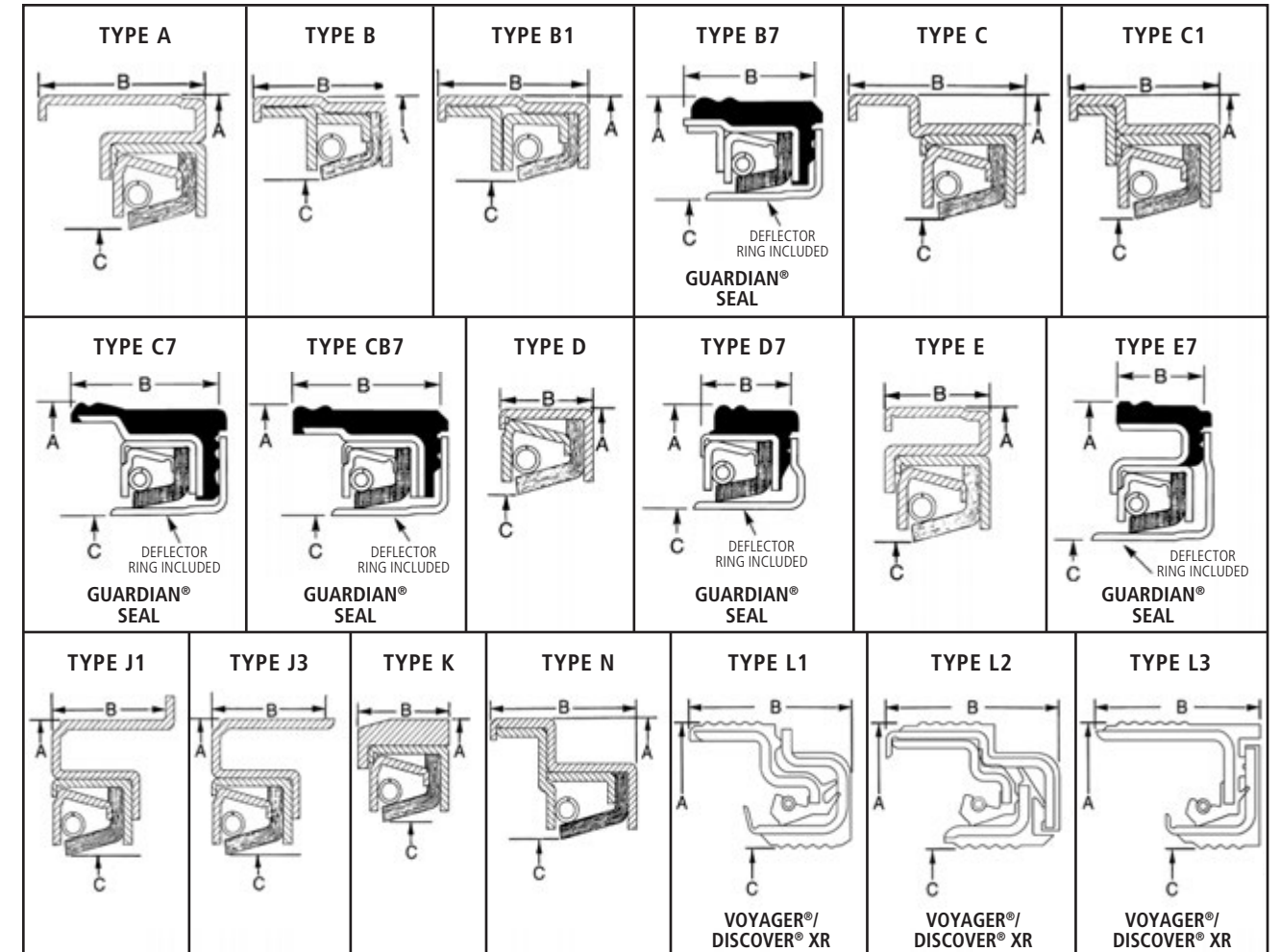

GUARDIAN®/GUARDIAN® HP HUB OIL SEAL DIMENSIONS BY PART NUMBER

GUARDIAN® SEAL NUMBER	TYPE	A FOR BORE DIAMETER	B WIDTH	C FOR SHOULDER O.D.	GUARDIAN® SEAL NUMBER	TYPE	A FOR BORE DIAMETER	B WIDTH	C FOR SHOULDER O.D.
307-0713 ²	E7	5.750	.604	4.000	308-0870	E7	5.512	.820	3.937
307-0723 ²	E7	6.008	.563	4.250	309-0903 ²	D7	5.750	.516	4.500
307-0743 ²	D7	6.000	.584	4.625	309-0904 ²	E7	6.250	.548	4.250
307-0744	C7	5.753	1.015	4.375	309-0912	E7	5.690	.555	3.875
308-0836 ²	CB7	4.840	.840	3.500	309-0935	D7	4.750	.541	3.437
308-0853	D7	5.372	.518	4.500	309-0948	E7	7.375	.735	5.250
308-0855 ¹	CB7	5.875	.820	4.500	309-0961	E7	6.064	.562	4.262
308-0863	B7	4.542	.760	3.500	309-0973 ²	C7	6.310	.910	4.767
308-0864 ²	E7	5.903	.955	4.375					
308-0866	D7	3.875	.495	2.875					

¹ Deflector ring width is .855.
² Guardian® HP.

OIL SEAL SPECIFICATIONS

OIL SEAL DIMENSIONS BY PART NUMBER

STEMCO SEAL NUMBER	TYPE	A FOR BORE DIAMETER	B WIDTH	C FOR AXLE RING O.D. +/- .010
320-2001	A	6.500	.906	4.955
320-2009	C	6.251	1.127	4.955
320-2018	B	4.125	.780	2.980
320-2023	N	6.008	.914	4.377
320-2031	A	5.000	.890	3.623
320-2039	B	5.125	.984	4.041
320-2041	A	6.437	.906	4.955
320-2059	D	6.250	.572	5.377
320-2061	C1	6.003	.895	4.955
320-2077	D	3.937	.473	3.125
320-2086	A	5.625	.600	4.127
320-2097	J3	7.375	.750	5.377
320-2099	K	7.250	.828	5.377
320-2102	B	5.250	1.043	3.972
320-2104	C1	5.500	1.000	4.041
320-2106	N	6.310	1.141	4.872

STEMCO SEAL NUMBER	TYPE	A FOR BORE DIAMETER	B WIDTH	C FOR AXLE RING O.D. +/- .010
320-2109	N	5.750	.866	4.127
320-2110	N	6.000	.818	4.733
320-2111	C1	7.135	1.093	5.377
320-2113	N	6.000	1.062	4.629
320-2114	N	6.000	1.062	4.481
320-2115	N	6.000	1.062	4.871
320-2118	N	5.753	.912	4.480
320-2129	N	5.750	.825	4.615
320-2131	N	6.250	1.023	4.485
320-2133	B1	4.542	.816	3.623
320-2162	C1	7.000	1.320	4.872
320-2164	B	3.875	.750	2.980
320-2173	N	6.032	.875	4.377
320-2181	B1	5.372	.937	4.600
320-2199	N	5.875	.903	4.600
320-2213	J1	6.251	.562	4.377

VOYAGER®/DISCOVER® XR OIL SEAL DIMENSIONS BY PART NUMBER

VOYAGER®/DISCOVER® XR SEAL NUMBER	TYPE	A FOR BORE DIAMETER	B WIDTH	C FOR SHOULDER O.D.
373-0113	L2	5.750	.940	4.000
373-0123	L1	6.008	.995	4.250
373-0143	L1	6.000	.981	4.625
373-0144	L3	5.753	.993	4.375
383-0101	L2	5.625	.625	4.000
383-0136	L1	4.840	.932	3.500
383-0139 ¹	L2	5.120	.968	4.000
383-0156	L2	5.875	.988	4.500
383-0164	L2	5.903	1.030	4.375
383-0166	L3	3.875	.750	2.875
383-0171	L2	5.000	.820	3.625
393-0103	L2	5.750	1.006	4.500

VOYAGER®/DISCOVER® XR SEAL NUMBER	TYPE	A FOR BORE DIAMETER	B WIDTH	C FOR SHOULDER O.D.
393-0104	L2	6.250	1.290	4.250
393-0112	L2	5.690	.820	3.875
393-0134	L2	6.000	.790	4.875
393-0148	L2	7.375	1.000	5.250
393-0173	L1	6.310	1.127	4.767
373-0423	L1	6.008	.995	4.250
373-0443	L1	6.000	.981	4.625
383-0436	L1	4.840	.932	3.500
383-0464	L2	5.903	1.030	4.375
393-0473	L2	6.310	1.127	4.767

¹ 383-0139 must be used with 310-1132 ring, available in Kit #383-8139.

OIL SEAL SPECIFICATIONS

GUARDIAN® HUB OIL SEAL DIMENSIONS BY BORE DIAMETER

A FOR BORE DIAMETER	GUARDIAN® TYPE	B WIDTH	C FOR SHOULDER O.D.	GUARDIAN® SEAL NUMBER
3.875	D7	.495	2.875	308-0866
4.542	B7	.760	3.500	308-0863
4.750	D7	.541	3.437	309-0935
4.840	CB7	.840	3.500	308-0836
5.372	D7	.518	4.500	308-0853
5.512	E7	.820	3.937	308-0870
5.690	E7	.555	3.875	309-0912
5.750	E7	.604	4.000	307-0713
5.750	D7	.516	4.500	309-0903
5.753	C7	1.015	4.375	307-0744

¹ Deflector ring width is .885.

OIL SEAL DIMENSIONS BY BORE DIAMETER

A FOR BORE DIAMETER	SEAL TYPE	B WIDTH	C FOR AXLE RING O.D. +/- .010	STEMCO OIL SEAL NUMBER
3.875	B	.750	2.980	320-2164
3.937	D	.473	3.125	320-2077
4.125	B	.780	2.980	320-2018
4.542	B1	.816	3.623	320-2133
5.000	A	.890	3.623	320-2031
5.250	B	1.043	3.972	320-2102
5.372	B1	.937	4.600	320-2181
5.500	C1	1.000	4.041	320-2104
5.750	N	.866	4.127	320-2109
5.750	N	.825	4.615	320-2129
5.753	N	.912	4.480	320-2118
5.875	N	.903	4.600	320-2199
6.000	B	1.062	4.481	320-2114
6.000	B	1.062	4.629	320-2113
6.000	N	.818	4.733	320-2110
6.000	B	1.062	4.871	320-2115

A FOR BORE DIAMETER	GUARDIAN® TYPE	B WIDTH	C FOR SHOULDER O.D.	GUARDIAN® SEAL NUMBER
5.875	CB7	.820	4.500	308-0855 ¹
5.903	E7	.955	4.375	308-0864
6.000	D7	.584	4.625	307-0743
6.008	E7	.563	4.250	307-0723
6.064	E7	.562	4.262	309-0961
6.250	E7	.548	4.250	309-0904
6.310	C7	.910	4.767	309-0973
7.375	E7	.735	5.250	309-0948

A FOR BORE DIAMETER	SEAL TYPE	B WIDTH	C FOR AXLE RING O.D. +/- .010	STEMCO OIL SEAL NUMBER
6.003	C1	.895	4.955	320-2061
6.008	N	.914	4.377	320-2023
6.032	N	.875	4.377	320-2173
6.250	N	1.023	4.485	320-2131
6.250	D	.572	5.377	320-2059
6.251	J1	.562	4.377	320-2213
6.251	C	1.127	4.955	320-2009
6.310	N	1.141	4.872	320-2106
6.437	A	.906	4.955	320-2041
6.500	A	.906	4.955	320-2001
7.000	C1	1.320	4.872	320-2162
7.135	C1	1.093	5.377	320-2111
7.250	K	.828	5.377	320-2099
7.375	J1	.750	5.377	320-2097

COMPONENT SPECIFICATIONS

COMPONENT SPECIFICATIONS

INNOVATIVE DESIGNS AND SUPERIOR MATERIALS ENSURE SAFETY AND DURABILITY

STEMCO® has provided the trucking industry with reliable hub caps for more than 60 years. Throughout our history, we have recognized the need for tougher, long-lasting hub caps that meet the performance, design and price requirements related to selecting the right hub cap for any fleet. To meet that need, STEMCO has engineered a menu of hub cap options designed to meet the varying performance expectations of each fleet, all in an effort to maximize performance and value.

With wheel end integrity and down time on the line, do not accept lesser quality imitations or knock offs. Trust the experts, trust STEMCO.

Innovative Product Line
Product- and application-specific technology designed to eliminate contaminants and extend wheel end life.

Superior Materials
Cast aluminum to dissipate heat.

Numerous Lubricant Options
Oil, semi-fluid grease, and hard-pack grease hub caps to meet performance, design and price requirements of today's fleets worldwide.

Broad Application Coverage
Full-line coverage for trailer and tractor applications.

WHEEL END

Traditional Hub Caps

The traditional aluminum series 340 and 343 provide durability with the trademark red plug to allow venting of the hub cap. Using cast aluminum for constructing the hub cap body prevents warpage and provides superior durability and heat-dissipation properties. The trucking industry recognizes STEMCO hub caps as the benchmark.



343-4024 Steer 343-4046 Steer 343-4065 Steer 343-4095 Steer 343-4249 Steer 346-5110 Steer
340-4119 Drive 340-4975 Trailer 343-4009 Trailer 343-4075 Trailer 343-4342 Trailer

Sentinel® Hub Caps

Sentinel Technology provides an unmatched filtering system to eliminate contamination of lubricant from grime, dirt or water. STEMCO provides four options to put Sentinel Technology to work for you:

- The Sentinel hub cap provides a tamper-proof system for maximum protection and maintenance-free performance.
- Integrated Sentinel hub caps integrate the Sentinel features into the window with fewer components and greater wheel end visibility.
- The Sentinel ESP (Extended Service Plug) and Sentinel ESP Filtered Drive Axle Vent allow economical retrofitting of wheel ends and drive axles with the benefits of STEMCO's exclusive Sentinel Technology.



359-6125 ESP Plus Plug (bulk pack of 50)
359-6124 ESP Plus Plug Blister Pack (2/pk)
359-6137 Drive Axle Vent

POPULAR REPLACEMENT PARTS

- **359-5995**
4009 Oil Window Kit
- **359-5990**
Large Red Rubber Plug
- **359-5915**
Small 3/4" Red Rubber Plug

Stamped Steel Hub Caps

STEMCO Stamped Steel grease hub caps are manufactured from 14-gauge steel and have a protective yellow chromate plating with a clear lacquer coating for additional protection from corrosion. For synthetic-base grease, use the vented 340-5096 version cap. For petroleum-base grease, use the non-vented 340-5097 cap.



340-0044 Steer 340-5096 Trailer 340-5097 Trailer 352-4009 Trailer 342-4009 Trailer

Grease Hub Caps

For grease applications, the 342 series Dirt Exclusion hub caps provide the same 340 casting without a side fill plug, plus a solid window with a sintered metal vent for venting purposes. To further support grease wheel ends, STEMCO developed the 352 series Solid Aluminum hub caps with a duckbill vent inserted in the face of a solid hub cap.

Inflation Hub Caps

STEMCO tire inflation hub caps are available in both oil and grease for several popular applications. The oil hub caps have a side fill plug and a standard window with oil fill lines. The grease hub caps do not have a side fill plug and incorporate a gray opaque window with no markings.



343-4370 PSI™

Defender™ Hub Caps

The Defender hub cap is 100% corrosion-free, with stainless steel reinforcement inserts. It achieves longer wheel-end life using a magnetic plug that pulls abrasive material away from critical components. An exception chemical bond between the hub cap and window ensures a strong seal and no leaks.



368-4195 Trailer 363-4009 Trailer 366-4024 Steer

Hubodometer® Hub Caps

STEMCO Hubodometer hub caps provide ease and convenience when installing our mechanical or electronic DataTrac® Hubodometers. The 347 series aluminum hub cap is mounted with a hubo window while the 640 series is a full grilamid Hubodometer hub cap with a metallic flange. Both allow for mounting of the Hubodometer directly through the center of the hub cap.



347-4009 Trailer 640-0001 Trailer

Popular Hub Cap Options With Bolt Specifications

STEMCO BASE PART NUMBER	STANDARD HUB CAP, NO SIDE FILL	DEFENDER™ HUB CAP	DIRT EXCLUSION, GREASE	STANDARD HUB CAP, SIDE FILL	DEFENDER™ HUB CAP	STANDARD HUB CAP, HUBO WINDOW	SENTINEL® HUB CAP	SENTINEL® HUB CAP GREASE	SOLID ALUMINUM GREASE / VENTED	INTEGRATED SENTINEL® OIL	DEFENDER™ HUB CAP	INTEGRATED SENTINEL® GREASE	DEFENDER™ HUB CAP	BOLT CIRCLE	BOLT SIZE	NUMBER OF BOLTS
	340	360	342	343	363	347	348	349	352	356	366	358	368			
4009	X	X	X	X	X	X	X	X	X	X	X	X	X	5-1/2	5/16	6
4013	X		X	X		X	X	X		X		X		5-1/2	5/16	5
4024	X	X	X	X	X					X	X	X		4-1/2	5/16	6
4046	X			X			X	X		X		X		5-1/2	5/16	6
4075	X		X	X		X	X	X		X		X		6-1/4 x 8 UN(M)		
4095	X		X	X			X	X	X	X		X		5-1/2	5/16	6
4195	X	X	X	X	X	X	X	X	X	X	X	X	X	6-3/4	5/16	6
4249	X		X	X										5-1/2	5/16	6
4281							X	X						5-17/32	3/8	6
4370*	X			X										5-1/2	5/16	6
4371*	X			X										6-1/4 x 8 UN(M)		
4372*	X			X										6-3/4	5/16	6

Legend

- 340/360 - No Pipe Plug
- 342 - Dirt Exclusion Grease
- 343/363 - With Pipe Plug
- 348 - Sentinel® Oil
- 349 - Sentinel® Grease
- 350 - With ESP Sentinel® Plug
- 353 - With ESP Sentinel® Plug
- 356/366 - Sentinel® Oil - Integrated
- 358/368 - Sentinel® Grease Integrated
- 349 - Sentinel® Grease
- 4009 - Tapered Spindle "TN"
- 4195 - Parallel Spindle "TP"

*PSI

HUB CAP CROSSOVER

COMPETITIVE PART NO.	COMPETITOR'S NAME	STEMCO PART NO.	COMPETITIVE PART NO.	COMPETITOR'S NAME	STEMCO PART NO.
1282	SKF	340-4975	340-009BK	National	300-4009
1612	SKF	343-4024	340-975	National	340-4975
1612	SKF	360-4024	340-975BK	National	340-4975
1612	SKF	363-4024	343-009	National	343-4009
1642	SKF	343-4013	343-009BK	National	303-4009
1643	SKF	343-4009	506085	Eaton	343-4024
1643	SKF	360-4009	506089	Eaton	343-4249
1643	SKF	363-4009	64009	TriSeal	343-4009
1643	SKF	366-4009	64009H	TriSeal	347-4009
1643	SKF	368-4009	64013	TriSeal	343-4013
1682	SKF	343-4075	64024	TriSeal	343-4024
1696	SKF	343-4195	64042	TriSeal	343-4024
1696	SKF	360-4195	64046	TriSeal	343-4046
1696	SKF	363-4195	64046	TriSeal	343-4095
1696	SKF	366-4195	64046	TriSeal	343-4249
1696	SKF	368-4195	64075A	TriSeal	343-4075
1703	SKF	343-4249	64075G	TriSeal	342-4075
1711	SKF	343-4024	64075P	SKF	340-4975
1742	SKF	343-4013	64249	SKF	343-4249
1743	SKF	343-4009	812928	SKF	343-4095
1743	SKF	343-4046	815214	SKF	343-4195
1743	SKF	343-4095	821338	SKF	343-4009
1753	SKF	343-4249	821907	SKF	343-4009
1788	SKF	343-4249	C40-4009	SKF	340-4009
1800	SKF	347-4009	C40-4009BP	SKF	300-4009
1811	SKF	343-4024	C40-4975	SKF	340-4975
1742	SKF	343-4013	C40-4975BP	SKF	340-4975
1843	SKF	343-4009	C40-5097BP	SKF	340-5097
1843	SKF	343-4046	C43-4009BP	SKF	303-4009
1843	SKF	343-4095	C43-4013	SKF	343-4013
1890	SKF	343-4249	C43-4024	SKF	343-4024
340-009	National	340-4009	C43-4075	SKF	343-4075

HUB CAP TORQUE SPECS

THREADED HUB CAPS		HUB CAP MOUNTING BOLTS			
XXX-4075	100 ft/lbs	1/4"	8-12 ft/lbs	5/8"	22-26 ft/lbs
340-4975	50-60 ft/lbs	5/16"	12-16 ft/lbs	3/4"	24-28 ft/lbs
340-4976	50-60 ft/lbs	3/8"	16-20 ft/lbs	7/8"	26-30 ft/lbs
640-0003	50-60 ft/lbs	7/16"	18-22 ft/lbs	6MM	8-12 ft/lbs
		1/2"	20-24 ft/lbs	8.5MM	12-16 ft/lbs

COMPETITIVE PART NO.	COMPETITOR'S NAME	STEMCO PART NO.
C43-4095	SKF	343-4095
C43-4098	SKF	343-4098
C43-4249	SKF	343-4249
DG-5/6P	Dual Dynamics	340-4013
DG-5/6PS	Dual Dynamics	343-4013
DG-6F	Dual Dynamics	340-4046
DG-6F4.5	Dual Dynamics	340-4024
DG-6F4.5P	Dual Dynamics	343-4013
DG-6F4.5PC	Dual Dynamics	343-4024
DG-6FL	Dual Dynamics	340-4249
DG-6FP	Dual Dynamics	347-4009
DG-6FPC	Dual Dynamics	340-4024
DG-6P	Dual Dynamics	340-4009
DG-6PS	Dual Dynamics	343-4009
DG-6PSC	Dual Dynamics	340-4046
DG-7.5P	Dual Dynamics	340-4195
DG-7.5PS	Dual Dynamics	343-4195
DG-P	Dual Dynamics	340-4075
DG-PS	Dual Dynamics	343-4075
DG-PSC	Dual Dynamics	343-4249
H075	National	343-4075
HU009A	National	343-4009
HU009A	National	343-4046
HU013A	National	343-4013
HU024A	National	343-4024
HU110A	National	343-4095
HU110A	National	343-4249

HUB CAP COMPONENTS		
359-6032	#8 Torx Screw	18-23 in/lbs
359-5984	3/8" Mag Plug	5-9 ft/lbs
359-5985	3/8" Pipe Plug	5-9 ft/lbs

HUB CAP SPECIFICATIONS

BOLT-ON HUB CAPS BY BOLT CIRCLE

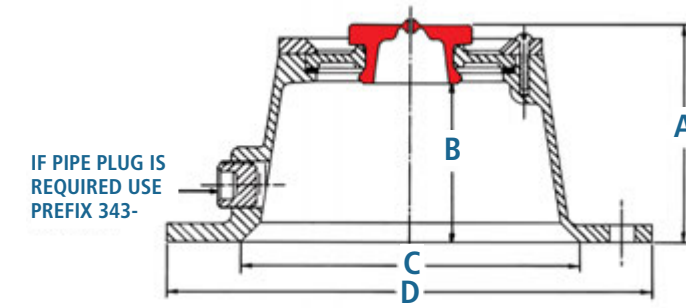

How to Determine Bolt Circle

Count the number of mounting holes; measure diameter of bolts; measure bolt circle (select 2 holes opposite each other and measure from the center of one bolt to the center of the one opposite). On odd number holes, measure inside diameter of hub and add twice the distance from the bore to the center of bolt hole.

BOLT CIRCLE	BOLT SIZE	NO. OF BOLTS	A HEIGHT	B INSIDE DEPTH	C FLANGE I.D.	D FLANGE O.D.	HUB CAP INCLUDES GASKET	GASKET NUMBER
3-5/8	5/16	4	2-1/4	1-1/2	2-1/2	4-1/2	340-4065	330-3040
4	1/4	4	2-1/8	1-3/8	3-1/8	4-9/16	340-4157 ¹	330-3102
4-1/16	3/16	6	2-5/8	1-7/8	3-5/16	4-1/2	340-4139 ¹	330-3094
4-1/2	5/16	6	2-5/8	1-7/8	3-1/2	5-1/4	340-4024	330-3024
4-1/2	5/16	6	2-5/8	1-7/8	3-1/2	5-1/4	343-4308	330-3024
4-1/2	6mm	6	2-5/8	1-7/8	3-1/2	5-1/4	340-4263	330-3024
5	5/16	4	2-1/8	1-3/8	4	5-3/4	340-4186	330-3120
5-1/8	5/16	6	2-7/8	2-1/8	3-3/4	5-3/4	340-4066	330-3041
5-1/8	5/16	6	1-7/8	1-1/8	4	5-11/16	340-4042	330-3041
5-1/4	3/8	3	2-7/8	2-1/8	4-3/8	6	340-4002	330-3002
5-1/4	3/8	3	3-1/2	2-3/4	4-1/8	Not Round	340-4019	330-3019
5-1/2	5/16	6	1-1/4	1-1/8	4-7/16	6-3/16	340-4098	330-3009
5-1/2	5/16	5	2-11/16	1-15/16	4-3/8	6-1/4	340-4013	330-3013
5-1/2	5/16	6	1-13/16	1-11/16	4-7/16	6-3/16	340-4249 ³	330-3122
5-1/2	5/16	6	1-13/16	1-1/16	4-9/16	6-3/16	340-4095	330-3009
5-1/2	5/16	6	2-5/16	1-9/16	4-9/16	6-3/16	340-4046	330-3009
5-1/2	5/16	6	2-11/16	1-15/16	4-3/8	6-1/4	340-4009	330-3009
5-1/2	5/16	6	2-11/16	1-15/16	4-3/8	6-1/4	343-4342	330-3009
5-9/16	5/16	6	2-7/8	2-1/8	3-11/16	6-3/8	340-4149	330-3097
6	5/16	6	2-1/2	1-3/4	4-15/16	6-7/8	343-4176	330-3060
6-5/8	1/4	6	2-13/16	2-1/16	5-5/16	7-1/8	340-4034	330-3034
6-3/4	5/16	6	3-11/16	2-15/16	5-7/16	7-1/2	340-4195	330-3118
7	5/8	8	2-1/16	1-5/16	4-5/16	8-1/4	340-4119 ¹	330-3090
7	13/16	8	2-1/16	1-5/16	4-5/16	8-1/4	340-4305 ¹	330-3090
7-1/4	1/4	6	2-7/8	2-1/8	6-1/4	7-7/8	343-4107 ²	330-3084

¹ Cannot be made with pipe plug
² Made with pipe plug only
³ Fits 5-1/2 and 5-9/16 bolt circles

HUB CAP SPECIFICATIONS

4009 HUB CAP VARIATIONS

APPLICATION	PART NUMBER	DESCRIPTION
Oil	343-4350	Cast aluminum hub cap with PSI face & side fill plug
Oil	347-4009	Cast aluminum hub cap with hubo window & side fill plug
Oil	348-4009	Cast aluminum hub cap with Sentinel® Technology and side fill plug
Oil	356-4009	Integrated Sentinel®
Grease/Oil	340-4009	Cast aluminum hub cap with large red fill plug & no side fill plug
Grease/Oil	343-4009	Cast aluminum hub cap with large red fill plug & side fill plug
Grease/Oil	300-4009	Cast aluminum hub cap with large red fill plug & no side fill plug in 50 unit bulk pack
Grease/Oil	303-4009	Cast aluminum hub cap with large red fill plug & side fill plug in 50 unit bulk pack
Grease	340-4350	Cast aluminum hub cap with PSI face & no side fill plug
Grease	340-5096	Stamped steel hub cap with vent
Grease	340-5097	Stamped steel hub cap with no vent
Grease	342-4009	Cast aluminum hub cap with dirt exclusion window & no side fill plug
Grease	347-4278	Cast aluminum hub cap with hubo window & no side fill plug
Grease	347-5096	Stamped steel hub cap with hubo mounting hole & vent
Grease	349-4009	Cast aluminum hub cap with Sentinel® Technology and no side fill plug
Grease	352-4009	Cast aluminum hub cap with solid top (duckbill vent) & no side fill plug
Grease	358-4009	Integrated Sentinel®

BULK HUB CAPS

STANDARD PART #	BULK PART #	BULK QTY.	GASKET #
340-4009	300-4009	25	330-3009 - Included
343-4009	303-4009	25	330-3009 - Included
340-5097	300-5097	25	330-3009 - Included
340-5096	300-5096	25	330-3009 - Included

TORQUE SPECIFICATIONS

HUB CAP MOUNTING BOLTS			
BOLT SIZE	TORQUE	BOLT SIZE	TORQUE
3/16	8-10 ft. lbs.	1/2	20-24 ft. lbs.
1/4	8-12 ft. lbs.	3/4	24-28 ft. lbs.
5/16	12-16 ft. lbs.	7/8	26-30 ft. lbs.
3/8	16-20 ft. lbs.	6 MM	8-12 ft. lbs.
7/16	18-22 ft. lbs.	8.5 MM	12-16 ft. lbs.

THREADED HUB CAPS	
PART #	TORQUE
XXX-4075	100 ft. lbs.
340-4975	50-60 ft. lbs.
340-4976	50-60 ft. lbs.
640-0003	50-60 ft. lbs.

HUBO WINDOW OPTIONS		
STEMCO BASE PART #	GREASE CAP PART #	OIL CAP PART #
4009	347-4278	347-4009
4195	347-4342	347-4195

HUB CAP COMPONENTS		
PART #	DESCRIPTION	TORQUE
359-6032	#8 Torx Screw	25 in. lbs. Maximum
359-5984	3/8 Mag Plug	5-9 ft. lbs. Maximum
359-5985	3/8 Pipe Plug	5-9 ft. lbs. Maximum

HUB CAP SPECIFICATIONS

HUB CAPS BY CAP NUMBER

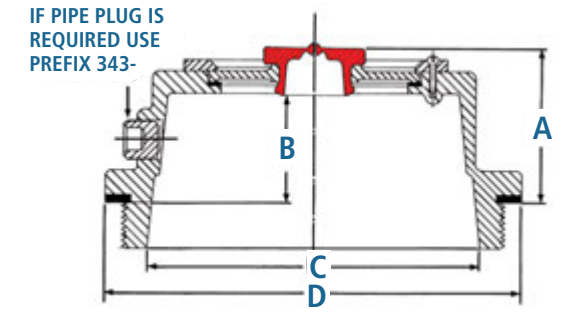
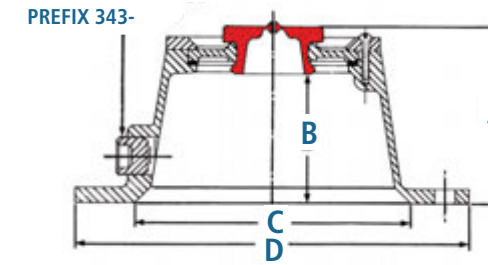

HUB CAP INCLUDES GASKET	BOLT CIRCLE	BOLT SIZE	NO. OF BOLTS	A HEIGHT	B INSIDE DEPTH	C FLANGE I.D.	D FLANGE O.D.	GASKET NUMBER	WINDOW KIT
	5-1/4	3/8	3	2-7/8	2-1/8	4-3/8	6	330-3002	359-5999
	5-1/2	5/16	6	2-11/16	1-15/16	4-3/8	6-1/4	330-3009	359-5995
	5-1/2	5/16	5	2-11/16	1-15/16	4-3/8	6-1/4	330-3013	359-5995
	5-1/4	3/8	3	3-1/2	2-3/4	4-1/8	Not Round	330-3019	359-5995
	4-1/2	5/16	6	2-5/8	1-7/8	3-1/2	5-1/4	330-3024	359-5999
	6-5/8	1/4	6	2-13/16	2-1/16	5-5/16	7-1/8	330-3034	359-5999
	5-1/8	5/16	6	1-7/8	1-1/8	4	5-11/16	330-3041	359-5999
	5-1/2	5/16	6	2-5/16	1-9/16	4-9/16	6-3/16	330-3009	359-5995
	3-5/8	5/16	4	2-1/4	1-1/2	2-3/4	4-1/2	330-3040	359-5990
	5-1/8	5/16	6	2-7/8	2-1/8	3-3/4	5-3/4	330-3041	359-5999
		6-1/4 X 8 UN (M)		2-5/16	1-9/16	5-3/4	6-7/8	330-3077	359-5995
	5-1/2	5/16	6	1-13/16	1-1/16	4-9/16	6-3/16	330-3009	359-5995
	5-1/2	5/16	6	1-1/4	1-1/8	4-7/16	6-3/16	330-3009	359-5912
	7-1/4	1/4	6	2-7/8	2-1/8	6-1/4	7-7/8	330-3084	359-5995
	7	5/8	8	2-1/16	1-5/16	4-5/16	8-1/4	330-3090	359-5995
	4-1/16	3/16	6	2-5/8	1-7/8	3-5/16	4-1/2	330-3094	359-5999
	5-9/16	5/16	6	2-7/8	2-1/8	3-11/16	6-3/8	330-3097	359-5999
	4	1/4	4	2-1/8	1-3/8	3-1/8	4-9/16	330-3102	NONE
	6	5/16	6	2-1/2	1-3/4	4-15/16	6-7/8	330-3060	359-5999
	5	5/16	4	2-1/8	1-3/8	4	5-3/4	330-3120	359-5999
	6-3/4	5/16	6	3-11/16	2-15/16	5-7/16	7-1/2	330-3118	359-5995
	5-1/2	5/16	6	1-13/16	1-11/16	4-7/16	6-3/16	330-3122	359-5912
	4-1/2	6mm	6	2-5/8	1-7/8	3-1/2	5-1/4	330-3024	359-5999
	5-17/32	3/8	6	2-5/16	1-9/16	4-9/16	6-3/16	330-3122	359-5995
	4-1/2	5/16	6	2-5/8	1-7/8	3-1/2	5-1/4	330-3024	NONE
		6-1/4 X 8 UN (M)		2-5/16	1-9/16	5-3/4	6-7/8	330-3077	NONE
	5-1/2	5/16	6	2-11/16	1-15/16	4-3/8	6-1/4	330-3009	359-6100
		6-1/4 X 8 UN (M)		2-5/16	1-9/16	5-3/4	6-7/8	330-3077	NONE
		6-1/4 X 8 UN (M)		2-5/16	1-9/16	5-3/4	6-7/8	330-3077	NONE
		6-1/4 X 8 UN (M)		2-5/16	1-9/16	5-3/4	6-7/8	330-3077	NONE
	3-5/8	5/16	4	2-1/4	1-1/2	2-3/4	4-1/2	330-3040	NONE

¹ Cannot be made with pipe plug

² Made with pipe plug only

³ Hub cap can be used with 5-1/2 or 5-9/16 bolt circle with 5/16 inch bolts

⁴ Hub cap available with hubo window, order 347-prefix. Also available 347-4342, which is 4195 hub cap for grease applications. Also available with Hubo window when ordered with 347 prefix. See options below.

⁵ Lexan hub caps, order in multiples of 25

⁶ 4009 with small vent plug 359-5915

⁷ 4024 with small vent plug

⁸ 4975 individually boxed

SENTINEL: KEEPING WATCH OVER WHEEL ENDS

- Prevents dirt and water from contaminating the oil, thereby extending seal and bearing life.
- Dramatically reduces contaminant build-up on hub cap windows, allowing for an accurate determination of lube levels.
- Eliminates early oil breakdown by preventing water contamination as a result of submerged axles.
- Provides maximum protection for maintenance-free wheel end systems.
- Improves performance and lowers overall maintenance costs.

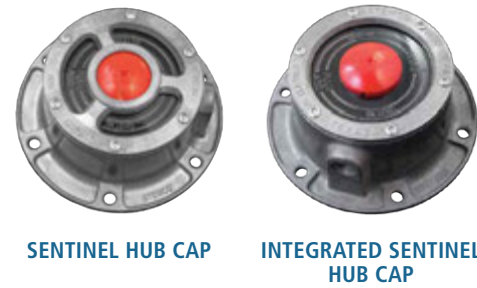

SENTINEL HUB CAP

INTEGRATED SENTINEL HUB CAP

SENTINEL HUB CAP

STEMCO BASE PART NO.	OIL CAP	GREASE CAP	BOLT CIRCLE	BOLT SIZE	NO. OF BOLTS	GASKET NUMBER	OIL WINDOW KIT	GREASE WINDOW KIT
4009	348-4009	349-4009	5 1/2"	5/16"	6	330-3009	359-6112	359-6120
4013	348-4013	349-4013	5 1/2"	5/16"	5	330-3013	359-6112	359-6120
4046	348-4046	349-4046	5 1/2"	5/16"	6	330-3009	359-6112	359-6120
4195	348-4195	349-4195	6 3/4"	5/16"	6	330-3118	359-6112	359-6120
4281	348-4281	N/A	5 17/32"	3/8"	6	330-3122	359-6112	359-6120

INTEGRATED SENTINEL HUB CAP

STEMCO BASE PART NO.	OIL CAP	GREASE CAP	BOLT CIRCLE	BOLT SIZE	NO. OF BOLTS	GASKET NUMBER	OIL WINDOW KIT	GREASE WINDOW KIT
4009	356-4009	358-4009	5 1/2"	5/16"	6	330-3009	359-6145	359-6146
4009	366-4009	368-4009	5 1/2"	5/16"	6	330-3009		
4013	356-4013	358-4013	5 1/2"	5/16"	5	330-3013	359-6145	359-6146
4024	366-4009	368-4009	5 1/2"	5/16"	6	330-3009		
4046	356-4046	358-4046	5 1/2"	5/16"	6	330-3009	359-6145	359-6146
4095	356-4095	358-4095	5 1/2"	5/16"	6	330-3009	359-6145	359-6146
4119	356-4119	358-4119	7	5/8"	8	330-3090	359-6145	359-6146
4195	356-4195	358-4195	6 3/4"	5/16"	6	330-3118	359-6145	359-6146
4195	360-4195	368-4195	6 3/4"	5/16"	6	330-3118		
4195	366-4195	368-4195	6 3/4"	5/16"	6	330-3118		

To relieve vacuum, the Sentinel interior check valve lifts slightly, drawing air into the wheel end through the water-resistant filter. The duck-bill check valve remains closed, blocking dirt, grime and other contaminants from entering.

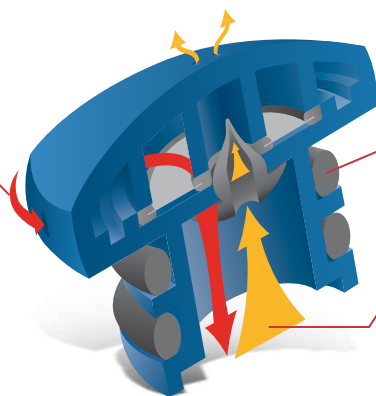

A second O-ring increases plug retention.

To relieve pressure, the duck-billed pressure relief valve opens, allowing pressure to vent out. The umbrella check valve remains closed, stopping lubricant from leaking out and contaminants from flowing in.

HUB CAP SPECIFICATIONS

SENTINEL® ESP (EXTENDED SERVICE PLUG)

STEMCO PART #	DESCRIPTION
359-6124	ESP Plus Plug Blister Pack (2/pk)
359-6125	ESP Plus Plug (bulk pack of 50)

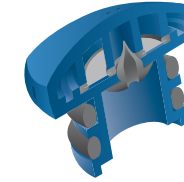

SENTINEL® ESP (STANDARD SERVICE PLUG)

STEMCO PART #	DESCRIPTION
359-6121	ESP Plug Blister Pack (2/pk)

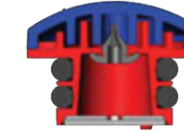

SENTINEL® ESP FILTERED VENT

STEMCO PART #	DESCRIPTION
359-6137	Drive Axle Vent (3/8" adapter)

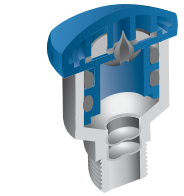

BULK PACK HUB CAPS WITH SENTINEL® ESP PLUG

SENTINEL ESP PART #	DESCRIPTION	BOLT CIRCLE	BOLT SIZE	# OF BOLTS	GASKET P/N
300-5009	4009 Cap, no side fill plug Bulk Pack (25/Box)	5-1/2"	5/16"	6	330-3009
303-5009	4009 Cap, with side fill plug Bulk Pack (25/Box)	5-1/2"	5/16"	6	330-3009

PSI READY HUB CAP

STEMCO PART #	GREASE CAP	OIL CAP	OIL CAP WITH MAGNETIC PIPE PLUG
4009	340-4370	343-4370	343-4373
4075		343-4371	343-4374
4195	340-4372	343-4372	
4384			
Window Kits	359-6141	359-6140	



Window kit consists of window, gasket and PSI retainer ring/gasket.

HUBO BRACKET FOR SENTINEL® AND PSI HUB CAPS

STEMCO PART #	STEMCO BASE PART #	PSI HUB CAP PART# (GREASE)	PSI HUB CAP PART# (OIL)	STUD SIZE	HEIGHT
610-0084	4195	340-4372	343-4372	5/16"	5
610-0028	4009	340-4370	343-4370	5/16"	5
610-0090	4075		343-4371	*	1 7/8

*Bracket mounts on top of window ring w/4 replacement screws included w/bracket.

HUB CAP SPECIFICATIONS

POPULAR HUB CAP OPTIONS WITH BOLT SPECIFICATIONS

STEMCO BASE PART #	PREFIX	4009	4013	4024	4046	4075	4095	4195	4249	4281	4370 ¹	4371 ¹	4372 ¹
STANDARD HUB CAP, NO SIDE FILL	340	X	X	X	X	X	X	X	X		X	X	X
DIRT EXCLUSION, GREASE	342	X	X	X		X	X	X	X				
STANDARD HUB CAP, SIDE FILL	343	X	X	X	X	X	X	X	X		X	X	X
STANDARD HUB CAP, HUBO WINDOW	347	X	X			X		X					
SENTINEL® HUB CAP	348	X	X		X	X	X	X		X			
SENTINEL® HUB CAP GREASE	349	X	X		X	X	X	X		X			
SOLID ALUMINUM GREASE / VENTED	352	X					X	X					
INTEGRATED SENTINEL® OIL	356	X	X	X	X	X	X	X					
INTEGRATED SENTINEL® GREASE	358	X	X	X	X	X	X	X					
BOLT CIRCLE		5-1/2	5-1/2	4-1/2	5-1/2	6-1/4 x 8 UN(M)	5-1/2 x 5/16	6-3/4	5-1/2	5-17/32	5-1/2		6-3/4
BOLT SIZE		5/16	5/16	5/16	5/16	6-1/4 x 8 UN(M)	5-1/2 x 5/16	5/16	5/16	3/8	5/16	6-1/4 x 8 UN(M)	5/16
# OF BOLTS		6	5	6	6			6	6	6	6		6

¹ PSI Hub Cap

HUB CAP CROSSOVER

COMPETITIVE PART #	COMPETITOR'S NAME	STEMCO PART #	COMPETITIVE PART #	COMPETITOR'S NAME	STEMCO PART #	COMPETITIVE PART #	COMPETITOR'S NAME	STEMCO PART #
1282	C/R	340-4975	506089	Eaton	343-4249	C43-4249	C/R	343-4249
1612	C/R	343-4024	64009	TriSeal	343-4009	DG-5/6P	Dual Dynamics	340-4013
1642	C/R	343-4013	64009H	TriSeal	347-4009	DG-5/6PS	Dual Dynamics	343-4013
1643	C/R	343-4249	64013	TriSeal	343-4013	DG-6F	Dual Dynamics	340-4046
1682	C/R	343-4075	64024	TriSeal	343-4024	DG-6F4.5	Dual Dynamics	340-4024
1696	C/R	343-4195	64046	TriSeal	343-4046	DG-6F4.5P	Dual Dynamics	343-4013
1703	C/R	343-4249	64046	TriSeal	343-4095	DG-6F4.5PC	Dual Dynamics	343-4024
1711	C/R	343-4024	64046	TriSeal	343-4249	DG-6FL	Dual Dynamics	340-4249
1742	C/R	343-4013	64075A	TriSeal	343-4075	DG-6FP	Dual Dynamics	347-4009
1743	C/R	343-4009	64075G	TriSeal	342-4075	DG-6FPC	Dual Dynamics	340-4024
1743	C/R	343-4046	64075P	TriSeal	340-4975	DG-6P	Dual Dynamics	340-4009
1743	C/R	343-4095	64249	TriSeal	343-4249	DG-6PS	Dual Dynamics	343-4009
1753	C/R	343-4249	812928	Eaton	343-4095	DG-6PSC	Dual Dynamics	340-4046
1788	C/R	343-4249	815214	Eaton	343-4195	DG-7.5P	Dual Dynamics	340-4195
1800	C/R	347-4009	821338	Eaton	343-4009	DG-7.5PS	Dual Dynamics	343-4195
1811	C/R	343-4024	821907	Eaton	343-4009	DG-P	Dual Dynamics	340-4075
1842	C/R	343-4013	C40-4009	C/R	340-4009	DG-PS	Dual Dynamics	343-4075
1843	C/R	343-4009	C40-4009BP	C/R	300-4009	DG-PSC	Dual Dynamics	343-4249
1843	C/R	343-4046	C40-4975	C/R	340-4975	H075	National	343-4075
1843	C/R	343-4095	C40-4975BP	C/R	340-4975	HU009A	National	343-4009
1890	C/R	343-4249	C40-5097BP	C/R	340-5097	HU009A	National	343-4046
340-009	National	340-4009	C43-4009	C/R	343-4009	HU013A	National	343-4013
340-009BK	National	300-4009	C43-4009BP	C/R	303-4009	HU024A	National	343-4024
340-975	National	340-4975	C43-4013	C/R	343-4013	HU110A	National	343-4095
340-975BK	National	340-4975	C43-4024	C/R	343-4024	HU110A	National	343-4249
343-009	National	343-4009	C43-4075	C/R	343-4075			
343-009BK	National	303-4009	C43-4095	C/R	343-4095			
506085	Eaton	343-4024	C43-4098	C/R	343-4098			

HUB CAP SPECIFICATIONS



340-5096



340-5097

STAMPED STEEL GREASE HUB CAPS

HUB CAP INCLUDES GASKET	BOLT CIRCLE	BOLT SIZE	NO. OF BOLTS	A HEIGHT	B INSIDE DEPTH	C FLANGE I.D.	D FLANGE O.D.	GASKET #
340-5096 ¹	5-1/2	5/16	6	2-1/2	2-13/32	4-3/8	6-1/4	330-3009
340-5097	5-1/2	5/16	6	2-1/2	2-13/32	4-3/8	6-1/4	330-3009
340-0044 ²	4-1/2	5/16	6	2	1-15/16	3-5/16	5-3/16	330-3024

¹ With Dirt Exclusion vent

² Painted black

SOLID GREASE HUB CAP/DUCKBILL VENTED

STEMCO PART #	BOLT CIRCLE	BOLT SIZE	# OF BOLTS	GASKET #
352-4009	5-1/2	5/16	6	330-3009
352-4195	6-3/4	5/16	6	330-3118
362-4195*	6-3/4	5/16	6	330-3118



352-4195

*No Duckbill Vent

DIRT EXCLUSION GREASE HUB CAPS

HUB CAP INCLUDES GASKET	BOLT CIRCLE	BOLT SIZE	NO. OF BOLTS	A HEIGHT	B INSIDE DEPTH	C FLANGE I.D.	D FLANGE O.D.	GASKET NUMBER	WINDOW KIT
342-4009	5-1/2	5/16	6	2-11/16	1-15/16	4-3/8	6-1/4	330-3009	359-6095
342-4013	5-1/2	5/16	5	2-11/16	1-15/16	4-3/8	6-1/4	330-3013	359-6095
342-4024	4-1/2	5/16	6	2-5/8	1-7/8	3-1/2	5-1/4	330-3024	359-6094
342-4075	6-1/4 x 8 UN(M)			2-5/16	1-9/16	5-3/4	6-7/8	330-3077	359-6095
342-4195	6-3/4	5/16	6	3-11/16	2-15/16	5-7/16	7-1/2	330-3118	359-6095



342-4009

*Window Kit consists of window, gasket and window ring gasket.

HUB CAP SPECIFICATIONS

COMPONENT SPECIFICATIONS



340-4075



570-7008



340-4975

4075 HUB CAP VARIATIONS

APPLICATION	PART NUMBER	DESCRIPTION
Oil	340-4975	Clear polycarbonate hub cap
Oil	343-4075	Cast aluminum hub cap with side fill plug
Oil	343-4371	Cast aluminum hub cap with PSI face & side fill plug
Oil	348-4075	Cast aluminum hub cap with Sentinel® Technology & side fill plug
Oil	353-4075	Cast aluminum hub cap with Sentinel® ESP plug & side fill plug
Grease/Oil	340-4075	Cast aluminum hub cap & no side fill plug
Grease	342-4075	Cast aluminum hub cap with dirt exclusion window
Grease	340-4320	Solid cast aluminum hub cap & no side fill plug
Grease	340-4976	Clear polycarbonate hub cap with solid face—no vent
Grease		Cast aluminum hub cap with Sentinel® Technology & no side fill plug
Grease	350-4075	Cast aluminum hub cap with Sentinel® ESP & no side fill plug

Screw-on Caps must have O-rings (330-3077).
Use 570-7008 tool to tighten pro-par hub caps.

VENTED HUBODOMETER® HUB CAPS

HUB CAP INCLUDES GASKET	GASKET PART #	BOLT CIRCLE DIAMETER	NUMBER OF HOLES	BOLT DIAMETER	ALUMINUM EQUIVALENT
640-0001*	641-0005	5-1/2	6	5/16	347-4009
640-0002*	641-0017	5-1/2	5	5/16	
640-0003*	330-3077		6-1/4 x 8 UN(M)		

*Vented

ACCESSORIES

DESCRIPTION	PART #
1-Pipe plug with O-ring	641-0001
2-Magnetic Pipe Plug	359-5984
3-Supporting hub cap flange 6 hole	641-0003

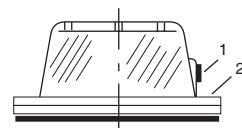

640-0001



640-0003

HUB CAP SPECIFICATIONS

COMPONENT SPECIFICATIONS

TYPICAL 4-3/8" WINDOW COMPONENT PARTS



TYPICAL 2-3/4" & 3-1/2" WINDOW COMPONENT PARTS

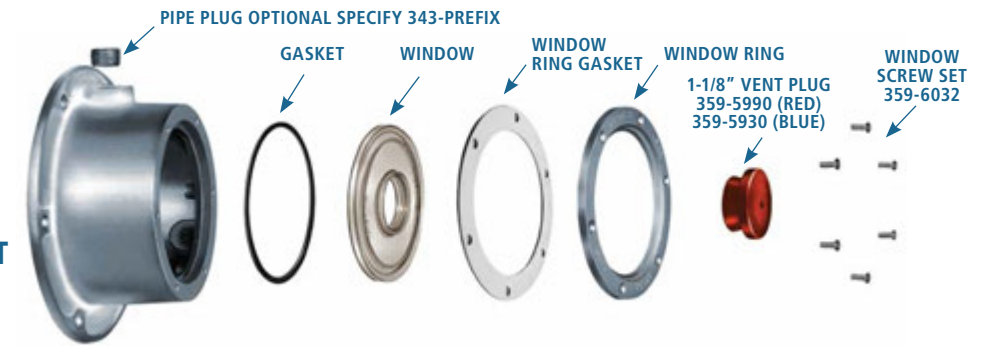

STANDARD HUB CAP REPLACEMENT COMPONENTS

3/8 PIPE PLUG ²	GASKET	WINDOW DIAMETER	WINDOW	WINDOW RING GASKET	WINDOW RING	VENT PLUG	WINDOW KIT ¹	SCREW SET 6/SET
359-5985	359-5996	2-3/4	359-5983	359-3136	359-5997 ³	359-5990 ⁴	359-5999	359-6032
359-5985	359-5991	3-1/2	359-5994	359-3127	359-5992	359-5990 ⁴	359-5995	359-6032
359-5985	359-5991	3-1/2	—	359-3127	359-5992	None	359-6117	359-6032
359-5985	359-5968	4-3/8	359-5918	359-3137	359-5970	359-5915	359-5912	359-6032 ⁶
359-5985	359-5991	3-1/2	359-6049 ⁵	359-3127	359-5992	359-5915	359-6100 ⁵	359-6032

¹ Window kit consists of window, gasket, window ring with gasket and vent plug

⁴ Blue vent plug part number 359-5930

² Magnetic pipe plug part number 359-5984

⁵ Window with recessed vent plug

³ 5 hole window ring

⁶ Two sets required

DIRT EXCLUSION GREASE HUB CAP REPLACEMENT COMPONENTS

WINDOW DIAMETER	WINDOW	GASKET	WINDOW RING	WINDOW RING GASKET	SCREW SET 6/SET	WINDOW KIT
2-3/4	359-6086	359-5996	359-5997	359-3136	359-6032	359-6094
3-1/2	359-6087	359-5991	359-5992	359-3127	359-6032	359-6095
4-3/8	359-6088	359-5968	359-5970	359-3137	359-6032 ⁷	359-6096

⁷ Two sets required

SENTINEL® HUB CAP REPLACEMENT COMPONENTS

WINDOW DIAMETER	WINDOW KIT ⁸	GASKET	WINDOW RING GASKET	SCREW SET 6/SET	MAGNETIC PIPE PLUG
3-1/2	359-6112 ⁹	359-5991	359-3127	359-6032	359-5984
3-1/2	359-6120 ¹⁰	359-5991	359-3127	359-6032	359-5984

⁸ Window kit consists of window, gasket, window ring with gasket and Sentinel red cap cover part number 359-6103.

⁹ Window kit for oil application

¹⁰ Window kit for grease application

HUB CAP SPECIFICATIONS

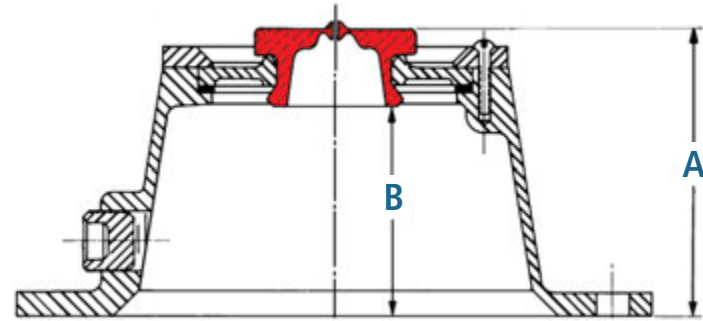

HUB CAP INTERCHANGE

This STEMCO hub cap interchange is arranged with hub caps in descending inside depth so that a cap can be replaced by any cap above it within its bolt circle group and without fear of spindle interference.

5-1/8" Bolt Circle with Six 5/16" Mounting Bolts

CAP NO.	INSIDE (B)	OUTSIDE (A)
340-4066	2-1/8	2-7/8
340-4042	1-1/8	1-7/8

5-9/16" Bolt Circle with Six 5/16" Mounting Bolts

CAP NO.	INSIDE (B)	OUTSIDE (A)
340-4149	2-1/8	2-7/8
340-4249 ¹	1-11/16	1-13/16

5-1/2" Bolt Circle with Six 5/16" Mounting Bolts

CAP NO.	INSIDE (B)	OUTSIDE (A)
340-4009	1-15/16	2-11/16
340-4249 ¹	1-11/16	1-13/16
340-4046	1-9/16	2-5/16
340-4281 ¹	1-9/16	2-5/16
340-4098	1-1/8	1-1/4
340-4095	1-1/16	1-13/16

NOTE: STEMCO does not recommend vehicle widths.

¹ Hub cap fits both 5-1/2" and 5-9/16" bolt circle with six 5/16" mounting bolts

FLANGE GASKET SPECIFICATIONS

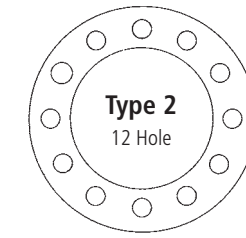
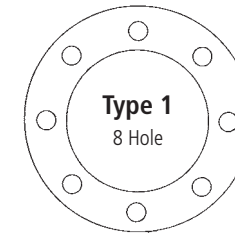

DRIVE AXLE FLANGE GASKET DIMENSIONS

STEMCO GASKET NO.	TYPE	I.D.	O.D.	BOLT CIRCLE	BOLT SIZE	NUMBER OF BOLTS
330-3036	1	5-1/2"	8-5/8"	7"	3/4"	8
330-3105	2	5-11/16"	7-7/16"	6-1/2"	1/2"	12
330-3106	1	6"	8-1/4"	7"	5/8"	8
330-3107	1	5-5/8"	8-1/2"	7"	3/4"	8
330-3108	1	4"	5-9/16"	4-3/4"	7/16"	8
330-3109	1	4-1/2"	6-1/8"	5-5/16"	1/2"	8
330-3110	1	5-3/8"	7-3/8"	6-3/8"	9/16"	8
330-3111	1	5-3/4"	8-3/8"	7"	5/8"	8
330-3112	1	4"	6-7/16"	5-1/2"	5/8"	8
330-3113	2	4-1/2"	6-1/16"	5-1/4"	1/2"	12
330-3114	2	5"	6-1/2"	5-11/16"	7/16"	12
330-3115	2	4-1/4"	6-1/8"	5-1/4"	1/2"	12

DRIVE AXLE FLANGE GASKET APPLICATIONS

STEMCO PART NO.	SAME AS	PART NO.	APPLICATION
330-3036	--	--	Eaton 38,000# tandem. IHC-RA355.
330-3105	Euclid	E 2340	All Meritor Standard Q wheel ends except some SQHP.
	White	476375	
330-3106	Euclid	E 2341	All Meritor Standard R wheel ends.
	Meritor	2208W412	
330-3107	Euclid	E 2431	All E18, E19, E38D & 44D series.
	Meritor	2208X440	
330-3108	Euclid	E 2432	Eaton 15 series.
330-3109	Euclid	E 2433	Eaton 30000# Tandem Meritor Standard SFHD & H wheel ends Eaton 17000# singles.
330-3110	Euclid	E 2434	Mack 38000# Tandem axles.
330-3111	Euclid	E 2435	All Meritor Standard R wheel ends, STD series, SUD series, U wheel ends, SFD 4600, SQHP, SQ100, SQ100P, 4640 Eaton.
	Meritor	2208W413	
	Kenworth	K134 - 171	
330-3112	White	453157	
330-3112	Euclid	E 2436	IHC 34000# - RA 351 axles.
330-3113	Euclid	E 2437	Meritor Standard L-172 Eaton 18 series and 34D.
330-3114	Euclid	E 2438	Meritor Standard L wheel ends except L-172, SJHD, SLHD.
	Meritor	2208Z422	
	White	467836	
330-3115	G.M.C.	2362158	Fits 1965 - 1974 G.M.C. - Chev. 18000# Single or 34000# Tandem Eaton 14569.

TRACKING DISTANCE? NO PROBLEM.

To make roadways safer, STEMCO has provided the trucking industry with reliable and innovative mileage solutions for more than 70 years. We leverage the latest technologies to provide solutions that reduce vehicle maintenance costs and increase fleet safety—helping fleets run a more cost effective business with maximum performance and value. Whether for maintenance purposes or logging miles, accuracy is critical – and STEMCO delivers this with data more accurate than competing GPS solutions.



HUBODOMETER®

Guaranteed to deliver the best in mileage accuracy, the Hubodometer® is the most economical, accurate and convenient way of tracking mileage for preventive maintenance, leases and warranties.

- Reliable mileage information
- Spring-loaded counter-weight eliminates spin for greater accuracy
- Preset your Hubodometer® to collect customized data
- 500,000-mile warranty
- Product number: 650-XXXX



DataTrac® DataTrac® PRO

With unparalleled accuracy, the DataTrac® and DataTrac® Pro Electronic Hubodometers are indispensable tools for scheduling maintenance, determining lease charges, and managing costs per mile.

- Large, easy-to-read LCD display
- Compact size, easy to mount
- 500,000 mile/4-year warranty
- No moving parts increases reliability and durability
- DataTrac is factory programmed
- DataTrac Pro is field programmable
- DataTrac product number: 600-5REV (miles), 600-4REV (kilometers)
- DataTrac Pro product number: 600-9999

DataTrac® SVT™

Handwritten logs aren't needed with the DataTrac® SVT Electronic Mileage Sensor, an electronic sensor that provides mileage collection and can schedule maintenance by mileage activity rather than time.

- Electronic mileage sensor
- 500,000 mile/4-year warranty
- Two versions available – Tamperproof and Lifetime Reprogrammable
- Wireless readings
- Easily imports readings to fleet management software
- DataTrac SVT (Reprogrammable) product number: 607-8004
- DataTrac SVT (Tamperproof) product number: 607-8005



GATE READER | SVT™

Automate and manage mileage and fuel information to improve fleet operations with the GateReader SVT, an innovative solution to better inform personnel by automatically collecting readings.

- Automatic data collection
- WiFi capability eliminates monthly cellular charges
- Reads all DataTrac® SVT sensor types
- Eliminates costly telematics hardware need for each trailer



DataTrac® Programmer

Working in conjunction with DataTrac® Pro, the DataTrac® Programmer can program in mileage presets and tire calibrations.

- Programmable to in mileage presets, tire calibrations, and distance units in miles, kilometers, revolutions with calibrations 1-1999.
- Easy-to-read LCD display
- Battery powered and portable for programming
- Product number: 801-6000



DataTrac® Battery

Significantly improved life of your equipment with the DataTrac® Battery.

- Now supporting battery life up to 10 years
- Extends warranty from three to four years



DATATRAC® PRO

- Scheduling maintenance
- Validating guarantees
- Determining lease charges
- Calculating costs-per-mile

TIRE MAKE	TIRE MODEL	TIRE SIZE	STEMCO MECHANICAL HUBO MILES / KM	VEEDER-ROOT P/N MILES / KM	DATATRAC PRO MILES / KM	*DATATRAC PRO REV - MILES / KM
Bridgestone	M726	11R22.5	650-0598 / 650-0537	777717-494 / 777727-306	600-5499 / 600-4310	499 / 310
Bridgestone	M726	11R24.5	650-0584 / 650-0528	777717-475 / 777727-294	600-5476 / 600-4296	476 / 296
Bridgestone	M726	255/70R22.5	650-0622 / 650-0549	777717-572 / 777727-350	600-5564 / 600-4351	564 / 351
Bridgestone	M726	285/75R24.5	650-0595 / 650-0537	777717-494 / 777727-306	600-5499 / 600-4310	499 / 310
Bridgestone	M726	295/75R22.5	650-0605 / 650-0541	777717-510 / 777727-316	600-5514 / 600-4320	514 / 320
Bridgestone	R194	11R22.5	650-0605 / 650-0541	777717-514 / 777727-316	600-5513 / 600-4319	513 / 319
Bridgestone	R194	11R24.5	650-0593 / 650-0534	777717-490 / 777727-306	600-5489 / 600-4304	489 / 304
Bridgestone	R194	255/70R22.5	650-0627 / 650-0552	777717-572 / 777727-359	600-5580 / 600-4361	580 / 361
Bridgestone	R194	285/75R24.5	650-0605 / 650-0541	777717-514 / 777727-316	600-5513 / 600-4319	513 / 319
Bridgestone	R194	295/75R22.5	650-0612 / 650-0545	777717-525 / 777727-326	600-5529 / 600-4328	529 / 328
Goodyear	G104	255/70R22.5	650-0627 / 650-0552	777717-572 / 777727-359	600-5579 / 600-4360	579 / 360
Goodyear	G124	11R22.5	650-0601 / 650-0537	777717-500 / 777727-310	600-5505 / 600-4314	505 / 314
Goodyear	G124	255/70R22.5	650-0626 / 650-0549	777717-572 / 777727-359	600-5572 / 600-4356	572 / 356
Goodyear	G167	11R22.5	650-0598 / 650-0537	777717-500 / 777727-310	600-5501 / 600-4311	501 / 311
Goodyear	G167	295/75R22.5	650-0605 / 650-0541	777717-514 / 777727-326	600-5515 / 600-4320	515 / 320
Goodyear	G314	11R22.5	650-0605 / 650-0541	777717-510 / 777727-312	600-5512 / 600-4318	512 / 318
Goodyear	G314	11R24.5	650-0593 / 650-0534	777717-484 / 777727-300	600-5488 / 600-4303	488 / 303
Goodyear	G314	285/75R24.5	650-0605 / 650-0541	777717-510 / 777727-316	600-5514 / 600-4320	514 / 320
Goodyear	G314	295/75R22.5	650-0613 / 650-0545	777717-520 / 777727-326	600-5529 / 600-4328	529 / 328
Goodyear	G362	11R24.5	650-0584 / 650-0528	777717-475 / 777727-300	600-5478 / 600-4297	478 / 297
Goodyear	G362	285/75R24.5	650-0598 / 650-0537	777717-500 / 777727-310	600-5501 / 600-4311	501 / 311
Goodyear	G362	295/75R22.5	650-0605 / 650-0541	777717-514 / 777727-326	600-5515 / 600-4320	515 / 320
Goodyear	G372	11R24.5	650-0584 / 650-0528	777717-475 / 777727-297	600-5476 / 600-4296	476 / 296
Goodyear	G372	285/75R24.5	650-0598 / 650-0537	777717-494 / 777727-310	600-5497 / 600-4309	497 / 309
Goodyear	G372	295/75R22.5	650-0605 / 650-0541	777717-510 / 777727-316	600-5512 / 600-4318	512 / 318
Michelin	XDA2	11R22.5	650-0598 / 650-0537	777717-500 / 777727-310	600-5502 / 600-4312	502 / 312
Michelin	XDA2	11R24.5	650-0587 / 650-0528	777717-475 / 777727-294	600-5480 / 600-4298	480 / 298
Michelin	XDA2	255/70R22.5	650-0625 / 650-0549	777717-572 / 777727-350	600-5566 / 600-4352	566 / 352
Michelin	XDA2	275/80R22.5	650-0605 / 650-0541	777717-510 / 777727-326	600-5519 / 600-4323	519 / 323
Michelin	XDA2	275/80R24.5	650-0598 / 650-0537	777717-500 / 777727-310	600-5502 / 600-4312	502 / 312
Michelin	XZA2	11R22.5	650-0601 / 650-0539	777717-510 / 777727-316	600-5510 / 600-4317	510 / 317
Michelin	XZA2	11R24.5	650-0591 / 650-0532	777717-484 / 777727-300	600-5485 / 600-4302	485 / 302
Michelin	XZA2	275/80R22.5	650-0610 / 650-0545	777717-520 / 777727-326	600-5526 / 600-4327	526 / 327
Michelin	XZA2	275/80R24.5	650-0601 / 650-0539	777717-510 / 777727-316	600-5509 / 600-4316	509 / 316
Michelin	XZE	255/70R22.5	650-0626 / 650-0549	777717-572 / 777727-359	600-5574 / 600-4357	574 / 357

* Indicates the revolutions per mile or kilometer used to program the DataTrac® Pro from the Program Part screen.
 * DataTrac® p/n 600-1xxx used for miles and 600-0xxx used for kilometers contain trip. Follow conversion from DataTrac® in the table above.
 * Mechanical hubodometers are designated for use in a "range" of RPM or RPK, not a "specific" RPM or RPK. For "exact" revolutions, use DataTrac® Pro.

HUBODOMETER® MOUNTS

POPULAR HUBODOMETERS® (IN POPULARITY ORDER)

PART #	RPM	BLANK TENTHS PART #	PART #	RPKM
650-0610	522	650-0611	650-0537	310
650-0598	500	650-0600	650-0532	300
650-0613	532	650-0614	650-0539	315
650-0601	504	650-0602	650-0545	324
650-0605	513	650-0606	650-0541	320
650-0587	480	650-0588	650-0549	357

HUBODOMETER® BRACKETS

PART #	BOLT CIRCLE	STUD SIZE	HEIGHT	PART #	STYLE
6100001	5 1/4	1/2	1 11/16		A
6100002	5 1/2	5/8	1 11/16		A
6100003	6 3/8 – 6 1/2	1/2 – 9/16	1 11/16		A
6100005	7 1/4	9/16	1 11/16		A
6100006	7	5/8	1 11/16		A
6100007	7	3/4	1 11/16		A
6100008	7 1/2	5/8	1 9/16		A
6100009	7 1/2	5/8	3 11/16		A
6100010	8 5/8	5/8	5 7/16	Mack Mount	A
6100011	5 1/2 – 7 1/2	1/2	1 3/4	Universal Mount	
6100013	5 1/2	7/16	1/4		A
6100014	7 5/8	5/8	4 3/8		A
6100017	5 7/32	5/8	1 11/16		A
6100022	3 9/16	1/2	1/2	Strap and Lock Assembly	
6100023	3 15/16	1/2	1		A
6100024	5 1/2	5/16 – 18 thd	4 1/2	Hardware for Berg Cap	
6100025	4 1/2 – 9	3/16	1 11/16	TMK-90 Truck Mount	
6100028	5 1/2	5/16	5	Sentinel and PSI Caps – 3 Leg	
6100029	6 3/4	5/16	6	Sentinel, PSI, AirGo Caps – 3 Leg	
6100032	7 1/4	9/16	1 1/2		A
6100058	6 1/2	1/2	4 1/2		A
6100059	4	9/16	1 1/2	For Golf Carts	A
6100065	5 1/2	5/16	3 1/2	Fits 4009 Hubcap	A
6100066	6 1/2	5/8	5 1/4		A
6100079	7 1/4	3/4	1 11/16		A
6100084	6 3/4	5/16	5	Sentinel and PSI Caps – 3 Leg, f/4195	
6100085	5 1/2	5/16	4	PSI Caps	A
6100090	N/A	N/A	N/A	Mounts on Top of Window Ring	
6100093	262 mm (10.31")	M10	N/A	Meritor Planetary Axle-DTrac Only	
6100094	246 mm (9.70")	M10	N/A	MAN Planetary Axle-DTrac Only	
6410023	N/A	N/A	N/A	Refurb Kit f/MAN Bracket	

HUBODOMETER® HUB CAPS – FOR TRAILER INSTALLATIONS

HUB CAP INCLUDES GASKET	GASKET PART #	BOLT CIRCLE DIAMETER	# OF HOLES	BOLT DIAMETER	ALUMINUM EQUIVALENT
640-0001*	641-0005	5-1/2	6	5/16	347-4009
640-0002*	641-0017	5-1/2	5	5/16	
640-0003*	330-3077		6-1/4 x 8 UN(M)		

*Vented



COMPONENT SPECIFICATIONS

INSTALLATION TOOLS

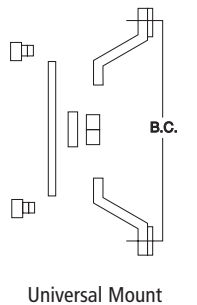
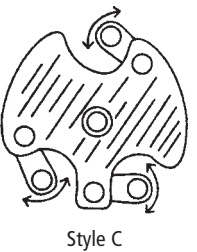
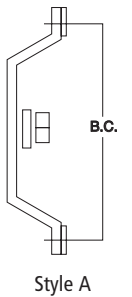

ENJOY OPTIMAL PERFORMANCE WITH PRECISE INSTALLATION

Every truck component is critical in ensuring exceptional performance, and that makes proper component installation even more critical. STEMCO axle tools are engineered to fit your STEMCO seals perfectly so installation is fast and easy. Because the fit is spot on, our axle tools prevent damage of the seals and neighboring components so everything stays in optimal shape. Without the risk of damage, you can relax knowing your STEMCO seals will be doing their job — keeping your truck on the road longer and making the roadways safer.

UNIVERSAL AXLE TOOLS

UNIVERSAL AXLE TOOLS BY GUARDIAN® SEAL NUMBER

GUARDIAN® SEAL	INNER BEARING CONE NUMBER	INNER BEARING CONE ID OR SPINDLE OD	UNIVERSAL AXLE TOOL HEAD	GUARDIAN® SEAL	INNER BEARING CONE NUMBER	INNER BEARING CONE ID OR SPINDLE OD	UNIVERSAL AXLE TOOL HEAD
307-0713 ¹	663	3.250	555-5100	308-0870	JF7049A	2.756	555-5297
307-0723 ¹	HM518445	3.500	555-5023	309-0903 ¹	580/582	3.250	555-5072
307-0743 ¹	HM218248	3.542	555-5039	309-0904 ¹	663/HM516449,-C	3.250	555-5072
307-0744	665A	3.375	555-5069		HM516449A	3.250	555-5073
	39581	2.250	555-5062	309-0912	47685/47686	3.250	555-5031
308-0836 ¹	HM212044,557A	2.375	555-5061		47678/5760	3.000	555-5074
	HM212049,-X	2.625	555-5098	309-0935	33287	2.875	555-5011
	HM212047	2.500	555-5066		33281	2.812	555-5002
308-0853	641/HM212049	2.625	555-5060	309-0948	687/780	4.000	555-5004
	H715345	2.812	555-5070	309-0961	580/582/663A	3.250	555-5072
308-0855	641	2.625	555-5060	309-0965	595	3.250	555-5072
	39581	2.250	555-5062		598	3.625	555-5071
308-0863	45284	2.000	555-5064	309-0973 ¹	594/594A	3.750	555-5076
308-0864 ¹	6461A	3.000	555-5007		598/598A	3.625	555-5071
	JM207049	2.165	555-5088				
308-0866	JM205149	1.968	555-5089				

Use Universal Tool Body 555-0001 with 555 Series Tool Heads.
¹ HP Design

UNIVERSAL AXLE TOOLS

UNIVERSAL AXLE TOOLS BY AXLE/DEFLECTOR RING NUMBER

AXLE RING	SEAL SET	INNER BEARING CONE NUMBER	INNER BEARING CONE ID OR SPINDLE OD	UNIVERSAL AXLE TOOL HEAD	AXLE RING	SEAL SET	INNER BEARING CONE NUMBER	INNER BEARING CONE ID OR SPINDLE OD	UNIVERSAL AXLE TOOL HEAD
310-1008	382-8066	JM207049	2.165	555-5088	310-1132	383-8139	663/641		
	382-8066	JM205149	1.968	555-5089	315-1501	392-9099	47685, 47686	3.250	555-5031
310-1012	392-9012	47686	3.250	555-5031		392-9099	47678	3.000	555-5074
	392-9012	5760,47678	3.000	555-5074		392-9087	681A	3.625	555-5071
310-1013	382-8001	6379	2.562	555-5014	315-1502	392-9087	683	3.750	555-5076
	382-8001	6386, 6389	2.625	555-5060		392-9097	594A,598A	3.625	555-5071
310-1022	372-7022	593	3.500		315-1503	372-7091	749, 749S	3.347	555-5024
310-1023	372-7024	749, 749S	3.347	555-5024		372-7099	HM518445	3.500	555-5023
		HM518445	3.500	555-5023	315-1504	372-7097	HM218248	3.542	555-5039
		557A, HM212044	2.375	555-5061	315-1506	372-7096	787	4.125	555-5016
310-1036	382-8036	HM212047	2.500	555-5066	315-1507	372-7098	663	3.250	555-5100
		HM212049,-X	2.625	555-5098		392-9092	598	3.625	555-5071
310-1037	382-8064	6461A	3.000	555-5007	315-1508	392-9096	598	3.625	555-5071
310-1038	382-8039	HM212049, 641	2.625			392-9096	595	3.250	555-5072
310-1063	392-9036	33281	2.812	555-5002	315-1510	372-7095	665A	3.375	555-5069
310-1064	372-7049	JM511946	2.557	555-5055	315-1511	392-9094	580, 582	3.250	555-5072
		3984	2.625	555-5097	315-1515	392-9112	663, HM516449	3.250	555-5072
310-1089	392-9053	782	4.125	555-5016	315-1516	392-9089	687, 780	4.000	555-5004
310-1093	382-8056	H715345	2.812	555-5070		392-9130	HM516449A	3.250	555-5073
	382-8056	641	2.625	555-5060	315-1525	392-9131	598A	3.625	555-5071
310-1107	392-9066	594A	3.750	555-5076		392-9131	594A	3.750	555-5076
310-1130	372-7062	592A, 593	3.500	555-5023	315-1530	392-9132	594A	3.750	555-5076
						392-9132	598A	3.625	555-5071

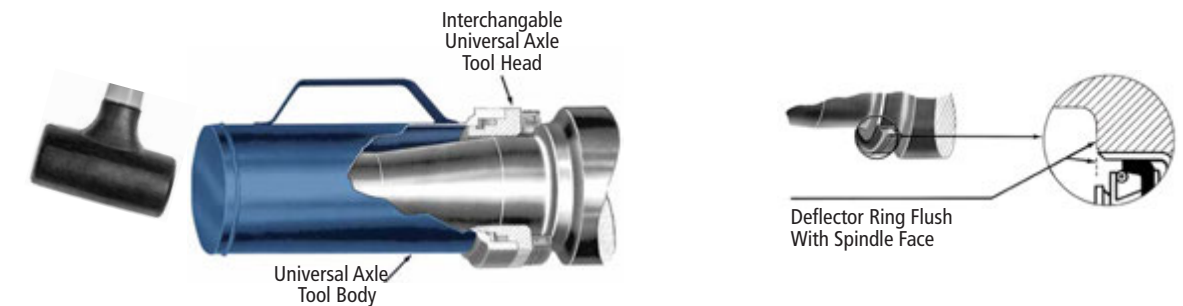

Use Universal Tool Body 555-0001 with 555 Series Tool Heads.

UNIVERSAL AXLE TOOLS

UNIVERSAL AXLE TOOLS BY TOOL HEAD NUMBER

UNIVERSAL AXLE TOOL HEAD NO.	INNER CONE	GUARDIAN® SEAL AXLE RING OR DEFLECTOR RING	UNIVERSAL AXLE TOOL HEAD NO.	INNER CONE	GUARDIAN® SEAL AXLE RING OR DEFLECTOR RING	UNIVERSAL AXLE TOOL HEAD NO.	INNER CONE	GUARDIAN® SEAL AXLE RING OR DEFLECTOR RING
555-5001	3778	310-1061	555-5060	641	308-0853	555-5073	HM516449A	315-1519
555-5002	33281	309-0935 310-1062		HM212049	308-0855	555-5074	47678	309-0912
555-5004	687 780	309-0948 315-1516		6386A	310-1009		5760	310-1012
555-5007	6461A	308-0864	6386	310-1013	495AX		310-1018	
555-5011	33287 567	309-0935 310-1062	555-5061	6389	310-1093	42688	575	310-1053
				555-5014	6379	310-1013	594A	309-0960
555-5016	782, 787	310-1089 315-1506	555-5062	HM212044	308-0836	594	309-0970	309-0973
				555-5023	HM518445	307-0723	683XA	310-1093
555-5024	749 749S	310-1005 315-1503	555-5064	557A	308-0836	594	310-1233	315-1502
				555-5029	759	310-1023	683	315-1517
				555-5031	6580	310-1023	598A	315-1525
555-5036	45284, 45285	310-1052	555-5066	593	315-1503	598A	315-1530	391-9066
				555-5039	592A	315-1503	760	310-1045
555-5054	188931	310-1068 310-1104	555-5069	665A	307-0744	683XA	310-1095	310-1095
				555-5041	593	315-1510	598A	310-1079
555-5055	JM511946	310-1064	555-5071	758	315-1510	681A	315-1502	308-0866
				555-5046	598	309-0973	315-1508	308-0866
555-5059	JM511946	310-1064	555-5072	598	315-1508	HM212049,-X	308-0836	308-0836
				555-5051	598A	315-1525	663, 6386	307-0713
555-5063	JM511946	310-1064	555-5073	681A	315-1530	H414245A	381-0148	381-0148
				555-5061	H715345	309-0903	32219	391-0138
555-5065	JM511946	310-1064	555-5074	580	309-0904	HM212047	381-0150	381-0150
				555-5062	582	309-0961	32216	391-0139
555-5067	JM511946	310-1064	555-5075	663-A,	310-1053	JF7049A	308-0870	308-0870
				555-5064	HM516449,-A	310-1093		
555-5069	JM511946	310-1064	555-5076	595	315-1508			
				555-5065	598	315-1509		
555-5071	JM511946	310-1064	555-5077	6559	315-1511			
				555-5066	315-1515			

FLEET HUB TOOLS

FLEET HUB TOOLS BY STANDARD/GRIT GUARD® OIL SEAL NUMBER

OIL SEAL	HUB TOOL	HUB-SEAL SETS	OIL SEAL	HUB TOOL	HUB-SEAL SETS
320-2001	551-5398	392-9001	320-2102	551-5318	392-9099
320-2007	551-5326	372-7045	320-2106	551-5320	392-9131
320-2012	551-5405	392-9012	320-2109	551-5313	372-7098
320-2018	551-5351	382-8018	320-2110	551-5412	372-7097
320-2021	551-5385	392-9021	320-2111	551-5323	372-7096
320-2023	551-5401	372-7020, 372-7022, 372-7062, 372-7099	320-2114	551-5412	392-9096
320-2028	551-5385	392-9043	320-2115	551-5356	392-9020, 392-9066, 392-9132
320-2029	551-5386	372-7018, 382-8029	320-2116	551-5317	382-8047
320-2031	551-5388	372-7055, 372-7056, 382-8025	320-2118	551-5321	372-7095
320-2032	551-5388	372-7009	320-2129	551-5393	392-9094
320-2036	551-5346	382-8036	320-2131	551-5363	392-9092
320-2039	551-5395	382-8023, 382-8039	320-2136	551-5381	372-7049
320-2041	551-5398	372-7004, 372-7015, 372-7017	320-2137	551-5327	382-8064
320-2046	551-5388	372-7005, 372-7006	320-2162	551-5333	392-9087
320-2051	551-5388	372-7008	320-2164	551-5366	382-8066
320-2057	551-5353	392-9036	320-2166	551-5340	382-8069
320-2059	551-5317	See 392-9053 Remarks	320-2173	551-5401	372-7024, 372-7026, 372-7027, 372-7028, 372-7091
320-2061	551-5356	392-9034	320-2199	551-5344	382-8056
320-2072	551-5308	372-7048	320-2213	551-5364	392-9112, 392-9130
320-2086	551-5311	382-8001	320-2216	551-5403	382-8071
320-2097	551-5400	392-9089			
320-2099	551-5317	392-9053			

NOTE: In order for STEMCO warranty to apply, the product must be correctly installed with an installation tool manufactured by STEMCO.

FLEET HUB TOOLS BY VOYAGER® & DISCOVER® XR NUMBER

VOYAGER®/ DISCOVER® XR	HUB TOOL	VOYAGER®/ DISCOVER® XR	HUB TOOL	VOYAGER®/ DISCOVER® XR	HUB TOOL	VOYAGER®/ DISCOVER® XR	HUB TOOL
373-0113	551-5313	383-0139	551-5413	393-0104	551-5414	320-2059	551-5317
373-0123	551-5401	383-0156	551-5344	393-0112	551-5416	320-2061	551-5356
373-0423	551-5401	383-0164	551-5327	393-0134	551-5421	320-2072	551-5308
373-0143	551-5412	383-0464	551-5327	393-0148	551-5400	320-2077	551-5362
373-0443	551-5412	383-0166	551-5423	393-0173	551-5320	320-2086	551-5311
373-0144	551-5339	383-0171	551-5403	393-0473	551-5320	320-2091	551-5312
383-0101	551-5420	393-0103	551-5415	320-2058	551-5303		
383-0136	551-5346						
383-0436	551-5346						

Use Universal Tool Handle 551-0001 with 551 Series Tool Heads.

FLEET HUB TOOLS

FLEET HUB TOOLS BY TOOL HEAD NUMBER

TOOL NO.	SEAL NO.	TOOL NO.	SEAL NO.	TOOL NO.	SEAL NO.	TOOL NO.	SEAL NO.
551-5302	320-2056	551-5339	373-0144	551-5381	320-2022 320-2136	551-5403	320-2216 383-0171
551-5303	320-2058	551-5344	320-2199 383-0156	551-5383	320-2104	551-5404	320-2233
551-5308	320-2072	551-5346	320-2036 383-0136 383-0436	551-5385	320-2028	551-5405	320-2012
551-5311	320-2086	551-5347	320-2050	551-5386	320-2029	551-5412	320-2110 320-2113 320-2114 373-0143 373-0443
551-5312	320-2091	551-5349	320-2181	551-5387	320-2034	551-5413	383-0139
551-5313	373-0113 320-2109	551-5351	320-2018 320-2105	551-5388	320-2031 320-2032 320-2046 320-2125	551-5414	393-0104
551-5317	320-2059 320-2099 320-2116	551-5353	320-2057 320-2119 320-2133	551-5389	320-2129	551-5415	393-0103
551-5318	320-2102	551-5356	320-2009 320-2061 320-2115	551-5393	320-2129	551-5416	393-0112
551-5320	320-2106 393-0173 393-0473	551-5362	320-2077	551-5395	320-2039	551-5420	383-0101
551-5321	320-2118	551-5363	320-2131	551-5398	320-2001 320-2041	551-5421	393-0134
551-5323	320-2111	551-5364	320-2213 393-0104	551-5400	320-2097 393-0148	551-5423	383-0166
551-5325	320-2117	551-5366	320-2164	551-5401	320-2023 320-2173 373-0123 373-0423		
551-5327	320-2137 383-0164 383-0464						
551-5333	320-2162						

Use Universal Tool Handle 551-0001 with 551 Series Tool Heads.

NOTE: In order for STEMCO warranty to apply, the product must be correctly installed with an installation tool manufactured by STEMCO.

BEARING GUIDES BY CONE NUMBER

BEARING NO.	GUIDE NO.	BEARING NO.	GUIDE NO.	BEARING NO.	GUIDE NO.	BEARING NO.	GUIDE NO.
387AS	570-0017	641	570-0020	3984	570-0020	42687	570-0022
495AX	570-0022	663	570-0023	3994	570-0020	42688	570-0022
555S	570-0017	663A	570-0023	5584	570-0019	47678	570-0022
557A	570-0018	665	570-0024	5760	570-0022	47685	570-0023
559	570-0019	665A	570-0024	6386	570-0020	47686	570-0023
575	570-0022	681A	570-0027	6386A	570-0020	188931	570-0017
580	570-0023	683	570-0028	6389	570-0020	7451929	570-0017
582	570-0023	683XA	570-0028	6461	570-0022	H715345	570-0021
593	570-0025	687	570-0032	6461A	570-0022	HM212044	570-0018
594	570-0028	748S	570-0022	6559	570-0023	HM212046	570-0019
594A	570-0028	749A	570-0023	6580	570-0025	HM212047	570-0019
595	570-0023	758	570-0024	33212	570-0031	HM212049	570-0020
598	570-0027	759	570-0025	33281	570-0021	HM212049X	570-0020
598A	570-0027	760	570-0026	39250	570-0019	HM218248	570-0026
623	570-0017	843	570-0022	39581	570-0017	HM516449,-A,-C	570-0023
639	570-0019	3982	570-0019	30585	570-0019	HM518445	570-0025
						JM205149A	570-0033
						JM207049A	570-0036

High impact, accurate guides designed to align the STEMCO seal with the hub bore, thereby eliminating the cocked seal. To be used with the designated hub tool designed for the seal being installed.

MISCELLANEOUS TOOLS

TOOL	TOOL NO.
Grease Template Fill Tool	102-5015

HEAVY DUTY AXLE TOOLS

HEAVY DUTY AXLE TOOLS BY GUARDIAN® SEAL NUMBER

GUARDIAN® SEAL	INNER CONE	OUTER CONE	TOOL NUMBER	GUARDIAN® SEAL	INNER CONE	OUTER CONE	TOOL NUMBER
307-0713 ¹	663	560	552-5212	309-0904 ¹	663	575	552-5226
		HM212049	552-5359		HM516449-C	47679	552-5226
307-0723 ¹	HM518445	HM518445	552-5239	309-0912	47685	39590	552-5359
307-0743 ¹	HM218248	HM212049	552-5236		47686	39590	552-5359
307-0744	665A	HM212049	552-5233	309-0961	580	42687	552-5221
	HM212044	3782	552-5206		582	42687	552-5221
308-0836 ¹	557A	3782	552-5206		663A	42687	552-5221
	HM212049,-X	3782	552-5288	309-0973 ¹	598A	580	552-5214
	HM212047	3782	552-5230		598	575	552-5215
308-0853	H715345	3979	552-5223		594	580	552-5216
308-0864 ¹	6461A	5555	552-5220		594A	580	552-5216
		3979	552-5220				
309-0903 ¹	580	567	552-5221				
	582	567	552-5221				

NOTE: In order for STEMCO warranty to apply, the product must be correctly installed with an installation tool manufactured by STEMCO.

NOTE: If heavy duty tool is not listed for a specific ring/seal use the 555 series tool head for that application.

¹ HP Design

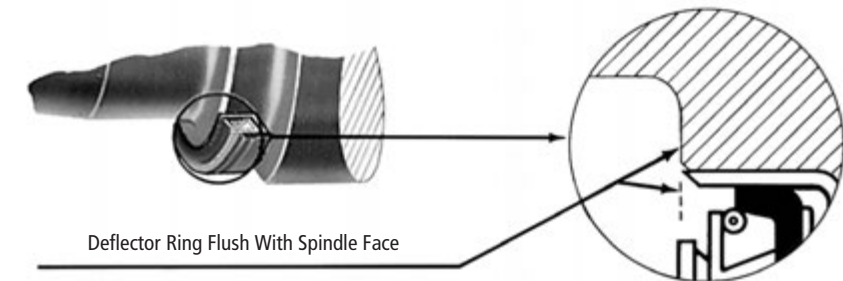

HEAVY DUTY AXLE TOOLS

HEAVY DUTY AXLE TOOLS BY AXLE/DEFLECTOR RING NUMBER

AXLE RING/ DEFLECTOR RING	SET NUMBER	INNER CONE	OUTER CONE	TOOL NUMBER	AXLE RING/ DEFLECTOR RING	SET NUMBER	INNER CONE	OUTER CONE	TOOL NUMBER
310-1012	392-9012	47686	39590	552-5359	315-1503	372-7099	HM518445	HM518445	552-5239
310-1034	382-8071	HM212047	3779, 45282	552-5230	315-1504	372-7097	HM218248	HM212049	552-5236
310-1036	382-8036	HM212044 HM212047 HM212049,-X	3782	552-5206 552-5230 552-5288	315-1506	372-7096	787	6580	
310-1037	382-8064	6461A	5555, 3979	552-5220	315-1507	372-7098	663	HM212049	552-5359
310-1043	372-7015	759	740		315-1508	392-9096	598	575	552-5215
310-1064	372-7049	JM511946	JM205149	552-5273	315-1510	372-7095	665A	HM212049	552-5233
310-1093	382-8056	H715345	28682, 5555	552-5223	315-1511	392-9094	580, 582	567	552-5221
310-1130	372-7062	593	65390 HH506348	552-5239	315-1515	392-9112	663, HM516449,-C	575, 47679	552-5226
315-1501	392-9099	47685, 47686	39590	552-5359	315-1516	392-9089	780	776, 864	552-5271
		681A	580	552-5214			598	575	552-5215
	392-9087	683	580	552-5216	315-1525	392-9131	594, 594A	580	552-5216
		681A	575	552-5215			598A	580	552-5214
315-1502	392-9132	598A	582	552-5214					
		598	575	552-5215					
	392-9131	594, 594A	580	552-5216					
		598A	580	552-5214					

NOTE: If heavy duty tool is not listed for a specific ring/seal use the 555 series tool head for that application.

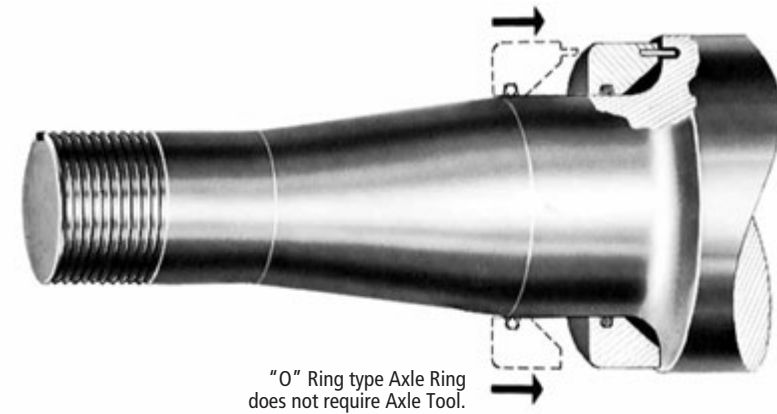

HEAVY DUTY AXLE TOOLS

HEAVY DUTY AXLE TOOLS BY TOOL NUMBER

TOOL NUMBER	INNER CONE	OUTER CONE	DEFLECTOR RING	TOOL NUMBER	INNER CONE	OUTER CONE	DEFLECTOR RING
552-5214	598A, 681A	580, 582, 575	309-0973 315-1502 315-1525 315-1530	552-5226	663, HM516449,-C	575, 47679	309-0904 310-1007 315-1515
552-5215	598, 598A, 681A	575	309-0973 315-1502 315-1508 315-1525 315-1530	552-5230	HM212047	3779, 45282	310-1034
552-5216	594A, 594, 683, -XA	HM516449, 580, 560, 582, 575	309-0973 310-1093 315-1502 315-1517 315-1525	552-5233	665A	HM212049, 641	307-0744 315-1510
552-5220	6461A	5555,3979	308-0864	552-5236	HM218248	HM212049	307-0743 315-1504
552-5221	580, 582	567, 575	309-0903 310-1053 315-1511	552-5239	HM518445	HM518445	307-0723 310-1023 315-1503
552-5223	H715345	3979, 28682	308-0853 308-0855 309-0903 310-1093	552-5288	HM212049, -X, X1	3782	308-0836
				552-5359	663, 47685, 47686	560, HM212049, 39590	307-0713 309-0912 310-1012 310-1013 310-1057 315-1501 315-1507

NOTE: In order for STEMCO warranty to apply, the product must be correctly installed with an installation tool manufactured by STEMCO.

NOTE: Hammer Assembly 552-5357.

TOOL BOARDS

TOOL BOARD	PART NO.
HUB SEAL	570-7032
AXLE	570-7033

GET PEACE OF MIND WITH AXLE FASTENERS THAT MEET YOUR NEEDS

Combining precision and ease of installation, STEMCO's lineup of axle fasteners give fleet managers options to meet their specific needs when it comes to securing wheel ends and preventing backoff. With increments down to 0.001", Pro-Torq® fasteners deliver precise bearing adjustments to maximize radial tire life and minimize component wear. Zip-Torq® takes the guesswork out of bearing adjustment with its robust single piece design, while Auto-Torq®, which securely applies the optimum clamp load on the bearings every time, is an all-in-one solution that's compatible with any industry hub manufacturer.



AXLE FASTENER INTERCHANGE

INSTALLATION TOOLS



Auto-Torq Axle Fastener

Safe, secure and simple, Auto-Torq requires no torque wrench to set the wheel end in optimum bearing adjustment for maximum life.

- Eliminates complex processes and specialty tools required with current market axle fasteners
- Sets optimum bearing adjustment automatically
- Quicker install time with peace of mind that installation is done correctly



Zip-Torq® Axle Fastener

This robust single piece spindle nut uses a patented self-locking ratchet system to secure the wheel end and prevent back off.

- Allows installation without special tooling. No clips, keepers, snap rings, or screws to install
- Integrated locking system prevents backoff
- Bearing contact surface is induction hardened for superior wear resistance



Pro-Torq® Axle Fastener

With back off increments down to 0.001 inch, Pro-Torq minimizes wheel-bearing adjustment variability, providing extended maintenance intervals and trouble-free performance.

- Controls axial motion, holding bearing end play near zero for longer tread life.
- Gives fleets the tightest adjustment standard in the industry
- One-nut design eliminates potential for overtightening

TRUCK/TRAILER	AXLE APPLICATIONS	PRO-TORQ® P/N	REPLACEMENT KEEPER P/N	THREAD SIZE	OUTER BEARING CONE / CUP
Trailer	Trailer (P)	447-4723	450-4723 (Tang)	3.480"-12	HM518445 / HM518410
Trailer	Trailer (N)	447-4743	450-4743 (Tang)	2 5/8"-16	HM212049 / HM212011
Truck	Steer (FF)	448-4836	450-4836 (D-Flat)	1 1/2" - 12	3782 / 3720
Truck	Steer (FF)	448-4837	450-4837 (Tang)	1 1/2" - 18	3782 / 3720
Truck	Steer (Mack)	448-4864	450-4864 (Tang)	2" - 12	552A / 555S
Truck	Truck (FL)	448-4865	450-4865 (D-Flat)	1 3/4" - 12	552A / 555S 3979 / 3720
Truck	Drive (R)	449-4973	450-4973 (Tang)	3 1/4" - 12	580 / 572
Truck	Drive (Mack)	449-4904	450-4904 (Tang)	2 7/8" - 12	563 / 567, 572 / 575, 47620 / 47679
Truck	Drive (Ford)	449-4974	450-4743 (Tang) (fits 3/8" keyway)	2 5/8" - 12	3984 / 3920, 39590 / 39520
Truck	Drive (School Bus)	449-4975	450-4975 (Tang)	2 5/8"-12	3984 / 3920, 39590 / 39520

PRO-TORQ® TOOL SOCKET	ZIP-TORQ® P/N	ZIP-TORQ® TOOL SOCKET	AUTO-TORQ® P/N	AUTO-TORQ® TOOL SOCKET
120mm - 8 point OTC#1961M or 4 13/16" - 8 point OTC#1941	400-4723	4 1/8" - 6 point OTC#1915	480-4723	120mm - 8 point OTC#1961M
3 3/4" - 8 point OTC #1925	400-4743	3 1/4" - 6 point OTC#1908	480-4743	3 7/8" - 8 point OTC#1913
2 1/2" - 6 point OTC#1921	400-4836	2 1/8" - 6 point OTC#1976		
2 1/2" - 6 point OTC#1921	400-4837	2 1/8" - 6 point OTC#1976		
3" - 6 point OTC#1906	400-4864	2 7/8" - 6 point OTC#1932		
3" - 6 point OTC#1906	400-4865	2 7/8" - 6 point OTC#1932		
4 3/8" - 8 point OTC#1917	400-4973	4" - 6 point OTC#1914	480-4973	120mm - 8 point OTC#1961M
4 1/8" - 6 point OTC#1915	400-4904	3 1/2" - 6 point OTC#1910		
3 3/4" - 8 point OTC#1925				
3 3/4" - 8 point OTC#1925				

CROSS REFERENCE

Information contained in this section is furnished as a guide. Verify specific application elsewhere in this catalog when possible.

COMPETITIVE PART NO.	COMPETITOR'S NAME	STEMCO MISC PRODUCTS	STEMCO STD/ GRIT GUARD®	STEMCO GUARDIAN®	STEMCO VOYAGER®	DISCOVER® XR
01005503	Dexter		372-7097	307-0743	373-0143	373-0443
02000655	Timpte	330-3009				
02009111	Timpte		372-7097	307-0743	373-0143	373-0443
02009913	Timpte	340/343-4009				
027003942	GMC/Volvo	343-4249				
027023479	Western Star	343-4095				
027074450	GMC/Volvo	320-2106				
027074962	GMC/Volvo		392-9131	309-0973	393-0173	393-0473
027125816	GMC/Volvo		392-9131	309-0973	393-0173	393-0473
06-201	Batco	447-4743				
06-203	Batco	447-4743				
06-204	Batco	448-4836				
06-210	Batco	448-4836				
06-226	Batco	447-4723				
06-348	Batco	448-4837				
06-354	Batco	448-4836				
06-358	Batco	448-4836				
06-403	Batco	447-4743				
06-404	Batco	447-4743				
06-411	Batco	449-4973				
06-412	Batco	449-4973				
06-424	Batco	447-4743				
06-425	Batco	447-4743				
06-470	Batco	449-4974				
06-472	Batco	449-4974				
06-482	Batco	449-4973				
06-484	Batco	449-4973				
1008569	Eaton	330-3009				
100858201	Eaton		382-8036	308-0836	383-0136	383-0436
100858401	Eaton		382-8036	308-0836	383-0136	383-0436
10284	Dana	447-4743				
10284	Kershaw	447-4743				
10286	Dana	447-4743				
10286	Kershaw	447-4743				
103100-1	Std. Forge	447-4743				
103102-001	Std. Forge	447-4743				
103103-002	Std. Forge	447-4743				
103104-001	Std. Forge	447-4743				
103105	Std. Forge	448-4836				
10406	Dana	447-4743				
10408	Dana	447-4743				
105013	Std. Forge	447-4743				
10895522	GMC/Volvo			308-0870		
11249	Eaton	449-4973				
11724	Dexter	320-2110				
119427	Eaton	460-6002				
119429	Eaton	460-6006				

CROSS REFERENCE

Information contained in this section is furnished as a guide. Verify specific application elsewhere in this catalog when possible.

COMPETITIVE PART NO.	COMPETITOR'S NAME	STEMCO MISC PRODUCTS	STEMCO STD/ GRIT GUARD®	STEMCO GUARDIAN®	STEMCO VOYAGER®	DISCOVER® XR
119431	Eaton	460-6001				
119457	Eaton	460-6002				
1199J2428	Meritor		392-9087			
1199R2722	Meritor	310-1018				
1199V1296	Meritor	310-1012/1091				
1199Z3094	Meritor	315-1504				
1199Z3146	Meritor		392-9087			
1207	C/R		392-9096			
1208	C/R		392-9132			
1211	C/R		392-9131	309-0973	393-0173	393-0473
1213	C/R		392-9087			
1214	C/R		392-9099	309-0912	393-0112	
1215	C/R		392-9131	309-0973	393-0173	393-0473
1216	C/R		392-9087			
121SR19	Mack	330-3009				
1227-B-106	Meritor	448-4836				
1227-B-756	Meritor	447-4743				
1227-B-1484	Meritor	447-4723				
1227-C-549	Meritor	447-4743				
1227-E-1045	Meritor	449-4974				
1227-K-1389	Meritor	447-4723				
1227-L-194	Meritor	448-4836				
1227-M-715	Meritor	449-4974				
1227-R-330	Meritor	449-4973				
1227-R-1240	Meritor	449-4973				
1227-T-228	Meritor	447-4743				
1227-T-540	Meritor	447-4743				
1227-U-541	Meritor	448-4836				
1227-W-517	Meritor	449-4973				
1227-X-102	Meritor	448-4836				
1227-Z-1040	Meritor	449-4974				
1227-P-1160	Meritor	447-4743				
1244U879	Meritor	310-1089				
127043	Eaton	320-2106				
127719	Eaton	460-6006				
127720	Eaton	460-6001				
127721	Eaton	460-6002				
128113	Crane	330-3009				
128333	Eaton	448-4837				
1282	C/R	340-4975				
1283	C/R	640-0003				
1284	C/R	349-4975				
128355	Eaton	320-2102				
1307	C/R			309-0935		
1308	C/R		392-9099	309-0912	393-0112	
1311	C/R	349-4024				
1343	C/R	349-4009				

(Continued Next Page)

CROSS REFERENCE

Information contained in this section is furnished as a guide. Verify specific application elsewhere in this catalog when possible.

COMPETITIVE PART NO.	COMPETITOR'S NAME	STEMCO MISC PRODUCTS	STEMCO STD/ GRIT GUARD®	STEMCO GUARDIAN®	STEMCO VOYAGER®	DISCOVER® XR
13567	Crane	320-2137				
13568	Crane	320-2106				
1399	C/R	349-4195				
1436860008	Westport	343-4024				
1436860010	Westport	343-4249				
1436860011	Westport	343-4095				
1436900006	Westport		382-8036	308-0836	383-0136	383-0436
1436900007	Westport		372-7097	307-0743	373-0143	373-0443
150012	Ceromet	448-4836				
150018	Ceromet	448-4837				
15507089	GMC		382-8064	308-0864	383-0164	383-0464
15511620	GMC/Volvo	359-5970				
15519908	GMC/Volvo		382-8071		383-0171	
15527755	GMC/Volvo			308-0863		
15527780	GMC/Volvo			308-0853		
15534441	GMC/Volvo	359-5968				
1554331C1	Navistar		382-8036	308-0836	383-0136	383-0436
15550869	GMC/Volvo		392-9131	309-0973	393-0173	
15556130	GMC/Volvo	343-4249				
15556131	GMC/Volvo	330-3122				
15557677	GMC/Volvo		392-9131	309-0973	393-0173	393-0473
15557678	GMC/Volvo		392-9099	309-0912	393-0112	
15587578	GMC/Volvo	340-4263				
15587579	GMC/Volvo	340-4263				
15663537	GMC/Volvo		382-8036	308-0836	383-0136	383-0436
15679880	GMC/Volvo		392-9131	309-0973	393-0173	393-0473
15679881	GMC/Volvo		392-9099	309-0912	393-0112	
15687419	GMC/Volvo		382-8064	308-0864	383-0164	383-0464
15703555	GMC/Volvo		392-9099	309-0912	393-0112	
15844467	GMC/Volvo			308-0870		
15965962	GMC/Volvo	310-1018				
15982869	GMC/Volvo		392-9131	309-0973	393-0173	393-0473
1600	C/R	347-4009				
1607743C1	Navistar	448-4836				
1607744C1	Navistar	449-4973				
1608	C/R	340-4065				
1609948C1	Navistar	320-2106				
1611843C91	Navistar		382-8036	308-0836	383-0136	383-0436
1612	C/R	343-4024				
1612823C1	Navistar				383-0156	
1612877C91	Navistar		382-8064	308-0864	383-0164	383-0464
1613	C/R	343-4249				
1615304C1	Navistar		382-8036	308-0836	383-0136	383-0436
1615305C1	Navistar		392-9131	309-0973	393-0173	393-0473
1630	C/R	343-4014				
1642	C/R	343-4013				
1643	C/R	343-4009				

CROSS REFERENCE

Information contained in this section is furnished as a guide. Verify specific application elsewhere in this catalog when possible.

COMPETITIVE PART NO.	COMPETITOR'S NAME	STEMCO MISC PRODUCTS	STEMCO STD/ GRIT GUARD®	STEMCO GUARDIAN®	STEMCO VOYAGER®	DISCOVER® XR
1643	C/R	343-4249				
1644	C/R	343-4009				
1649628C1	Navistar		372-7097	307-0743	373-0143	373-0443
1654330C1	Navistar		392-9099	309-0912	393-0112	
1654331C1	Navistar		382-8036	308-0836	383-0136	383-0436
1655102C1	Navistar				383-0156	
1657081C91	Navistar	343-4249				
1659759C91	Navistar		382-8066	308-0866	383-0166	
1660994C1	Navistar		382-8064	308-0864	383-0164	383-0464
166437R91	Navistar		392-9099	309-0912	393-0112	
1670	C/R	343-4072				
1680802C1	Navistar		392-9131	309-0973	393-0173	393-0473
1682	C/R	343-4075				
1688203C1	Navistar		382-8036	308-0836	383-0136	383-0436
1691	C/R	340-4098				
16911843C91	Navistar		382-8036	308-0836	383-0136	383-0436
1696	C/R	343-4195				
1698	C/R	340-4080				
1698	C/R	343-4164				
1703	C/R	343-4249				
1711	C/R	343-4024				
1742	C/R	343-4013				
1743	C/R	343-4009				
1743	C/R	343-4046				
1743	C/R	343-4095				
1753	C/R	343-4249				
1754	C/R	343-4057				
1788	C/R	343-4249				
1790	C/R	343-4098				
1800	C/R	347-4009				
1803	C/R	343-4149				
1808	C/R	343-4065				
1811	C/R	343-4024				
1827	C/R	343-4002				
1842	C/R	343-4013				
1843	C/R	343-4009				
1843	C/R	343-4046				
1843	C/R	343-4095				
1890	C/R	343-4249				
19186	Eaton	447-4743				
19QJ29302A	Mack	343-4024/4308				
19QJ29304	Mack	343-4095				
19QJ29304A	Mack	343-4095/4309				
19QJ313	Mack	343-4009				
19QJ318	Mack	343-4098				
19QJ319	Mack	343-4249				
19QJ324	Mack	343-4095				

(Continued Next Page)

CROSS REFERENCE

Information contained in this section is furnished as a guide. Verify specific application elsewhere in this catalog when possible.

COMPETITIVE PART NO.	COMPETITOR'S NAME	STEMCO MISC PRODUCTS	STEMCO STD/ GRIT GUARD®	STEMCO GUARDIAN®	STEMCO VOYAGER®	DISCOVER® XR
19QJ332	Mack	343-4249				
19QJ334	Mack	343-4024				
19QJ335	Mack	343-4264				
19QJA29302	Mack	343-4024				
19QJA29304	Mack	343-4095				
19QJA310	Mack	343-4025				
19QJA310P1	Mack	343-4025				
19QJA315	Mack	343-4057				
19QJA319	Mack	343-4249				
19QJA320	Mack	343-4249				
2009947C91	Navistar	343-4281				
2029409	GMC/Volvo	320-2102				
2033466C91	Navistar	343-4065				
2033863C91	Navistar	343-4009				
203452	Manac	330-3009/3067				
203453	Manac	343-4009				
203467	Manac	315-1504				
203470	Manac	320-2110				
2037474C1	Navistar	448-4837				
2045996	GMC/Volvo				383-0101	
2056780	GMC/Volvo	359-5991				
2059246	GMC/Volvo	359-5995				
2078026	GMC/Volvo		392-9132			
2079222	GMC/Volvo	359-5990				
2099450	GMC/Volvo	320-2104				
2208A885	Meritor	330-3060				
2208C575	Meritor	330-3009				
2208C835	Meritor	330-3040				
2208E889	Meritor	330-3024				
2208N820	Meritor	330-3097				
2208U1113	Meritor	330-3118				
2245A27	Meritor	310-1089				
2297M6981	Meritor	315-1525				
2302130	GMC/Volvo	310-1123				
2317614	GMC/Volvo		392-9131	309-0973	393-0173	393-0473
240694R1	Navistar	359-6032				
2413360	GMC/Volvo		392-9053			
2455044	GMC/Volvo	330-3009				
2455093	GMC/Volvo	330-3041				
2455943	GMC/Volvo	320-2017				
2455944	GMC/Volvo	310-1017				
2456739	GMC/Volvo	310-1079				
2485338	GMC/Volvo	310-1018				
2498220	GMC/Volvo		382-8064	308-0864	383-0164	383-0464
2501559C1	Navistar	449-4974				
254032C91	Navistar		392-9053			
26209	C/R	429-0004				

CROSS REFERENCE

Information contained in this section is furnished as a guide. Verify specific application elsewhere in this catalog when possible.

COMPETITIVE PART NO.	COMPETITOR'S NAME	STEMCO MISC PRODUCTS	STEMCO STD/ GRIT GUARD®	STEMCO GUARDIAN®	STEMCO VOYAGER®	DISCOVER® XR
26220	C/R	429-0004				
26239	C/R	429-0004				
262512	Ceromet	449-4974				
262516C	Ceromet	447-4743				
26373	C/R	429-0003				
26378	C/R	460-6002				
26762	C/R	429-0004				
2708026	GMC/Volvo		392-9132			
27295	C/R	429-0008				
2757682	GMC/Volvo		392-9096			
278616C91	Navistar	320-2117				
280886C91	Navistar		392-9099	309-0912	393-0112	
283109C1	Navistar	359-5995				
283110C1	Navistar	359-5990				
283111C1	Navistar	359-5997				
283112C1	Navistar	359-5992				
283113C1	Navistar	359-5996				
283114C1	Navistar	359-5991				
28745	C/R		382-8066	308-0866	383-0166	
28758	C/R		382-8066	308-0866	383-0166	
296393C91	Navistar		382-8036	308-0836	383-0136	383-0436
296436C1	Navistar	330-3036				
296438C91	Navistar		372-7099	307-0713	373-0113	
29QJ127	Mack	310-1041				
29QJ210	Mack	310-1051				
29QJ222	Mack	315-1516				
29QJ230	Mack	310-1089				
29QJ233	Mack	310-1079				
301	NOK		372-7098	307-0713	373-0113	
301401	Pioneer Weston		372-7098	307-0713	373-0113	
302	NOK		372-7099	307-0723	373-0123	373-0423
302200	Pioneer Weston		372-7099	307-0723	373-0123	373-0423
302402	Pioneer Weston		372-7099	307-0723	373-0123	373-0423
303	NOK		372-7097	307-0743	373-0143	373-0443
303100	Pioneer Weston		372-7097	307-0743	373-0143	373-0443
303403	Pioneer Weston		372-7097	307-0743	373-0143	373-0443
304	NOK		392-9131	309-0973	393-0173	393-0473
304404	Pioneer Weston		372-7095	307-0744	373-0144	
305	NOK		382-8036	308-0836	383-0136	383-0436
305387C1	Navistar	310-1089				
305405	Pioneer Weston		392-9094	309-0903		
306	NOK		392-9099	309-0912	393-0112	
306408	Pioneer Weston		392-9087			
307408	Pioneer Weston		392-9131	309-0973	393-0173	393-0473
308	NOK		392-9132			
308408	Pioneer Weston		392-9132			
309409	Pioneer Weston		392-9099	309-0912	393-0112	

(Continued Next Page)

CROSS REFERENCE

Information contained in this section is furnished as a guide. Verify specific application elsewhere in this catalog when possible.

COMPETITIVE PART NO.	COMPETITOR'S NAME	STEMCO MISC PRODUCTS	STEMCO STD/GRIT GUARD®	STEMCO GUARDIAN®	STEMCO VOYAGER®	DISCOVER® XR
30QJ256	Mack	315-1511				
30QJ258	Mack	315-1515				
311411	Pioneer Weston		392-9096			
312100	Pioneer Weston		382-8036	308-0836	383-0136	383-0436
31244	C/R	320-2022				
31266	C/R	320-2125				
31281	C/R		372-7049			
3130997908	Bluebird		382-8036	308-0836	383-0136	383-0436
315100	Pioneer Weston		382-8064	308-0864	383-0164	383-0464
317100	Pioneer Weston				383-0156	
31927	Eaton	449-4973				
3208J1076	Meritor	330-3041				
32385	C/R	429-0007				
32397	C/R	429-0007				
32410	C/R	460-6011				
325012	Ceromet	449-4973				
32870	C/R	429-0011				
32QJ112B	Mack		392-9092			
32QJ127A	Mack		392-9131	309-0973	393-0173	393-0473
32QJ131A	Mack		382-8064	308-0864	383-0164	383-0464
32QJ179	Mack	320-2106				
32QJ228	Mack	320-2009				
32QJ235	Mack	320-2023				
32QJ237	Mack	320-2106				
32QJ240	Mack	320-2097				
32QJ241	Mack	320-2129				
32QJ243	Mack	320-2213				
32QJ245	Mack	320-2137				
32QJ248	Mack				383-0139	
32QJ249	Mack	320-2118				
32QJ251	Mack	320-2099				
32QJ252	Mack		382-8064	308-0864	383-0164	383-0464
32QJ260	Mack	320-2001				
32QJ262	Mack				383-0139	
32QJ263	Mack		392-9094	309-0903	393-0103	
32QJ267	Mack		392-9131	309-0973	393-0173	393-0473
32QJ268	Mack		392-9094	309-0903	393-0103	
32QJ269	Mack		382-8036	308-0836	383-0136	383-0436
32QJ270	Mack		382-8064	308-0864	383-0164	383-0464
32QJ271	Mack		392-9112	309-0904	393-0104	
32QJ276	Mack		392-9089	309-0948	393-0148	
32QJ29315	Mack		382-8036	308-0836	383-0136	383-0436
32QJ29316	Mack		392-9131	309-0973	393-0173	393-0473
32QJ29318	Mack		392-9094	309-0904	393-0104	
32QJ29320	Mack		382-8064	308-0864	383-0164	383-0464
330783408	Western Star		392-9131	309-0973	393-0173	393-0473
331471C91	Navistar	320-2102				

CROSS REFERENCE

Information contained in this section is furnished as a guide. Verify specific application elsewhere in this catalog when possible.

COMPETITIVE PART NO.	COMPETITOR'S NAME	STEMCO MISC PRODUCTS	STEMCO STD/GRIT GUARD®	STEMCO GUARDIAN®	STEMCO VOYAGER®	DISCOVER® XR
33254	C/R	429-0011				
33751	C/R	429-0014				
337711C92	Navistar		392-9099	309-0912	393-0112	
338877R91	Navistar		392-9036			
34090	Eaton	447-4743				
340929C91	Navistar		392-9036			
3415R38	Mack	310-1007				
34383	C/R			309-0935		
34384	C/R PlusXL			309-0935		
34385	C/R			309-0935		
34386	C/R			309-0935		
34387	C/R Classic			309-0935		
348012	Ceromet	447-4723				
348012E	Ceromet	447-4724				
34882	C/R	429-0002				
34885	C/R			308-0863		
34891	C/R	429-0002				
34971	C/R PlusXL			308-0863		
34972	C/R			308-0863		
34975	C/R Classic			308-0863		
34980	C/R			308-0863		
34994	C/R PlusXL		392-9036			
34999	C/R		392-9036			
35000	C/R Classic		392-9036			
35001	C/R LongLife		392-9036			
35012	C/R		392-9036			
35029	C/R		392-9036			
35058	C/R PlusXL		382-8036	308-0836	383-0136	383-0436
35059	C/R		382-8036	308-0836	383-0136	383-0436
35060	C/R		382-8035			
35062	C/R		382-8036	308-0836	383-0136	383-0436
35066	C/R Classic		382-8036	308-0836	383-0136	383-0436
35072	C/R	<i>Same as 35066 used for worn hubs or oversize seal bore</i>				
35075	C/R		372-7006			
35093	C/R		372-7006			
35102	C/R		382-8036	308-0836	383-0136	383-0436
35103	C/R LongLife		382-8036	308-0836	383-0136	383-0436
357	National	330-3077				
35810	C/R			309-0935		
359922C91	Navistar		382-8064	308-0864	383-0164	383-0464
36314	C/R		392-9037			
36357	C/R		382-8071		383-0171	
36358	C/R Classic		382-8071		383-0171	
36365	C/R Classic		382-8071		383-0171	
36378	C/R		372-7006			
364SZ100	Mack		382-8036	308-0836	383-0136	383-0436
364SZ202	Mack		392-9131	309-0973	393-0173	393-0473

(Continued Next Page)

CROSS REFERENCE

Information contained in this section is furnished as a guide. Verify specific application elsewhere in this catalog when possible.

COMPETITIVE PART NO.	COMPETITOR'S NAME	STEMCO MISC PRODUCTS	STEMCO STD/GRIT GUARD®	STEMCO GUARDIAN®	STEMCO VOYAGER®	DISCOVER® XR
3645Z206	Mack		382-8036	308-0836	383-0136	383-0436
36506	Eaton		392-9099	309-0912	393-0112	
370001A	National		382-8036	308-0836	383-0136	383-0436
370002A	National		372-7006			
370003A	National		392-9131	309-0973	393-0173	393-0473
370004A	National		392-9001			
370005A	National		392-9132			
370006A	National		392-9087			
370011A	National		382-8071		383-0171	
370014A	National		372-7049			
370019A	National		392-9092			
370022A	National		392-9094	309-0903	393-0103	
370023A	National		392-9099	309-0912	393-0112	
370024A	National		392-9099			
370025A	National		372-7097	307-0743	373-0143	373-0443
370026A	National		372-7022			
370031A	National		392-9112	309-0904	393-0104	
370033A	National				383-0139	
370034A	National		392-9131	309-0973	393-0173	393-0473
370036A	National		372-7098	307-0713	373-0113	
370037A	National		372-7095	307-0744	373-0144	
370047A	National			309-0935		
370048A	National		382-8064	308-0864	383-0164	383-0464
370065A	National		372-7099	307-0723	373-0123	373-0423
370120A	National		392-9053			
370124A	National			308-0853		
370132A	National			308-0863		
370150A	National		382-8066	308-0866	383-0166	
370165A	National		392-9099	309-0912/0915		
370169A	National		392-9036			
370181A	National		392-9132			
370182A	National		382-8064	308-0864	383-0164	383-0464
370192A	National		372-7015			
370195A	National				393-0134	
370198A	National				383-0139	
370338A	National		372-7095	307-0744	373-0144	
370349A	National		372-7098	307-0713	373-0113	
376590A	National		372-7099	307-0723	373-0123	373-0423
380001A	National		382-8036	308-0836	383-0136	383-0436
380003A	National		392-9131	309-0973	393-0173	393-0473
380019C91	Navistar		392-9099	309-0912	393-0112	
380022A	National		392-9094	309-0903	393-0103	
380023A	National		392-9099	309-0912	393-0112	
380025A	National		372-7097	307-0743	373-0143	373-0443
380031A	National		392-9112 ¹	309-0904	393-0104	
380036A	National		372-7098	307-0713	373-0113	
380048A	National		382-8064	308-0864	383-0164	383-0464

¹ When using HM516449A, use 392-9130 set.

CROSS REFERENCE

Information contained in this section is furnished as a guide. Verify specific application elsewhere in this catalog when possible.

COMPETITIVE PART NO.	COMPETITOR'S NAME	STEMCO MISC PRODUCTS	STEMCO STD/GRIT GUARD®	STEMCO GUARDIAN®	STEMCO VOYAGER®	DISCOVER® XR
380065A	National		372-7099	307-0723	373-0123	373-0423
380131A	National				383-0156	
3827712	Dodge			308-0863		
383706C91	Navistar		392-9001			
383727C1	Navistar	330-3040				
383728C1	Navistar	330-3056				
383733C1	Navistar	330-3001				
386590A	National		372-7099	307-0723	373-0123	373-0423
38745	C/R		392-9099	309-0912	393-0112	
38747	C/R		392-9099	309-0912	393-0112	
38748	C/R		392-9099			
38750	C/R Classic		392-9099			
38774	C/R		392-9099	309-0912	393-0112	
38776	C/R PlusXL		392-9099	309-0912	393-0112	
38777	C/R		392-9099	309-0912	393-0112	
38778	C/R		392-9099	309-0912	393-0112	
38779	C/R		392-9099	309-0912	393-0112	
38780	C/R Classic		392-9099	309-0912	393-0112	
38782	C/R		392-9099	309-0912	393-0112	
38783	C/R LongLife		392-9099	309-0912	393-0112	
388250C91	Navistar	343-4025				
39380	C/R		382-8029			
39381	C/R				383-0139	
3941956	Volvo		392-9131	309-0973	393-0173	393-0473
3942006	Volvo		382-8036	308-0836	383-0136	383-0436
39426	C/R		308-0870	308-0870		
39448886	GMC/Volvo	320-2050				
3948884	GMC/Volvo	310-1052				
394894C91	Navistar		382-8036	308-0836	383-0136	383-0436
396526C91	Navistar		392-9096			
398124C1	Navistar	310-1089				
39975	C/R				383-0139	
39977	C/R				383-0139	
39979	C/R PlusXL				383-0139	
39980	C/R				383-0139	
39981	C/R				383-0139	
39988	C/R Classic				383-0139	
39990	C/R				383-0139	
3W5687	Caterpillar	343-4009				
3W6998	Caterpillar	330-3009				
4000531R91	Navistar	460-6011				
40049	C/R				383-0139	
40051	C/R				383-0139	
40052	C/R				383-0139	
40077	C/R				383-0101	
40078	C/R				383-0101	
40080	C/R				383-0101	

(Continued Next Page)

CROSS REFERENCE

Information contained in this section is furnished as a guide. Verify specific application elsewhere in this catalog when possible.

COMPETITIVE PART NO.	COMPETITOR'S NAME	STEMCO MISC PRODUCTS	STEMCO STD/GRIT GUARD®	STEMCO GUARDIAN®	STEMCO VOYAGER®	DISCOVER® XR
40082	C/R				383-0101	
40086	C/R Classic				383-0101	
40088	C/R				383-0101	
40090	C/R LongLife				383-0101	
40091	C/R PlusXL				383-0101	
401265	Mechanex/Barrier	330-3077				
40129	C/R PlusXL		372-7098	307-0713	373-0113	
40130	C/R		372-7098	307-0713	373-0113	
40133	C/R		372-7098	307-0713	373-0113	
40136	C/R Classic		372-7098	307-0713	373-0113	
40146	C/R		372-7098	307-0713	373-0113	
40147	C/R LongLife		372-7098	307-0713	373-0113	
401503	Mechanex/Barrier	330-3002				
401504	Mechanex/Barrier	330-3024				
401507	Mechanex/Barrier	330-3041				
401508	Mechanex/Barrier	330-3120				
401510	Mechanex/Barrier	330-3041				
401511	Mechanex/Barrier	330-3060				
401514	Mechanex/Barrier	330-3034				
401516	Mechanex/Barrier	330-3025				
401516	Mechanex/Barrier	330-3035				
401519	Mechanex/Barrier	330-3012				
401524	Mechanex/Barrier	330-3097				
401524	Mechanex/Barrier	330-3122				
401911P	Mechanex/Barrier	340-4975				
40210	C/R		392-9099	309-0912	393-0112	
40360	C/R		392-9099	309-0912	393-0112	
405367C91	Navistar	460-6004				
411601P	Midland	343-4009				
411604P	Midland	343-4008				
411605P	Midland	343-4095				
411605P	Midland	343-4098				
411605P	Midland	343-4249				
411608P	Midland	343-4013				
411625P	Midland	343-4018				
411630P	Midland	343-4024				
411635P	Midland	343-4065				
411646P	Midland	343-4025				
411655P	Midland	343-4075				
411688P	Midland	343-4095				
411845P	Midland	343-4149				
411917P	Midland	340-4119				
411967P	Midland	343-4046				
4131005	Trailmobile	330-3009				
4131008	Trailmobile	330-3013				
4131012	Trailmobile	330-3019				
4131013	Trailmobile	330-3024				

CROSS REFERENCE

Information contained in this section is furnished as a guide. Verify specific application elsewhere in this catalog when possible.

COMPETITIVE PART NO.	COMPETITOR'S NAME	STEMCO MISC PRODUCTS	STEMCO STD/GRIT GUARD®	STEMCO GUARDIAN®	STEMCO VOYAGER®	DISCOVER® XR
4131018	Trailmobile	330-3077				
4131024	Trailmobile	330-3104				
4131025	Trailmobile	330-3067				
4131026	Trailmobile	330-3118				
4131027	Trailmobile	330-3122				
4131056	Trailmobile	330-3056				
4131096	Trailmobile	343-4095				
4131097	Trailmobile	343-4195				
4131100	Trailmobile	343-4009				
4131103	Trailmobile	343-4013				
4131115	Trailmobile	343-4075				
4131122	Trailmobile	359-5981				
4131123	Trailmobile	359-5990				
4131124	Trailmobile	343-4249				
4131128	Trailmobile	343-4009				
4131135	Trailmobile		372-7098	307-0713	373-0113	
4131144	Trailmobile		372-7099	307-0723	373-0123	373-0423
4131145	Trailmobile		372-7091			
4131150	Trailmobile		372-7097	307-0743	373-0143	373-0443
4131151	Trailmobile		372-7095	307-0744	373-0144	
4131159	Trailmobile		372-7091			
4131160	Trailmobile		372-7095	307-0744	373-0144	
4131162	Trailmobile		372-7097	307-0743	373-0143	373-0443
4131163	Trailmobile		372-7098	307-0713	373-0113	
4131164	Trailmobile		372-7099	307-0723	373-0123	373-0423
4131167	Trailmobile		392-9132			
4131169	Trailmobile		392-9132			
4131170	Trailmobile		392-9131	309-0973	393-0173	393-0473
4131171	Trailmobile		392-9131	309-0973	393-0173	393-0473
4131173	Trailmobile		392-9099	309-0912	393-0112	
4131188	Trailmobile		392-9087			
4131189	Trailmobile		392-9087			
4131191	Trailmobile		392-9012	309-0912	393-0112	
4131192	Trailmobile		392-9099	309-0912	393-0112	
4131194	Trailmobile		392-9094	309-0903		
4131197	Trailmobile		392-9112	309-0904		
4131204	Trailmobile		382-8064	308-0864		
4131210	Trailmobile		372-7098	307-0713	373-0113	
4131211	Trailmobile		372-7099	307-0723	373-0123	373-0423
4131212	Trailmobile		372-7097	307-0743	373-0143	373-0443
4131213	Trailmobile		372-7095	307-0744	373-0144	
4131214	Trailmobile		382-8036	308-0836	383-0136	383-0436
4131215	Trailmobile				383-0156	
4131216	Trailmobile		382-8064	308-0864	383-0164	383-0464
4131220	Trailmobile		382-8036	308-0836	383-0136	383-0436
4131224	Trailmobile		392-9087			
4131225	Trailmobile		392-9112	309-0904	393-0104	

(Continued Next Page)

CROSS REFERENCE

Information contained in this section is furnished as a guide. Verify specific application elsewhere in this catalog when possible.

COMPETITIVE PART NO.	COMPETITOR'S NAME	STEMCO MISC PRODUCTS	STEMCO STD/GRIT GUARD®	STEMCO GUARDIAN®	STEMCO VOYAGER®	DISCOVER® XR
4131226	Trailmobile		392-9131	309-0973	393-0173	393-0473
4131227	Trailmobile		392-9132			
4131229	Trailmobile		392-9112	309-0904	393-0104	
4131230	Trailmobile		392-9132			
4131231	Trailmobile		392-9131	309-0973	393-0173	393-0473
4131234	Trailmobile		372-7098	307-0713	373-0113	
4131235	Trailmobile		372-7097	307-0743	373-0143	373-0443
4131236	Trailmobile		372-7099	307-0723	373-0123	373-0423
4131243	Trailmobile	359-5915				
4131244	Trailmobile	359-5995				
4131249	Trailmobile		382-8036	308-0836	383-0136	383-0436
4131250	Trailmobile				383-0156	
4131251	Trailmobile		382-8064	308-0864	383-0164	383-0464
414467C91	Navistar		372-7095	307-0744	373-0144	
414467C93	Navistar	320-2118				
415058	National		392-9112	309-0904	393-0104	
415060	National		392-9096			
415371	National		392-9094	309-0903	393-0103	
416125	National		382-8071			
417158	National		382-8066	308-0866	383-0166	
417505	National		392-9099	309-0912	393-0112	
417530	National			308-0853		
417531	National				383-0156	
42478	Great Dane		372-7097	307-0743	373-0143	373-0443
42525	Great Dane		372-7099	307-0723	373-0123	373-0423
42622	C/R		372-7062			
42622	C/R		372-7099	307-0723	373-0123	373-0423
42623	C/R		372-7062			
42623	C/R Classic		372-7099	307-0723	373-0123	373-0423
42624	C/R		372-7091			
42625	C/R	Same as 42623 used for worn hubs or oversize seal bore				
42627	C/R PlusXL		372-7099	307-0723	373-0123	373-0423
42630	C/R		372-7099	307-0723	373-0113	
42631	C/R LongLife		372-7099	307-0723	373-0123	373-0423
42644	C/R		392-9112	309-0904	393-0104	
42650	C/R		392-9112	309-0904	393-0104	
42671	C/R		392-9112	309-0904	393-0104	
42672	C/R Classic		392-9112	309-0904	393-0104	
42673	C/R PlusXL		392-9112	309-0904	393-0104	
426834C1	Navistar	343-4065				
428119C91	Navistar	320-2102				
428455C91	Navistar	320-2106				
431616R92	Navistar	320-2113				
431619R91	Navistar		372-7098	307-0713	373-0113	373-0423
431620R91	Navistar	343-4009				
431620R92	Navistar	343-4009				
431621R2	Navistar	330-3009/3067				

CROSS REFERENCE

Information contained in this section is furnished as a guide. Verify specific application elsewhere in this catalog when possible.

COMPETITIVE PART NO.	COMPETITOR'S NAME	STEMCO MISC PRODUCTS	STEMCO STD/GRIT GUARD®	STEMCO GUARDIAN®	STEMCO VOYAGER®	DISCOVER® XR
431622R1	Navistar	320-2109				
43751	C/R		372-7095	307-0744	373-0144	
43752	C/R Classic		372-7095	307-0744	373-0144	
43753	C/R		372-7095	307-0744	373-0144	
43754	C/R PlusXL		372-7095	307-0744	373-0144	
43760	C/R		382-8064	308-0864	383-0164	383-0464
43761	C/R PlusXL		382-8064	308-0864	383-0164	383-0464
43762	C/R		382-8064	308-0864	383-0164	383-0464
43763	C/R		382-8064	308-0864	383-0164	383-0464
43764	C/R Classic		382-8064	308-0864	383-0164	383-0464
43820	C/R		392-9092			
43820	C/R		392-9096			
43860	C/R Classic		392-9096			
43861	C/R		392-9096			
43865	C/R		392-9092			
43875	C/R		392-9131	309-0973	393-0173	393-0473
44068	Great Dane	343-4009				
447551C91	Navistar		392-9131	309-0973	393-0173	393-0473
447551C92	Navistar	310-1013				
447556C91	Navistar			308-0853		
447561C91	Navistar		382-8036	308-0836	383-0136	383-0436
447562C91	Navistar		382-8064	308-0864	383-0164	383-0464
447563C91	Navistar		392-9001			
447563C92	Navistar	320-2001				
447564C92	Navistar	320-2113				
447567C92	Navistar	320-2117				
447569C91	Navistar		392-9096			
447569C92	Navistar		392-9096			
447574C91	Navistar		392-9131	309-0973	393-0173	393-0473
447574C92	Navistar		392-9131	309-0973	393-0173	393-0473
44916	C/R PlusXL			308-0853		
44919	C/R			308-0853		
44920	C/R			308-0853		
44922	C/R Classic			308-0853		
450023	C/R	330-3109				
450155	C/R	330-3106				
450293	C/R	330-3122				
450358	National	460-6004				
450409	C/R	310-1057				
45066	C/R		392-9094	309-0903	393-0103	
45069	C/R		392-9094	309-0903	393-0103	
45070	C/R		392-9094	309-0903	393-0103	
450741	C/R	330-3025				
450742	C/R	330-3012				
450743	C/R	330-3042				
450744	C/R	330-3056				
450747	C/R	330-3007				

(Continued Next Page)

CROSS REFERENCE

Information contained in this section is furnished as a guide. Verify specific application elsewhere in this catalog when possible.

COMPETITIVE PART NO.	COMPETITOR'S NAME	STEMCO MISC PRODUCTS	STEMCO STD/ GRIT GUARD®	STEMCO GUARDIAN®	STEMCO VOYAGER®	DISCOVER® XR
450748	C/R	330-3041				
450751	C/R	330-3009/3067				
450752	C/R	330-3060				
450755	C/R	330-3024				
450757	C/R	330-3037				
450760	C/R	330-3008				
450762	C/R	330-3062				
450765	C/R	330-3040				
450767	C/R	330-3015				
450768	C/R	330-3034				
450769	C/R	330-3011				
450775	C/R	330-3013				
450777	C/R	330-3019				
450778	C/R	330-3031				
450781	C/R	330-3097				
450788	C/R	330-3122/3067				
450875	C/R	330-3105				
450876	C/R	330-3106				
450877	C/R	330-3107				
450878	C/R	330-3108				
450879	C/R	330-3109				
45093	C/R PlusXL		392-9094	309-0903	393-0103	
45095					383-0156	
45097	C/R		392-9094	309-0903	393-0103	
45098	C/R		392-9094	309-0903	393-0103	
450980	C/R	330-3110				
450981	C/R	330-3111				
450982	C/R	330-3112				
450983	C/R	330-3113				
450984	C/R	330-3114				
450985	C/R	330-3115				
45099	C/R Classic		392-9094	309-0903	393-0103	
45102	C/R				383-0156	
45103	C/R Classic				383-0156	
45108	C/R		392-9094	309-0903	393-0103	
45152	C/R		392-9131	309-0973	393-0173	
453027C1	Navistar		392-9001			
453644	C/R	330-3122/3067				
453645	C/R	330-3025				
453646	C/R	330-3105				
4543V	National	460-6011				
455001	C/R	310-1050				
455023	C/R	357-5706				
455034	C/R	310-1041				
455037	C/R	310-1051				
455052	C/R	310-1051				
455058	National		392-9112	309-0904	393-0104	

CROSS REFERENCE

Information contained in this section is furnished as a guide. Verify specific application elsewhere in this catalog when possible.

COMPETITIVE PART NO.	COMPETITOR'S NAME	STEMCO MISC PRODUCTS	STEMCO STD/ GRIT GUARD®	STEMCO GUARDIAN®	STEMCO VOYAGER®	DISCOVER® XR
455060	National		392-9096			
455068	National		392-9019			
455173	National		392-9036			
455188	National				383-0139	
455211	National		372-7097	307-0743	373-0143	373-0443
455355	National		382-8066	308-0866	383-0166	
455858	National			309-0935		
455958	National		392-9099	309-0912	393-0112	
4563V	National	460-6003				
456618	National		392-9099	309-0912	393-0112	
45742	Great Dane	330-3009				
45951	Great Dane	320-2110				
45952	Great Dane	315-1504				
46200	C/R		392-9094	309-0903	393-0103	
46211	C/R		392-9094	309-0903	393-0103	
46300	C/R PlusXL		372-7097	307-0743	373-0143	373-0443
46304	C/R		372-7097	307-0743	373-0143	373-0443
46305	C/R Classic		372-7097	307-0743	373-0143	373-0443
46306	C/R		372-7097	307-0743	373-0143	373-0443
46308	C/R LongLife		372-7097	307-0743	373-0143	373-0443
46390	C/R		372-7022			
46390	C/R		372-7099	307-0723	373-0123	373-0423
465510C91	Navistar	320-2164				
46841	Victor		372-7099	307-0723	373-0123	373-0423
469844C1	Navistar		382-8066	308-0866	383-0166	
469845C1	Navistar		392-9036			
47017	Great Dane	347-4009				
472HH101	Dana	460-6007				
47394	C/R		372-7098	307-0713	373-0113	
47483	C/R		392-9066			
47548	Great Dane	343-4195				
47549	Great Dane	343-4009				
47550	Great Dane	343-4075				
47555	Great Dane		372-7099	307-0723	373-0123	373-0423
47556	Great Dane		372-7097	307-0743	373-0113	
47690	C/R		392-9132			
47691/47692	C/R PlusXL		392-9131	309-0973	393-0173	393-0473
47693	C/R LongLife		392-9131	309-0973	393-0173	393-0473
47694	C/R	<i>Narrow version of 47695 for ABS</i>				
47695	C/R		392-9131	309-0973	393-0173	393-0473
47696	C/R		392-9131	309-0973	393-0173	393-0473
47697	C/R Classic		392-9131	309-0973	393-0173	393-0473
47698	C/R	<i>Same as 47697 used for worn hubs or oversize seal bore</i>				
47699	C/R		392-9087			
47802	Victor		392-9096			
47803	Victor		392-9132			
48000	C/R Classic		392-9132			

(Continued Next Page)

CROSS REFERENCE

Information contained in this section is furnished as a guide. Verify specific application elsewhere in this catalog when possible.

COMPETITIVE PART NO.	COMPETITOR'S NAME	STEMCO MISC PRODUCTS	STEMCO STD/GRIT GUARD®	STEMCO GUARDIAN®	STEMCO VOYAGER®	DISCOVER® XR
48001	C/R		392-9132			
48086	Victor		372-7097	307-0743	373-0143	373-0443
48088	Victor		372-7098	307-0713	373-0113	
48089	Victor		392-9131	309-0973	393-0173	393-0473
48090	Victor		382-8036	308-0836	383-0136	383-0436
48091	Victor		392-9099	309-0912	393-0112	
48095	Victor		392-9094	309-0903	393-0103	
48096	Victor			309-0935		
48097	Victor				383-0156	
48098	Victor		392-9112	309-0904	393-0104	
48298	C/R	320-2001 w/310-1021				
48690	C/R Classic				393-0134	
48691	C/R				393-0134	
48693	C/R				393-0134	
48700	C/R				393-0134	
48701	C/R				393-0134	
4874N	National	460-6004				
48844	C/R		392-9001			
48882	C/R		392-9132			
48884	C/R		392-9001			
49050	C/R		392-9131	309-0973	393-0173	393-0473
490577C92	Navistar				383-0156	
490578C91	Navistar	320-2181				
500200C91	Navistar	320-2199				
5010196	Trailmobile	320-2110				
5010198	Trailmobile	315-1504				
50148	C/R	320-2001				
50150	C/R	320-2001				
504081	C/R		392-9094	309-0903	393-0103	
506085	Eaton	343-4024				
506089	Eaton	343-4249				
506161	Eaton	330-3024				
50640	C/R		392-9131	309-0973	393-0173	393-0473
506775	Eaton		382-8064	308-0864	383-0164	383-0464
507842C91	Navistar	320-2199				
507844C91	Navistar	320-2164				
512657C1	Navistar	320-2110				
52658	C/R		392-9089	309-0948	393-0148	
52660	C/R		392-9089	309-0948	393-0148	
52664	C/R		392-9089	309-0948	393-0148	
530088	Fruehauf	448-4836				
530480	Fruehauf		372-7099	307-0723	373-0123	373-0423
54395	C/R		392-9001			
54533HA	Navistar		392-9036			
5473	National		392-9001			
547915C91	Navistar		392-9099	309-0912	393-0112	
5481	National		392-9131	309-0973	393-0173	393-0473

CROSS REFERENCE

Information contained in this section is furnished as a guide. Verify specific application elsewhere in this catalog when possible.

COMPETITIVE PART NO.	COMPETITOR'S NAME	STEMCO MISC PRODUCTS	STEMCO STD/GRIT GUARD®	STEMCO GUARDIAN®	STEMCO VOYAGER®	DISCOVER® XR
548347C91	Navistar		392-9131	309-0973	393-0173	393-0473
548347C92	Navistar		392-9131	309-0973	393-0173	393-0473
54935	C/R		392-9001			
5495	National		392-9087			
55175	C/R		392-9053			
55177	C/R		392-9053			
5667	National		392-9099			
578913C1	Navistar	320-2041				
587989C91	Navistar				383-0156	
589822C91	Navistar			308-0853		
591587C1	Navistar			308-0855		
594962C1	Navistar		392-9131	309-0973	393-0173	393-0473
594963C1	Navistar		392-9099	309-0912	393-0112	
594964C1	Navistar		382-8064	308-0864	383-0164	383-0464
594965C1	Navistar		382-8066	308-0866	383-0166	
594966C1	Navistar			308-0853		
596555C1	Navistar		382-8036	308-0836	383-0136	383-0436
596556C1	Navistar		392-9001			
60501012	Trailmobile		372-7097	307-0743	373-0143	373-0443
61001G	TriSeal	330-3001				
61002G	TriSeal	330-3019				
61006G	TriSeal	330-3006				
61009G	TriSeal	330-3009				
61011G	TriSeal	330-3011				
61012G	TriSeal	330-3012				
61015G	TriSeal	330-3015				
61017G	TriSeal	330-3017				
61022G	TriSeal	330-3022				
61024G	TriSeal	330-3024				
61025G	TriSeal	330-3025				
61027G	TriSeal	330-3102				
61031G	TriSeal	330-3031				
61032G	TriSeal	330-3032				
61034G	TriSeal	330-3034				
61036G	TriSeal	330-3036				
61037G	TriSeal	330-3037				
61039G	TriSeal	330-3039				
61040G	TriSeal	330-3040				
61041G	TriSeal	330-3041				
61042G	TriSeal	330-3042				
61044G	TriSeal	330-3044				
61045G	TriSeal	330-3045				
61046G	TriSeal	330-3046				
61054G	TriSeal	330-3054				
61056G	TriSeal	330-3056				
61060G	TriSeal	330-3060				
61062G	TriSeal	330-3062				

(Continued Next Page)

CROSS REFERENCE

Information contained in this section is furnished as a guide. Verify specific application elsewhere in this catalog when possible.

COMPETITIVE PART NO.	COMPETITOR'S NAME	STEMCO MISC PRODUCTS	STEMCO STD/ GRIT GUARD®	STEMCO GUARDIAN®	STEMCO VOYAGER®	DISCOVER® XR
61066G	TriSeal	330-3066				
61067G	TriSeal	330-3067				
61077G	TriSeal	330-3077				
61079G	TriSeal	330-3079				
61080G	TriSeal	330-3080				
61090G	TriSeal	330-3090				
61094G	TriSeal	330-3094				
61105G	TriSeal	330-3105				
61106G	TriSeal	330-3106				
61107G	TriSeal	330-3107				
61108G	TriSeal	330-3108				
61109G	TriSeal	330-3109				
61111G	TriSeal	330-3111				
61112G	TriSeal	330-3112				
61113G	TriSeal	330-3113				
61114G	TriSeal	330-3114				
63005	TriSeal	310-1005				
63007	TriSeal	310-1007				
63009	TriSeal	310-1009				
63013	TriSeal	310-1013				
63017	TriSeal	310-1017				
63018	TriSeal	310-1018				
63041	TriSeal	310-1041				
63050	TriSeal		310-1050			
63051	TriSeal		310-1051			
63052	TriSeal		310-1052			
63053	TriSeal		310-1053			
63057	TriSeal		310-1057			
63062	TriSeal		310-1062			
63063	TriSeal		310-1063			
63064	TriSeal		310-1064			
63079	TriSeal		310-1079			
63H13	Crane	343-4264				
63H16	Crane	343-4095				
63H7	Crane	343-4009				
64006	TriSeal	343-4006				
64009	TriSeal	343-4009				
64009H	TriSeal	347-4009				
64013	TriSeal	343-4013				
64024	TriSeal	343-4024				
64025	TriSeal	343-4025				
64046	TriSeal	343-4046				
64046	TriSeal	343-4095				
64046	TriSeal	343-4249				
64065	TriSeal	343-4065				
64075A	TriSeal	343-4075				
64075G	TriSeal	342-4075				

CROSS REFERENCE

Information contained in this section is furnished as a guide. Verify specific application elsewhere in this catalog when possible.

COMPETITIVE PART NO.	COMPETITOR'S NAME	STEMCO MISC PRODUCTS	STEMCO STD/ GRIT GUARD®	STEMCO GUARDIAN®	STEMCO VOYAGER®	DISCOVER® XR
64075P	TriSeal	340-4975				
64098	TriSeal	343-4098				
64249	TriSeal	343-4249				
64656	Eaton	460-6006				
64999	TriSeal	359-5990				
65000U	TriSeal				308-0853	
65000W	TriSeal				308-0853	
65011W	TriSeal				309-0935	
65011W	TriSeal		392-9036			
65024U	TriSeal		392-9099			
65030U	TriSeal		392-9089	309-0948	393-0148	
65030W	TriSeal		392-9089	309-0948	393-0148	
65052W	TriSeal		392-9099	309-0912	393-0112	
65056U	TriSeal		392-9131	309-0973	393-0173	393-0473
65056W	TriSeal		392-9131	309-0973	393-0173	393-0473
65060U	TriSeal		372-7097	307-0743	373-0143	373-0443
65060W	TriSeal		372-7097	307-0743	373-0143	373-0443
65065W	TriSeal		392-9132			
65071U	TriSeal		392-9112	309-0904	393-0104	
65071U	TriSeal		392-9130	309-0904	393-0104	
65071W	TriSeal		392-9112	309-0904	393-0104	
65078U	TriSeal				383-0156	
65078W	TriSeal				383-0156	
65092U	TriSeal		382-8064	308-0864	383-0164	383-0464
65092W	TriSeal		382-8064	308-0864	383-0164	383-0464
65111U	TriSeal			309-0935		
65152U	TriSeal		392-9099	309-0912	393-0112	
65156U	TriSeal		392-9131	309-0973	393-0173	393-0473
65165U	TriSeal		392-9132			
65184U	TriSeal		392-9096			
65261U	TriSeal		372-7098	307-0713	373-0113	
65261W	TriSeal		372-7098	307-0713	373-0113	
65262U	TriSeal		372-7099	307-0723	373-0123	373-0423
65262W	TriSeal		372-7022			
65262W	TriSeal		372-7099	307-0723	373-0123	373-0423
65263U	TriSeal		382-8036	308-0836	383-0136	383-0436
65263W	TriSeal		382-8036	308-0836	383-0136	383-0436
65267	TriSeal		382-8029			
65269W	TriSeal		392-9001			
65270U	TriSeal		392-9094	309-0903	393-0103	
65270W	TriSeal		392-9094	309-0903	393-0103	
65272W	TriSeal		392-9094	309-0903	393-0103	
65276	TriSeal		392-9099	309-0912	393-0112	
65283U	TriSeal		392-9087			
65283W	TriSeal		392-9087			
65285W	TriSeal		392-9092			
65298U	TriSeal			307-0744	373-0144	

(Continued Next Page)

CROSS REFERENCE

Information contained in this section is furnished as a guide. Verify specific application elsewhere in this catalog when possible.

COMPETITIVE PART NO.	COMPETITOR'S NAME	STEMCO MISC PRODUCTS	STEMCO STD/ GRIT GUARD®	STEMCO GUARDIAN®	STEMCO VOYAGER®	DISCOVER® XR
65298W	TriSeal			307-0744	373-0144	
65299	TriSeal		372-7015			
6638S	National		382-8036	308-0836	383-0136	383-0436
67006	TriSeal	356-5606				
67013	TriSeal	310-1013				
680272R92	Navistar	343-4046				
680272R92	Navistar	343-4249				
6804010425	Freightliner	343-4281				
68048	TriSeal	315-1504				
68088	TriSeal	315-1515				
6809970049	Freightliner	330-3040				
681365R2	Navistar	310-1079				
6814010225	Freightliner	343-4095				
6819970046	Mercedes		392-9099	309-0912	393-0112	
6819970046	Freightliner		392-9099	309-0912	393-0112	
6819970446	Freightliner		382-8036	308-0836	383-0136	383-0436
6819970546	Freightliner		392-9131	309-0973	393-0173	393-0473
68380	Eaton		392-9096			
685215	GMC/Volvo	320-2106				
685216	GMC/Volvo	320-2106				
6872S	National		392-9131	309-0973	393-0173	393-0473
6873S	National		392-9001			
69307R91	Navistar			309-0935		
69502	TriSeal	320-2041				
69510	TriSeal		372-7098	307-0713	373-0113	
69512	TriSeal		372-7015			
69520	TriSeal		372-7099	307-0723	373-0123	373-0423
69539	TriSeal		372-7049			
69594	TriSeal		372-7022			
69596	TriSeal		372-7099	307-0723	373-0123	373-0423
69597	TriSeal		372-7098	307-0713	373-0113	
69598	TriSeal		372-7097	307-0743	373-0143	373-0443
69599	TriSeal		372-7095	307-0744	373-0144	
69697	TriSeal		382-8064	308-0864	383-0164	383-0464
69699	TriSeal		382-8036	308-0836	383-0136	383-0436
69706	TriSeal		392-9099	309-0912	393-0112	
69780	TriSeal		392-9019			
69781	TriSeal		392-9089	309-0948	393-0148	
69783	TriSeal		392-9001			
69785	TriSeal			309-0935		
69786	TriSeal		392-9036			
69788	TriSeal		392-9112	309-0904	393-0104	
69789	TriSeal		392-9087			
69792	TriSeal		392-9092			
69794	TriSeal		392-9099	309-0912	393-0112	
69797	TriSeal		392-9096			
69798	TriSeal		392-9132			

CROSS REFERENCE

Information contained in this section is furnished as a guide. Verify specific application elsewhere in this catalog when possible.

COMPETITIVE PART NO.	COMPETITOR'S NAME	STEMCO MISC PRODUCTS	STEMCO STD/ GRIT GUARD®	STEMCO GUARDIAN®	STEMCO VOYAGER®	DISCOVER® XR
69799	TriSeal		392-9131	309-0973	393-0173	393-0473
698764R1	Navistar		372-7098	307-0713	373-0113	
70012600E	Trailmobile	343-4009				
700126CD	Trailmobile	343-4013				
7003942	Western Star	343-4249				
7006S	National		392-9087			
701679	GMC/Volvo	320-2115				
7023479	Meritor	343-4095				
705400P	Mechanex/Barrier		382-8036	308-0836	383-0136	383-0436
70596	TriSeal		372-7099	307-0723	373-0123	373-0423
70597	TriSeal		372-7098	307-0713	373-0113	
70598	TriSeal		372-7097	307-0743	373-0143	373-0443
70599	TriSeal		372-7095	307-0744	373-0144	
7074450	Western Star	320-2106				
70781	TriSeal		392-9089	309-0948	393-0148	
70788	TriSeal		392-9112	309-0904	393-0104	
70789	TriSeal		392-9087			
70794	TriSeal		392-9099	309-0912	393-0112	
70796	TriSeal		392-9094	309-0903	393-0103	
70797	TriSeal		392-9096			
70798	TriSeal		392-9132			
70799	TriSeal		392-9131	309-0973	393-0173	393-0473
712834	GMC/Volvo		392-9099	309-0912	393-0112	
719021	C/R	330-3077				
720659	GMC/Volvo		372-7097	307-0743	373-0143	373-0443
730003	National	330-3025				
730003	National	330-3035				
730004	National	330-3024				
730006	National	330-3046				
730008	National	330-3040				
730009	National	330-3019				
730016	National	330-3041				
730017	National	330-3044				
730018	National	330-3006				
730019	National	330-3031				
730022	National	330-3011				
730024	National	330-3060				
730026	National	330-3012				
730027	National	330-3034				
730030	National	330-3056				
730031	National	330-3037				
730149	National	330-3097				
733067	National	330-3009/3067				
733105	National	330-3105				
733106	National	330-3106				
733107	National	330-3107				
733108	National	330-3108				

(Continued Next Page)

CROSS REFERENCE

Information contained in this section is furnished as a guide. Verify specific application elsewhere in this catalog when possible.

COMPETITIVE PART NO.	COMPETITOR'S NAME	STEMCO MISC PRODUCTS	STEMCO STD/GRIT GUARD®	STEMCO GUARDIAN®	STEMCO VOYAGER®	DISCOVER® XR
733109	National	330-3109				
733110	National	330-3110				
733111	National	330-3111				
733112	National	330-3112				
733113	National	330-3113				
733114	National	330-3114				
733115	National	330-3115				
7378	National		392-9087			
745400P	Mechanex/Barrier		372-7099	307-0723	373-0123	373-0423
747400P	Mechanex/Barrier		372-7098	307-0713	373-0113	
749400P	Mechanex/Barrier		372-7095	307-0744	373-0144	
755400P	Mechanex/Barrier		372-7097	307-0743	373-0143	373-0443
761400P	Mechanex/Barrier		392-9131	309-0973	393-0173	393-0473
770400P	Mechanex/Barrier		392-9099	309-0912	393-0112	
775698C91	Navistar		392-9131	309-0973	393-0173	393-0473
780316C91	Navistar			308-0853		
781265C91	Navistar	343-4249				
785400P	Mechanex/Barrier		392-9094	309-0903	393-0103	
794408C91	Navistar		382-8064	308-0864	383-0164	383-0464
79470	Eaton	460-6002				
7EQH1175	Ford		392-9099	309-0912	393-0112	
8061231	GMC/Volvo	330-3009				
8069924	GMC/Volvo	343-4024				
806994	GMC/Volvo	343-4024				
810196	Eaton	320-2137				
812928	Eaton	343-4095				
815214	Eaton	343-4195				
815215	Eaton		372-7099	307-0723	373-0123	373-0423
815312	Eaton	330-3106				
815996	Eaton	343-4264				
820394	Eaton	447-4743				
820395	Eaton	447-4743				
821187	Eaton	340-5098				
821338	Eaton	343-4009				
821601	Eaton		372-7097	307-0743	373-0143	373-0443
821604	Eaton	315-1504				
821610	Eaton	320-2110				
821615	Eaton	340-4119				
821907	Eaton	343-4009				
847	NOK		382-8036	308-0836	383-0136	383-0436
848	NOK		392-9099			
849	NOK		392-9099	309-0912	393-0112	
850	NOK		372-7098	307-0713	373-0113	
851	NOK		372-7099	307-0723	373-0123	373-0423
852	NOK		392-9112	309-0904	393-0104	
853	NOK		372-7095	307-0744	373-0144	
854	NOK		392-9092			

CROSS REFERENCE

Information contained in this section is furnished as a guide. Verify specific application elsewhere in this catalog when possible.

COMPETITIVE PART NO.	COMPETITOR'S NAME	STEMCO MISC PRODUCTS	STEMCO STD/GRIT GUARD®	STEMCO GUARDIAN®	STEMCO VOYAGER®	DISCOVER® XR
855	NOK			308-0853		
856	NOK		392-9094	309-0903	393-0103	
857	NOK				383-0156	
858381	GMC/Volvo	343-4024				
858381	Western Star	343-4024				
859	NOK		372-7097	307-0743	373-0143	373-0443
860	NOK		392-9132			
861	NOK		392-9131	309-0973	393-0173	393-0473
86109	Trailmobile	347-4009				
862500	GMC/Volvo	343-4009				
862500	Western Star	343-4009				
862501	Western Star	330-3009/3067				
862739C91	Navistar		392-9036			
862935C1	Navistar	310-1063				
863	NOK		382-8064	308-0864	383-0164	383-0464
864643C91	Navistar		392-9099	309-0912/0915		
864643C92	Navistar		392-9099	309-0912/0915		
864784C91	Navistar		392-9099	309-0912/0915		
8668	Trailmobile	340/343-4009				
868861R1	Navistar	330-3024				
870889C91	Navistar		382-8064	308-0864	383-0164	383-0464
870890C91	Navistar		382-8064	308-0864	383-0164	383-0464
8720	Trailmobile	330-3009				
875188R2	Navistar		392-9099	309-0912/0915		
88319	NOK			309-0973	393-0173	393-0473
88327	Eaton					
8872	National		382-8064	308-0864	383-0164	383-0464
8873095	GMC/Volvo	460-6006				
88AX177	Mack		392-9094	309-0903	393-0103	
88AX372	Mack		392-9098	309-0948	393-0148	
88AX375	Mack		392-9089	309-0948	393-0148	
88AX376	Mack		392-9089	309-0948	393-0148	
88AX382	Mack		392-9089	309-0948	393-0148	
88AX402	Mack		392-9089	309-0948	393-0148	
88AX403	Mack		392-9089	309-0948	393-0148	
88AX404	Mack		392-9089	309-0948	393-0148	
88AX405	Mack		392-9112	309-0904	393-0104	
88AX407	Mack		392-9094	309-0903	393-0103	
88AX418	Mack		392-9112	309-0904	393-0104	
88AX420	Mack		392-9131	309-0973	393-0173	393-0473
88AX421	Mack		392-9094	309-0903	393-0103	
88AX424	Mack		392-9089	309-0948	393-0148	
88AX427	Mack		392-9096			
88AX432	Mack	320-2009				
88AX448	Mack		392-9112	309-0904	393-0104	
88AX450	Mack		392-9132			
88AX461	Mack		392-9131	309-0973	393-0173	393-0473

(Continued Next Page)

CROSS REFERENCE

Information contained in this section is furnished as a guide. Verify specific application elsewhere in this catalog when possible.

COMPETITIVE PART NO.	COMPETITOR'S NAME	STEMCO MISC PRODUCTS	STEMCO STD/GRIT GUARD®	STEMCO GUARDIAN®	STEMCO VOYAGER®	DISCOVER® XR
88AX466	Mack		392-9112	309-0904	393-0104	
88AX467	Mack		392-9094	309-0903	393-0103	
88AX469	Mack		382-8064	308-0864	383-0164	383-0464
891016	Western Star	320-2001				
896941R91	Navistar		382-8064	308-0864	383-0164	383-0464
898235R92	Navistar	320-2114				
898235R93	Navistar		392-9096			
900868	Trailmobile	343-4075				
90155	National		392-9131	309-0973	393-0173	393-0473
9022299832	Heil	343-4075				
9022299868	Heil		372-7099	307-0723	373-0123	373-0423
90501017	Trailmobile		372-7097	307-0743	373-0143	373-0443
90501018	Trailmobile	320-2023				
9156004	GMC/Volvo	310-1010				
921010001	Western Star	330-3097				
921010002	GMC/Volvo	343-4024				
921010003	GMC/Volvo	343-4046				
921010009	GMC/Volvo	340/343-4009				
921010024	GMC/Volvo	340-4119				
921010034	GMC/Volvo	343-4095				
921010043	GMC/Volvo	343-4281				
921015015	GMC/Volvo	343-4009				
921020001	GMC/Volvo	330-3097				
921030002	GMC/Volvo	359-5990				
93395	National		382-8036	308-0836	383-0136	383-0436
940010001	GMC/Volvo		382-8064	308-0864	383-0164	383-0464
940010002	GMC/Volvo	320-2099				
940010002	Western Star	320-2099				
940010005	GMC/Volvo	320-2137				
940010005	Western Star	320-2137				
940010006	GMC/Volvo		372-7097	307-0743	373-0143	373-0443
940010007	GMC/Volvo		392-9053			
940010010	GMC/Volvo		382-8036	308-0836	383-0136	383-0436
940010011	GMC/Volvo		392-9087			
940010013	GMC/Volvo		392-9087			
940010013	Western Star	320-2162				
940010014	GMC/Volvo		382-8036	308-0836	383-0136	383-0436
940010015	GMC/Volvo		392-9087			
940010017	GMC/Volvo		392-9099	309-0912		
940010019	GMC/Volvo		392-9131	309-0973	393-0173	393-0473
940010021	GMC/Volvo		382-8036	308-0836	383-0136	383-0436
940010022	GMC/Volvo		392-9131	309-0973	393-0173	393-0473
940010022	Western Star		392-9131	309-0973	393-0173	393-0473
940010028	GMC/Volvo		392-9131	309-0973	393-0173	393-0473
940010029	GMC/Volvo		382-8036	308-0836	383-0136	383-0436
940010030	GMC/Volvo		392-9131	309-0973	393-0173	393-0473
940010034	GMC/Volvo		392-9131	309-0973	393-0173	393-0473

CROSS REFERENCE

Information contained in this section is furnished as a guide. Verify specific application elsewhere in this catalog when possible.

COMPETITIVE PART NO.	COMPETITOR'S NAME	STEMCO MISC PRODUCTS	STEMCO STD/GRIT GUARD®	STEMCO GUARDIAN®	STEMCO VOYAGER®	DISCOVER® XR
940010038	GMC/Volvo		382-8064	308-0864	383-0164	383-0464
940010039	GMC/Volvo		382-8036	308-0836	383-0136	383-0436
940010040	GMC/Volvo		392-9131	309-0973	393-0173	393-0473
940013406	GMC/Volvo	320-2110				
940013406	Western Star	320-2110				
940013409	GMC/Volvo		372-7097	307-0743	373-0143	373-0443
940013410	GMC/Volvo		372-7097	307-0743	373-0143	373-0443
940013412	Western Star		372-7097	307-0743	373-0143	373-0443
940013604	GMC/Volvo		382-8036	308-0836	383-0136	383-0436
940013802	GMC/Volvo	320-2109				
940013804	GMC/Volvo	320-2110				
940013902	Western Star		382-8064	308-0864	383-0164	383-0464
940015001	Western Star		382-8036	308-0836	383-0136	383-0436
940040001	GMC/Volvo	310-1089				
940040001	Western Star	310-1089				
940043802	GMC/Volvo	315-1504				
94RU150	Mack	359-5990				
94RU19309	Mack	330-3024				
94RU262	Mack	330-3025				
94RU263	Mack	330-3009/3067				
94RU263P2	Mack	330-3097				
94RU263P3	Mack	330-3122				
94RU264	Mack	330-3046				
94RU265	Mack	330-3008				
94RU266	Mack	330-3031				
94RU267	Mack	330-3046				
94RU278	Mack	330-3012				
95357	Eaton		392-9099	309-0912/0915		
9584	National			309-0935		
966446R91	Navistar	460-6001				
972401R91	Navistar		392-9099	309-0912/0915		
972424R91	Navistar	460-6012				
974526R91	Navistar		392-9131	309-0973	393-0173	393-0473
982259R91	Navistar		392-9001			
983570R1	Navistar		392-9131	309-0973	393-0173	393-0473
992481C91	Navistar		382-8066	308-0866	383-0166	
992484C91	Navistar				383-0156	
992485C91	Navistar				383-0156	
A1205B1250	Meritor	320-2110				
A1205B2264	Meritor		382-8036	308-0836	383-0136	383-0436
A1205C1381	Meritor	320-2105				
A1205C1719	Meritor		382-8071			
A1205C1875	Meritor		372-7098	307-0713	373-0113	
A1205C1875	Meritor					
A1205C2343	Meritor		372-7097	307-0743	373-0143	373-0443
A1205D1070	Meritor	320-2137				
A1205D2526	Meritor		392-9099	309-0912	393-0112	

(Continued Next Page)

CROSS REFERENCE

Information contained in this section is furnished as a guide. Verify specific application elsewhere in this catalog when possible.

COMPETITIVE PART NO.	COMPETITOR'S NAME	STEMCO MISC PRODUCTS	STEMCO STD/GRIT GUARD®	STEMCO GUARDIAN®	STEMCO VOYAGER®	DISCOVER® XR
A1205D2578	Meritor		382-8064	308-0864	383-0164	383-0464
A1205E1799	Meritor		372-7098	307-0713	373-0113	
A1205E2475	Meritor		382-8036	308-0836	383-0136	383-0436
A1205F136	Meritor				383-0101	
A1205F2554	Meritor		382-8066	308-0866	383-0166	
A1205G1515	Meritor			308-0863		
A1205G2191	Meritor		372-7097	307-0743	373-0143	373-0443
A1205G2503	Meritor		392-9099	309-0912	393-0112	
A1205G631	Meritor		382-8036	308-0836	383-0136	383-0436
A1205H1100	Meritor	320-2061				
A1205J2194	Meritor		392-9131	309-0973	393-0173	393-0473
A1205J2350	Meritor		392-9132			
A1205K1285	Meritor	320-2106				
A1205K2351	Meritor		372-7099	307-0723	373-0123	373-0423
A1205K999	Meritor		372-7097	307-0743	373-0143	373-0443
A1205L1338	Meritor		382-8036	308-0836	383-0136	383-0436
A1205L1546	Meritor				393-0134	
A1205L1598	Meritor		372-7097	307-0743	373-0143	373-0443
A1205L2352	Meritor		392-9131	309-0973	393-0173	393-0473
A1205M1339	Meritor		382-8064	308-0864		
A1205M897	Meritor		372-7098	307-0713	373-0113	
A1205N1912	Meritor		382-8036	308-0836	383-0136	383-0436
A1205N898	Meritor		372-7095	307-0744	373-0144	
A1205P1108	Meritor		382-8064	308-0864	383-0164	383-0464
A1205P1212	Meritor		372-7097	307-0743	373-0143	373-0443
A1205P1888	Meritor		372-7099	307-0723	373-0123	373-0423
A1205Q1889	Meritor		372-7099	307-0713	373-0123	373-0423
A1205Q1915	Meritor	460-6012				
A1205Q2487	Meritor		392-9131	309-0973	393-0173	393-0473
A1205R1630	Meritor		392-9087			
A1205R2410	Meritor		392-9131	309-0973	393-0173	393-0473
A1205R2566	Meritor		372-7097	307-0743	373-0143	373-0443
A1205S2307	Meritor		382-8064	308-0864	383-0164	383-0464
A1205T696	Meritor		392-9131	309-0973	393-0173	393-0473
A1205T774	Meritor		392-9053			
A1205U1061	Meritor		392-9131	309-0973	393-0173	393-0473
A1205U1659	Meritor	320-2099				
A1205U1711	Meritor	320-2133				
A1205U2101	Meritor		392-9131	309-0973	393-0173	393-0473
A1205U2205	Meritor		372-7062			
A1205U2491	Meritor		382-8036	308-0836	383-0136	383-0436
A1205U697	Meritor		392-9087			
A1205V1192	Meritor	320-2086				
A1205V2180	Meritor		392-9131	309-0973	393-0173	393-0473
A1205V2492	Meritor		392-9131	309-0973	393-0173	393-0473
A1205W1349	Meritor		392-9099	309-0912/0915		
A1205W1375	Meritor		382-8036	308-0836	383-0136	383-0436

CROSS REFERENCE

Information contained in this section is furnished as a guide. Verify specific application elsewhere in this catalog when possible.

COMPETITIVE PART NO.	COMPETITOR'S NAME	STEMCO MISC PRODUCTS	STEMCO STD/GRIT GUARD®	STEMCO GUARDIAN®	STEMCO VOYAGER®	DISCOVER® XR
A1205W1557	Meritor			309-0935		
A1205W1557	Meritor		392-9036			
A1205X1662	Meritor		372-7097	307-0743	373-0143	373-0443
A1205X2702	Meritor		372-7097	307-0743	373-0143	373-0443
A1205X700	Meritor		392-9001			
A1205Y1975	Meritor		372-7099	307-0723	373-0123	373-0423
A1205Z1742	Meritor	320-2104				
A1205Z1820	Meritor		392-9053			
A1205Z2470	Meritor		392-9099	309-0912/0915		
A1205Z780	Meritor	382-8064	308-0864			
A-1227-A-105	Meritor	448-4836				
A-1227-S-331	Meritor	449-4973				
A1805S615	Meritor		392-9094	309-0903	393-0103	
A1805V542	Meritor		392-9131	309-0973	393-0173	393-0473
A2208N820	Meritor	330-3097				
A3262A1353	Meritor	343-4176				
A3262C133	Meritor	343-4009				
A3262D264	Meritor	343-4249				
A3262G1177	Meritor	343-4095				
A3262G215	Meritor	343-4024				
A3262H1048	Meritor	347-4009				
A3262H398	Meritor	343-4009				
A3262J1180	Meritor	343-4195				
A3262M1183	Meritor	341-4009				
A3262Q277	Meritor	343-4065				
A3262Q407	Meritor	343-4075				
A3262T1216	Meritor	343-4024				
ACA5207	Fruehauf		372-7099	307-0723	373-0123	373-0423
ACA52071	Fruehauf		372-7099	307-0723	373-0123	373-0423
ACE55171	Fruehauf		372-7099	307-0723	373-0123	373-0423
ACE-8510-001	Fruehauf	447-4723				
ACF006562	Fruehauf		372-7099	307-0723	373-0123	373-0423
ACF6562	Fruehauf		372-7099	307-0723	373-0123	373-0423
AR10	National	310-1041				
AR4	National	310-1051				
AR5	National	310-1050				
AX12-1500	Axilok	448-4836				
AX12-3250	Axilok	449-4973				
AX12-3480	Axilok	447-4723				
AX12-3500	Axilok	447-4724				
AX16-2625	Axilok	447-4743				
AX18-1500	Axilok	448-4837				
AXA0043	Fruehauf		372-7099	307-0723	373-0123	373-0423
B370131BGO	National				383-0156	
B6Q1175A	Ford			309-0935		
C5TA1190B	Ford		382-8064	308-0864	383-0164	383-0464
C5TZ1190B	Ford		382-8064	308-0864	383-0164	383-0464

(Continued Next Page)

CROSS REFERENCE

Information contained in this section is furnished as a guide. Verify specific application elsewhere in this catalog when possible.

COMPETITIVE PART NO.	COMPETITOR'S NAME	STEMCO MISC PRODUCTS	STEMCO STD/ GRIT GUARD®	STEMCO GUARDIAN®	STEMCO VOYAGER®	DISCOVER® XR
C9HZ1175A	Ford		392-9096			
D0HA1131U	Ford	343-4024				
D0HA1153M	Ford	330-3012				
D0HA1153R	Ford	330-3024				
D0HA1153S	Ford	330-3040				
D0HA1190S	Ford	320-2105				
D0HZ1131A	Ford	343-4065				
D0HZ1131C	Ford	343-4024				
D0HZ1153A	Ford	330-3040				
D0HZ1153C	Ford	330-3024				
D0HZ1153D	Ford	330-3009				
D0HZ1153G	Ford	330-3012				
D0HZ1153J	Ford	330-3040				
D0HZ1173A	Ford	310-1064				
D0HZ1175B	Ford			309-0935		
D0HZ1175D	Ford		392-9099	309-0912, 0915		
D0HZ1175E	Ford		392-9096			
D0HZ1190B	Ford		382-8036	308-0836	383-0136	383-0436
D0HZ1A131A	Ford	359-5990				
D0TZ1175B	Ford			309-0935		
D0TZ1175D	Ford		392-9099	309-0912, 0915		
D1HA1131EA	Ford	343-4124				
D1HA1131KA	Ford	343-4249				
D1HA1190AA	Ford		382-8036	308-0836	383-0136	383-0436
D1HS1175BA	Ford		392-9096			
D1HS1190AA	Ford			308-0863		
D1HZ1190A	Ford		382-8036	308-0836	383-0136	383-0436
D2HA4813AA	Ford	460-6007				
D3HS1175BA	Ford	320-2102				
D3TA1190B1A	Ford			308-0863		
D5H-3104A	Ford	448-4837				
D5HA1175AA	Ford	320-2106				
D5HZ1175A	Ford		392-9131	309-0973	393-0173	393-0473
D5HZ1190A	Ford			308-0863		
D5HZ1190B	Ford		382-8036	308-0836	383-0136	383-0436
D5HZ1190C	Ford		382-8064	308-0864	383-0164	383-0464
D5HZ1190D	Ford		382-8064	308-0864	383-0164	383-0464
D5HZ1190E	Ford			308-0863		
D7HD1173AA	Ford	310-1089				
D7HD1175AA	Ford	320-2099				
D7HT1175BA	Ford	320-2001				
D7HZ1175D	Ford		392-9131	309-0973	393-0173	393-0473
D7HZ1175E	Ford		392-9001			
D7HZ4255A	Ford	449-4974				
D7HZ4245A	Ford	449-4974				
DG516P	Dual Dynamics	340-4013				
DG516PS	Dual Dynamics	343-4013				

CROSS REFERENCE

Information contained in this section is furnished as a guide. Verify specific application elsewhere in this catalog when possible.

COMPETITIVE PART NO.	COMPETITOR'S NAME	STEMCO MISC PRODUCTS	STEMCO STD/ GRIT GUARD®	STEMCO GUARDIAN®	STEMCO VOYAGER®	DISCOVER® XR
DG6F	Dual Dynamics	340-4046				
DG6F4.5	Dual Dynamics	340-4024				
DG6FL	Dual Dynamics	340-4249				
DG6P	Dual Dynamics	340-4009				
DG6PS	Dual Dynamics	343-4009				
DGP	Dual Dynamics	340-4075				
DGPS	Dual Dynamics	343-4075				
E-540	Euclid	447-4743				
E-572	Euclid	447-4743				
E-576	Euclid	448-4836				
E-1087	Euclid	448-4836				
E-2296	Euclid	448-4836				
E-2299	Euclid	448-4836				
E-2303	Euclid	449-4973				
E-2305	Euclid	449-4973				
E-2420	Euclid	447-4743				
E-2422	Euclid	447-4743				
E-2460	Euclid	447-4743				
E-2466	Euclid	449-4973				
E-2468	Euclid	449-4973				
E-2550	Euclid	447-4723				
E-4861	Euclid	448-4837				
E-6140	Euclid	449-4973				
E0HZ1A131B	Ford	359-5915				
E1HT1175BA	Ford		392-9131	309-0973	393-0173	393-0473
E1HZ1175A	Ford		392-9131	309-0973	393-0173	393-0473
E1HZ1175B	Ford		392-9131	309-0973	393-0173	393-0473
E2HT1190AA	Ford		382-8036	308-0836	383-0136	383-0436
E2HT1190BA	Ford		382-8064	308-0864	383-0164	383-0464
E2HZ1175A	Ford		392-9131	309-0973	393-0173	393-0473
E2HZ1177A	Ford		392-9131	309-0973	393-0173	393-0473
E3HS1131AA	Ford	343-4009				
E3HZ1190B	Ford		382-8036	308-0836	383-0136	383-0436
E3HZ1190C	Ford		382-8064	308-0864	383-0164	383-0464
E4HS-4255-AA	Ford	449-4973				
E4HT1175AA	Ford		392-9131	309-0973	393-0173	393-0473
E4HZ1175B	Ford		392-9131	309-0973	393-0173	393-0473
E5HT1175CA	Ford		392-9099	309-0912, 0915		
E5HT1175GA	Ford		392-9131	309-0973	393-0173	393-0473
E5HT1190AA	Ford			308-0863		
E5HZ1131A	Ford	343-4046				
E5HZ1131B	Ford	343-4095				
E5HZ1190A	Ford			308-0863		
E5TZ1177B	Ford			309-0935		
E6HT1175AA	Ford		392-9099	309-0912, 0915		
E6HZ1175C	Ford		392-9099	309-0912, 0915		
E6HZ1175E	Ford		392-9099	309-0912, 0915		

(Continued Next Page)

CROSS REFERENCE

Information contained in this section is furnished as a guide. Verify specific application elsewhere in this catalog when possible.

COMPETITIVE PART NO.	COMPETITOR'S NAME	STEMCO MISC PRODUCTS	STEMCO STD/GRIT GUARD®	STEMCO GUARDIAN®	STEMCO VOYAGER®	DISCOVER® XR
E6HZ1190A	Ford			308-0863		
E6HZ1190D	Ford		382-8036	308-0836	383-0136	
E7HT1175AA	Ford			309-0935		
E7HT1190AA	Ford		382-8036	308-0836	383-0136	383-0436
E7HZ1175A	Ford		392-9035	309-0935		
E7HZ1190A	Ford		382-8036	308-0836	383-0136	383-0436
E8HS1175BA	Ford		392-9131	309-0973	393-0173	393-0473
E8HS1175CA	Ford		392-9131	309-0973	393-0173	393-0473
E8HS1190CA	Ford		382-8036	308-0836	383-0136	383-0436
E8TW1177BA	Ford			309-0935		
E8TZ1177B	Ford			309-0935		
FOHT1190AA	Ford		382-8036	308-0836	383-0136	383-0436
FOTZ1177A	Ford			309-0935		
FOTZ1177AA	Ford			309-0935		
F-940	Eaton	447-4743				
F-941	Eaton	447-4743				
F-1529	Eaton	447-4743				
F-1530	Eaton	447-4743				
F18571	Eaton		382-8064	308-0864	383-0164	383-0464
F18572	Eaton		382-8064	308-0864	383-0164	383-0464
F1HS1175AA	Ford		392-9099	309-0912, 0915		
F1HT1131AA	Ford	343-4065				
F1HZ1175A	Ford		392-9099	309-0912, 0915		
F1HZ1175C	Ford		392-9096			
F2HS1131AA	Ford	343-4281				
F2HS1190AA	Ford		382-8064	308-0864	383-0164	383-0464
F2HS3276AA	Ford	448-4837				
F2HT1175AA	Ford		392-9099	309-0912, 0915		
F2HZ1175A	Ford			309-0935		
F2HZ1175B	Ford		392-9099	309-0912, 0915		
F2HZ1175C	Ford		392-9131	309-0973	393-0173	393-0473
F3HS1175AA	Ford		392-9099	309-0912, 0915		
F3HT1131BA	Ford	343-4124				
F3HT1153AA	Ford	330-3024				
F3HT1175AA	Ford			309-0935		
F3HZ1131C	Ford	343-4024				
F3TW1177CA	Ford			309-0935		
F4HS1175BA	Ford		392-9131	309-0973	393-0173	393-0473
F4TZ1177B	Ford			309-0935		
F4TZ1177C	Ford			309-0935		
H075	National	343-4075				
HI004320	Monon	347-4009				
HI004323	Monon	320-2110				
HI004324	Monon	315-1504				
H1004325	Monon	343-4009				
H1004326	Monon	330-3009				
HI036513	Monon				373-0113	

CROSS REFERENCE

Information contained in this section is furnished as a guide. Verify specific application elsewhere in this catalog when possible.

COMPETITIVE PART NO.	COMPETITOR'S NAME	STEMCO MISC PRODUCTS	STEMCO STD/GRIT GUARD®	STEMCO GUARDIAN®	STEMCO VOYAGER®	DISCOVER® XR
HS1643	Mechanex/Barrier	343-4249				
HS34386	Mechanex/Barrier			309-0935		
HS34972	Mechanex/Barrier			308-0863		
HS34999	Mechanex/Barrier		392-9036			
HS35059	Mechanex/Barrier		382-8036	308-0836	383-0136	383-0436
HS36357	Mechanex/Barrier		382-8071			
HS38748	Mechanex/Barrier		392-9099	309-0912/0915		
HS38779	Mechanex/Barrier		392-9099	309-0912/0915		
HS40133	Mechanex/Barrier		372-7098	307-0713	373-0113	
HS42622	Mechanex/Barrier		372-7099	307-0723	373-0123	373-0423
HS42671	Mechanex/Barrier		392-9112	309-0904	393-0104	
HS43753	Mechanex/Barrier		372-7095	307-0744	373-0144	
HS43763	Mechanex/Barrier		382-8064	308-0864	383-0164	383-0464
HS43861	Mechanex/Barrier		392-9096			
HS44919	Mechanex/Barrier			308-0853		
HS45097	Mechanex/Barrier		392-9094	309-0903	393-0103	
HS45102	Mechanex/Barrier				383-0156	
HS453795	Mechanex/Barrier	330-3009				
HS455037	Mechanex/Barrier	310-1051				
HS46304	Mechanex/Barrier		372-7097	307-0743	373-0143	373-0443
HS47245	Mechanex/Barrier					
HS47694	Mechanex/Barrier		392-9131	309-0973	393-0173	393-0173
HD47695	Mechanex/Barrier		392-9131	309-0973	393-0173	393-0173
HS48001	Mechanex/Barrier		392-9132			
HU007A	National	340-4370				
HU008A	National	343-4006				
HU008A	National	343-4008				
HU009A	National	343-4009				
HU009A	National	343-4046				
HU009A	National	343-4098				
HU013A	National	343-4013				
HU024A	National	343-4024				
HU036A	National	343-4025				
HU037A	National	343-4037				
HU057A	National	343-4057				
HU065A	National	343-4065				
HU110A	National	343-4095				
HU110A	National	343-4249				
K1501	Ceromet	450-4836				
K1502	Ceromet	450-4837				
K2625	Ceromet	450-4743				
K3250	Ceromet	450-4973				
K3480	Ceromet	450-4723				
KBE-10227	Fruehauf	448-4836				
L-176	Leland	447-4743				
L-178	Leland	447-4743				
L-195	Leland	448-4836				

(Continued Next Page)

CROSS REFERENCE

Information contained in this section is furnished as a guide. Verify specific application elsewhere in this catalog when possible.

COMPETITIVE PART NO.	COMPETITOR'S NAME	STEMCO MISC PRODUCTS	STEMCO STD/ GRIT GUARD®	STEMCO GUARDIAN®	STEMCO VOYAGER®	DISCOVER® XR
L-1331	Leland	448-4836				
L-1334	Leland	448-4836				
L-1347	Leland	447-4743				
L-1349	Leland	447-4743				
L-1353	Leland	449-4973				
L-1355	Leland	449-4973				
L-1359	Leland	447-4743				
L-1361	Leland	447-4743				
L-1365	Leland	449-4973				
L-1367	Leland	449-4973				
L-1395	Leland	447-4723				
M10312-001	Spicer-Dana	447-4743				
M10HG108	Spicer-Dana	330-3009				
M10HG109	Spicer-Dana	330-3084				
M10HG111	Spicer-Dana	330-3062				
M10HG113	Spicer-Dana	330-3017				
M10HG115	Spicer-Dana	330-3056				
M10HG119	Spicer-Dana	330-3102				
M10GH124	Spicer-Dana	330-3024				
M10HG127	Spicer-Dana	330-3079				
M10HH101	Spicer-Dana	320-2109				
M10HH102	Spicer-Dana	320-2110				
M10HH107	Spicer-Dana		372-7097	307-0743	373-0143	373-0443
M10HH111	Spicer-Dana	320-2111				
M10HH119	Spicer-Dana	320-2041				
M10HH125	Spicer-Dana	320-2173				
M10HH128	Spicer-Dana	320-2018				
M10HH138	Spicer-Dana	320-2023				
M10HH153	Spicer-Dana		372-7097	307-0743	373-0143	373-0443
M10HH154	Spicer-Dana		382-8036	308-0836	383-0136	383-0436
M10HH157	Spicer-Dana		372-7099	307-0723	373-0123	373-0423
M10HK124	Spicer-Dana	340/343-4009				
M10HK143	Spicer-Dana	340-4157				
M10HK162	Spicer-Dana	343-4075				
M10HK170	Spicer-Dana	343-4024				
M10HK182	Spicer-Dana	340/343-4009				
M10HK184	Spicer-Dana	343-4009				
M10HK185	Spicer-Dana	343-4249				
M10HN101	Spicer-Dana	447-4743				
M10HS104	Spicer-Dana	310-1013				
M-682	BWP	447-4743				
M-684	BWP	447-4743				
M-685	BWP	448-4836				
M-1524	BWP	448-4836				
M-1956	BWP	448-4836				
M-1959	BWP	448-4836				
M-1972	BWP	447-4743				

CROSS REFERENCE

Information contained in this section is furnished as a guide. Verify specific application elsewhere in this catalog when possible.

COMPETITIVE PART NO.	COMPETITOR'S NAME	STEMCO MISC PRODUCTS	STEMCO STD/ GRIT GUARD®	STEMCO GUARDIAN®	STEMCO VOYAGER®	DISCOVER® XR
M-1974	BWP	447-4743				
M-1978	BWP	449-4973				
M-1980	BWP	449-4973				
M-1984	BWP	447-4743				
M-1986	BWP	447-4743				
M-1990	BWP	449-4973				
M-1992	BWP	449-4973				
M-1996	BWP	447-4723				
NP026773	TIMKEN	HM212011				
NP034946	TIMKEN	594A				
NP053874	TIMKEN	572				
NP174964	TIMKEN	HM518445				
NP363298	TIMKEN	592A				
NP435398	TIMKEN	3720				
NP503727	TIMKEN	HM218210				
NP593561	TIMKEN	HM518410				
NP840302	TIMKEN	580				
NP874005	TIMKEN	3782				
NP899357	TIMKEN	HM212049				
NP965350	TIMKEN	HM218248				
R20148201	Strick	340/343-4009				
R20148202	Strick	330-3009				
R20148216	Strick	320-2110				
R20148217	Strick	315-1504				
R20148218	Strick	343-4195				
R20148219	Strick	330-3118				
R20148220	Strick	347-4009				
R20148222	Strick		372-7097	307-0743	373-0143	373-0443
R20148223-4	Strick		372-7099	307-0723	373-0123	373-0423
R20148225	Strick	343-4075				
R20148227	Strick	340/343-4009				
R20148501	Strick	640-0001				
SS46842	Victor		372-7098	307-0713	373-0113	
SS46842-1	Victor		372-7098	307-0713	373-0113	
SS46847	Victor		372-7095	307-0744	373-0144	
SS47889	Victor		392-9096			
SS48087	Victor		372-7099	307-0723	373-0123	373-0423
SS64234-1	Victor		382-8001			
SS64236	Victor		372-7097	307-0743	373-0143	373-0443
SS64240-1	Victor		372-7015			
SS64414	Victor		382-8036	308-0836	383-0136	383-0436
SS64415	Victor			308-0853		
SS64452	Victor		392-9094	309-0903	393-0103	
SS64471	Victor		372-7049			
SS64487	Victor		382-8019			
SS64517	Victor		382-8064	308-0864	383-0164	383-0464
SS64530	Victor		382-8036	308-0836	383-0136	383-0436

(Continued Next Page)

CROSS REFERENCE

Information contained in this section is furnished as a guide. Verify specific application elsewhere in this catalog when possible.

COMPETITIVE PART NO.	COMPETITOR'S NAME	STEMCO MISC PRODUCTS	STEMCO STD/ GRIT GUARD®	STEMCO GUARDIAN®	STEMCO VOYAGER®	DISCOVER® XR
SS64538	Victor			308-0863		
SS64539	Victor				383-0156	
SS64542	Victor		392-9094	309-0903	393-0103	
SS64546	Victor		392-9087			
SS64553	Victor		392-9096			
SS64558	Victor			309-0935		
SS64558-1	Victor		392-9036			
SS64567	Victor		392-9112	309-0904	393-0104	
SS64569	Victor		392-9089	309-0948	393-0148	
SS64584	Victor		392-9099			
SS64603	Victor		392-9131	309-0973	393-0173	393-0473
SS68001	Victor		372-7098	307-0713	373-0113	
SS68002	Victor		372-7099	307-0723	373-0123	373-0423
SS68003	Victor		372-7097	307-0743	373-0143	373-0443
SS68004	Victor		392-9132			
SS68005	Victor			372-7091		
SS68006	Victor		392-9131	309-0973	393-0173	393-0473
SS68008	Victor		372-7097	307-0743	373-0143	373-0443
T13501317	Dodge		392-9099	309-0912/0915		
TP-157	Transit	448-4836				
TP-431	Transit	448-4836				
TP-489	Transit	447-4743				
TP-490	Transit	447-4743				
TP-1572	Transit	449-4973				
TP-1943	Transit	449-4973				
TP-1970	Transit	448-4836				

CROSS REFERENCE

Information contained in this section is furnished as a guide. Verify specific application elsewhere in this catalog when possible.

COMPETITIVE PART NO.	COMPETITOR'S NAME	STEMCO MISC PRODUCTS	STEMCO STD/ GRIT GUARD®	STEMCO GUARDIAN®	STEMCO VOYAGER®	DISCOVER® XR
TP-1973	Transit	448-4836				
TP-1977	Transit	449-4973				
TP-1978	Transit	449-4973				
TP-1988	Transit	447-4743				
TP-1989	Transit	447-4743				
TP-1997	Transit	447-4743				
TP-1999	Transit	447-4743				
UH0389EO UZ208EO	NOK	429-0005				
UZ0255E0	NOK	460-6012				
UZ0301E0	NOK		372-7098	307-0713	373-0113	
UZ0302E0	NOK		372-7099	307-0723	373-0123	373-0423
UZ0303E0	NOK		372-7097	307-0743	373-0143	373-0443
UZ0304E0	NOK		392-9131	309-0973	393-0173	393-0473
UZ0305E0	NOK		382-8036	308-0836	383-0136	383-0436
UZ0306E0	NOK		392-9099	309-0912	393-0112	
V10895522	GMC/Volvo			308-0870		
V8027329	GMC/Volvo	343-4095				
V8027330	GMC/Volvo		382-8064	308-0864	383-0164	383-0464
W03HH101	Dana		382-8064	308-0864	383-0164	383-0464
W03HH102	Dana		382-8036	308-0836	383-0136	383-0436
W03HK100	Dana	343-4249				
X-115	Eaton	448-4836				
Z1026AD	Eaton	310-1041				
Z1026L	Eaton	310-1050				
Z1026T	Eaton		392-9112	309-0604	393-0104	

(Continued Next Page)

HELP KEEP THE ROADWAYS SAFE WITH PROPER INSTALLATION



Proper installation of all components is important to ensure that your teams are Making the Roadways Safer®. When teams follow the proper installation steps (as laid out in the following section), you can also be sure your STEMCO parts will do what they're designed to do — which is to last longer, perform exceptionally and save you money.

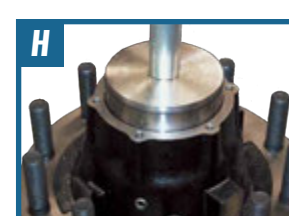

BEARING REMOVAL AND INSTALLATION

REMOVAL STEP 1

Remove hub/wheel assembly from vehicle in accordance with recommended practices. (See **FIGURE A**)

STEP 2

Remove inboard and outboard bearing cones and set aside for inspection.

STEP 3

Using a mild steel drift or cup driver, carefully drive out the bearing cups. (See **FIGURE B**)

NOTE: Caution should be used when driving bearing cups, as drifts and other tools can damage bearings.

NOTE: Drifts can damage hub bearing bores. Be careful not to score bores while removing cups, especially when using aluminum hubs.

INSPECTION

STEP 1

Inspect the hub bearing bores and shoulders for damage. The bores should be smooth and free from scoring, burrs, indications of cup spinning, or other forms of damage. Remove any burrs or raised areas using emery cloth, a file, or other appropriate tool. (See **FIGURE C**)

STEP 2

Measure the bearing cup bore and compare to manufacturer specifications.

STEP 3

Inspect bearing cups and cones for damage. Bearings should be free from chips, contamination, and signs of excessive wear or excessive heat. Refer to bearing damage analysis literature for identifying possible bearing issues.

STEP 4

Inspect axle spindle bearing journals for any signs of damage or excessive wear. Remove any raised areas or burrs using emery cloth, a file, or other appropriate tool. (See **FIGURE D**)

STEP 5

Journals should be measured and compared with manufacturer specifications.

INSTALLATION STEP 1

Thoroughly clean bearing cups and cones prior to installation. (See **FIGURE E**)

CAUTION: Do not use compressed air to spin bearing rollers as injury may result if cage does not retain the rollers.

STEP 2

Lightly coat the outside of bearing cups with oil. (See **FIGURE F**)

STEP 3

Using a cup driver, carefully drive bearing cups into hub bearing bores. Be sure to drive cup firmly against cup shoulder in hub. (See **FIGURES G and H**)

If a cup driver is not available, a mild steel drift can be used to install bearing cups.

CAUTION: When driving bearing cups, drifts and other tools can damage bearings.

WARNING: NEVER use a bearing cone to drive a bearing cup. This can damage the bearings and cause premature failure.

STEP 4

Use a feeler gauge to check for gaps between cup and shoulder.

STEP 5

Inspect the bearing cups to ensure no damage occurred during installation.

STEP 6

Lubricate bearing cones according to recommended practices and proceed with installation of wheel assembly.

WHEEL BEARING ADJUSTMENT

TMC'S RECOMMENDED WHEEL BEARING ADJUSTMENT PROCEDURE FOR STANDARD SPINDLE NUTS

Proper wheel bearing adjustment is critical to the performance of wheel seals and other related wheel end products. For that reason, we are proud to be a part of TMC's Wheel End Task Force.

We are happy to bring these standards in the form of this technical guide. Working together in this way, STEMCO® helps keep rigs rolling.

The following RP-618A seven-step bearing adjustment recommendation for standard spindle nuts was developed by TMC's Wheel End Task Force. It represents the combined input of manufacturers of wheel end components.

STEP 1

Bearing Lubrication

Lubricate the wheel bearing with clean lubricant of the same type used in the axle sump or hub assembly.

STEP 2

Initial Adjusting Nut Torque

Tighten the adjusting nut to a torque of 200 ft-lbs. while rotating the wheel.

STEP 3

Initial Back-Off

Back the adjusting nut off one full turn.

STEP 4

Re-Torque Adjustment

Re-Torque adjusting nut to 50 ft-lbs while rotating the wheel.

STEP 5

Final Back Off

AXLE TYPE	THREADS PER INCH	FINAL BACK OFF
Steer (Single Nut)	12	1/6 Turn*
	18	1/4 Turn*
Steer (Double Nut)	14	1/2 Turn
	18	1/2 Turn
Drive	12	1/4 Turn
	16	1/4 Turn
Trailer	12	1/4 Turn
	16	1/4 Turn

*Install cotter pin to lock axle nut in position.

STEP 6

Jam Nut Torque

AXLE TYPE	NUT SIZE/ TYPE	TORQUE SPECIFICATIONS
Steer (Double Nut)	Less Than 2 5/8"	200-300 ft-lb
	2 5/8" and Over	300-400 ft-lb
Drive	Dowel-Type Washer	300-400 ft-lb
	Tang-Type Washer	200-275 ft-lb
Trailer	2 5/8" and Larger	200-300 ft-lb
	2 5/8" and Over	300-400 ft-lb

STEP 7

Acceptable End Play

The dial indicator should be attached to the hub or brake drum with its magnetic base. Adjust the dial indicator so that its plunger is against the end of the spindle with its line of action approximately parallel to the axis of the spindle.

Grasp the wheel or hub assembly at the 3 o'clock and 9 o'clock positions. Push and pull the wheel end assembly in and out while oscillating the wheel approximately 45 degrees. Stop oscillating the hub so that the dial indicator tip is in the same position as it was before oscillation began. Read the bearing end play as the total indicator movement.

Measuring Acceptable End Play

- **STEP 1** Using a magnetic base, mount the dial indicator on the spindle end, making sure the hub face is clean and free of gasket material.
- **STEP 2** Adjust the arm of the dial indicator, setting the plunger tip of the indicator on the machined face of the hub at the 12 o'clock position. The plunger should be set-up so that it is parallel to the axis of the spindle. When positioning the indicator tip, ensure that the indicator has adequate range of travel for proper measurement. Set the indicator to zero.
- **STEP 3** Grasp the wheel/hub assembly at the 3 o'clock and 9 o'clock positions. Pull the wheel end assembly outward while oscillating the wheel approximately 45°. While continuing to pull, stop oscillating and read the indicator.
- **STEP 4** Push the wheel assembly inward while oscillating. While continuing to push, stop oscillating and read the indicator.
- **STEP 5** Read bearing end play as total indicator movement.

NOTE: Acceptable end play is .001" to .005" as measured with a dial indicator as per TMC's Recommended Bearing Adjustment Procedure.

DISCOVER® XR / VOYAGER® INSTALLATION INSTRUCTIONS



STEP 1

Remove all burrs from the hub bore and spindle. Clean and inspect the spindle, threads, and seal shoulder. These areas are to be free of debris, rust, weld splatter, and loose particles or build up of any type. Thoroughly clean the entire wheel cavity.

NOTE: DO NOT apply any sealant to the spindle shoulder. Apply a light coat of lubricant to spindle surfaces.

STEP 2

Orient the hub such that the inner bearing cup is up, pre-lube the inner bearing and place it into the bearing cup. (See **FIGURE A**)

NOTE: When using grease, pre-pack the inner bearing before placement into the hub.

STEP 3

Place the seal on the recommended STEMCO Installation Tool, with the correct head, so that the words "Air Side" face into the tool. Place the tool (with the seal correctly mounted in the tool head) over the hub bore. Use a 3 to 5 pound hammer to drive the seal into the bore until complete bottoming is assured. Remove Tool. (See **FIGURE B**) Apply a thin layer of lubricant on the ID surface of the seal.

NOTE: DO NOT apply lubricant to the OD of the seal. DO NOT apply sealant to the seal OD or ID.

STEP 4

With the wheel mounted on a wheel dolly, carefully align the seal with the spindle. Gently move the hub/wheel assembly back on the spindle until the seal is completely installed on the spindle shoulder. (See **FIGURE C**) Pre-lube the outer bearing and push it into the bearing cup. Hand tighten the axle nut to hold the outer bearing in place before removing the wheel dolly.

NOTE: When using grease, follow TMC RP631B guideline for proper hub fill. Pre-pack the outer bearing before placement into the hub.

STEP 5

Tighten to 200 ft-lbs and rotate the wheel several times. Then back off nut one full turn. Install the axle fastener per the manufacturer's recommendations and TMC requirements for proper installation and endplay. (See **FIGURE D**)

STEP 6

STEER AND TRAILER AXLES: Install the hub cap with a new gasket and fill the cavity with lubricant to the proper level.

DRIVE AXLES: Install drive axle using a new gasket. Be sure the differential oil is high enough (see manufacturer's recommendation) to ensure oil flow through the axle to the hub. It is recommended to jack one side up and then the other to start lubricant flow.

ALL APPLICATIONS: Make sure the breather plug is clear. Recheck fill level (steer and trailer applications).



DISCOVER XR®

Voyager®

GUARDIAN® HP INSTALLATION INSTRUCTIONS

STEP 1

Remove all burrs from the hub bore and spindle. Thoroughly clean the entire wheel cavity. Apply a thin layer of No. 2 sealant to the O.D. of the spindle shoulder. Place the seal assembly on the spindle so the words "OIL BEARING SIDE" are exposed to the oil. (See **FIGURE A**) Clean and inspect the spindle, threads, and seal shoulder. These areas are to be free of debris, rust, weld splatter, and loose particles or build up of any type.

WARNING: DO NOT INSTALL THE SEAL INTO THE HUB BORE.

STEP 2

Using the recommended STEMCO Universal Axle Tool, drive the seal assembly on until the tool bottoms against the shoulder. (See **FIGURE B**) Make sure the ring is flush with the axle shoulder. Ensure seal fully contacts the wear ring flange. Wipe away any excess sealant.

STEP 3

Dip the inner bearing in oil and place on the spindle.

NOTE: The O.D. of the seal must be coated with a thin coat of the same lubricant used in the hub.

NOTE: When using grease, pre-pack the inner bearing before placement on the spindle.

STEP 4

With the hub mounted on a wheel dolly, carefully push the hub onto the spindle until it contacts the seal. (See **FIGURE C**) Dip the outer bearing in oil and place it on the spindle. Hand tighten the axle nut to hold the outer bearing in place before removing the wheel dolly.

NOTE: When using grease, follow TMC RP631B guideline for proper hub fill. Pre-pack the outer bearing before placement into the hub. Clean the back side of the wheel end if excess lubricant is present.

STEP 5

Tighten to 200 ft-lbs and rotate the wheel several times. Then back off nut one full turn. (See **FIGURE D**) Install the axle fastener per the manufacturer's recommendations and TMC requirements for proper installation and endplay.

STEP 6

STEER AND TRAILER AXLES: Install the hub cap with a new gasket and fill the cavity with lubricant to the proper level.

DRIVE AXLES: Install drive axle using a new gasket. Be sure the differential oil is high enough (see manufacturer's recommendation) to ensure oil flow through the axle to the hub. It is recommended to jack one side up and then the other to start lubricant flow.

ALL APPLICATIONS: Make sure the breather plug is clear. Recheck fill level (steer and trailer applications).

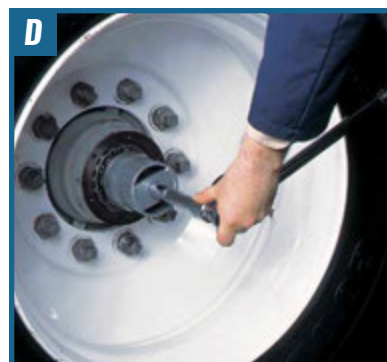

GRIT GUARD® SEAL INSTALLATION INSTRUCTIONS

STEP 1

Remove all burrs from the hub bore and spindle. Clean and inspect the spindle, threads, and seal shoulder. These areas are to be free of debris, rust, weld splatter, and loose particles or build up of any type. Thoroughly clean the entire wheel cavity. Apply a thin layer of No. 2 sealant to the O.D. of the spindle shoulder. Place the axle ring on the spindle.

STEP 2

Using the recommended STEMCO Axle Tool, drive the axle ring on until the tool bottoms against the shoulder. Make certain the axle ring is flush with the shoulder. Wipe away any excess sealant. (See **FIGURE A**)

STEP 3

Orient the hub such that the inner bearing cup is up, pre-lube the inner bearing and place it into the bearing cup. (See **FIGURE B**)

NOTE: When using grease, pre-pack the inner bearing before placement into the hub.

STEP 4

Apply a thin layer of No. 2 sealant to the OD of the seal and position the seal in the hub. Using the recommended STEMCO Universal Hub Tool, held in a vertical position, drive the seal into the seal bore until it is bottomed out. Check the clearance between the bearing cone and seal (at least 1/32nd is required). (See **FIGURE C**)

STEP 5

With the wheel mounted on a dolly, carefully align the bore with the spindle. Gently push the wheel assembly on to the spindle to the proper position. Pre-lube the outer bearing and push it into the bearing cup. Hand tighten the axle nut to hold the outer bearing in place before removing the wheel dolly. (See **FIGURE D**)

NOTE: When using grease, pre-pack the outer bearing before placement into the hub. Follow TMC RP631B guideline for proper hub fill.

STEP 6

Install the axle fastener per the manufacturer's recommendations and TMC requirements for proper installation and endplay. (See **FIGURE E**)

STEP 7

STEER AND TRAILER AXLES: Install the hub cap with a new gasket and fill the cavity with lubricant to the proper level.

DRIVE AXLES: Install drive axle using a new gasket. Be sure the differential oil is high enough (see manufacturer's recommendation) to ensure oil flow through the axle to the hub. It is recommended to jack one side up and then the other to start lubricant flow.

ALL APPLICATIONS: Make sure the breather plug is clear. Recheck fill level (steer and trailer applications).

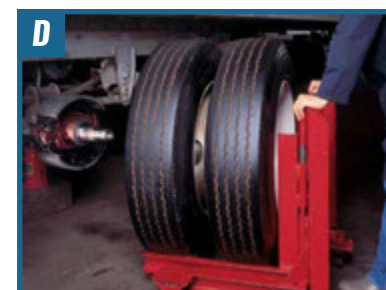

AUTO-TORQ® INSTALLATION INSTRUCTIONS

This procedure will consistently set the bearings in an optimum state of pre-load per SAE J2535. Endplay reading should be 0.000" And the wheel end assembly should spin freely.

Auto-torq® should not be used with any systems that require the use of a spacer.

INSTALLATION PROCEDURE

Prepare hub assembly and spindle prior to installing Auto-Torq. The inner bearing and seal should be properly installed in a cleaned and prepared hub. LUBRICATE the ID of the seal. The spindle needs to be cleaned and threads need to be inspected for defects.

NOTE: Any damage to the threads may affect the ability of the Auto-Torq to fully seat the bearings. Be sure to inspect the threads of the spindle and always verify the installation with a dial indicator.

STEP 1

After docking the hub on a clean prepared spindle, insert the outer bearing and thread the fastener on by hand.

STEP 2

With a breaker bar (or torque wrench set to at least 100 ft-lbs), tighten the fastener until you hear a prominent/distinct "clicking" or "ratcheting" noise.

- This feedback indicates that the fastener is limiting. You may hear/feel more subtle "clicking" prior to this more prominent limiting point that is caused by the locking mechanism starting to engage. In this case, continue to tighten until the feedback is much more pronounced to ensure that the fastener is limiting properly. NOTE: You cannot "overtighten" this fastener, so if there is any doubt, continue to tighten to confirm the fastener has reached the limiting point.
- The fastener will limit on its own before 75ft-lbs, so using a torque wrench set to at least 100 ft-lbs will ensure the wrench performs essentially like a breaker bar and allow the fastener to reach its designed limit point.
DO NOT use an impact gun to tighten this fastener as it may damage the internal components.

STEP 3

With hub or hub/drum only:

- Tighten the fastener (1) full rotation past this limiting point, then spin the hub at least (1) full rotation. Rotating the hub is necessary to help seat the bearings.
- Repeat the above step until you have tightened the fastener by 5 full rotations past its initial limiting position, rotating the hub between each turn of the fastener. Do NOT back off the axle fastener.

With hub/drum/wheels:

- Tighten the fastener (5) full rotations past this limiting point while the wheel is rotating. Do NOT back off the axle fastener.

WARNING

Failure to follow this instruction could cause the wheel to come off and cause bodily injury.

TOOLS REQUIRED FOR INSTALLATION

AUTO-TORQ® PART NO.	TOOL SOCKET (3/4" DRIVE)
TRAILER AXLE FASTENER	
480-4723 / 480-4723-XR	120 mm 8-point OTC # 1961M
480-4743 / 480-4743-XR	3 7/8" 8-point OTC#1913

INSPECT THE INSTALLATION

STEP 1

Inspect keyway tang to ensure it does not contact the bottom of the keyway. If contact exists, immediately notify your STEMCO representative.

STEP 2

Upon completion of installation ensure the wheel-end rotates freely.

STEP 3

Measure and record endplay in the wheel-end with a dial indicator.

- Endplay should be 0.000" for all units assembled with the Auto-Torq fastener. This is normal, as these wheel ends will be set in slight preload.
- Endplay greater than 0.001" indicates an assembly is not seated properly. Remove the wheel end and inspect components prior to reassembly. Notify STEMCO if this persists.
- The dial indicator should be attached to the hub with its magnetic base.
- Adjust the dial indicator so that its plunger is against the end of the spindle with its line of action approximately parallel to the axis of the spindle.
- Grasp the wheel/hub assembly at the 3 o'clock and 9 o'clock positions.
- Pull the wheel end assembly outward while oscillating the wheel approximately 5°.
- While continuing to pull, stop oscillating and read the indicator. (Note position of dial indicator.)
- Push the wheel assembly inward while oscillating. While continuing to push, stop oscillating at same position as it was before in the pull direction and read the indicator.
- Read bearing end play as total indicator movement.

CAUTION

For wheel bearing adjustments on manually adjusted wheel ends, the optimum condition for measuring end play is with the tires/wheels and brake drum removed from the hub. Fleets or technicians that measure end play with the tires/ wheels and brake drum mounted to the hub should be aware that end play readings are more difficult to obtain and that all braking systems (drum or disc) should be backed off to the point that the brake shoes or pads do not create false end play readings.

ZIP-TORQ® INSTALLATION INSTRUCTIONS

TOOLS REQUIRED FOR INSTALLATION

ZIP-TORQ® PART NO.	TOOL SOCKET (3/4" DRIVE REQUIRED)	OTC PART NO.
TRAILER AXLE FASTENER		
400-4723	4-1/8" Six Point	1915
400-4743	3-1/4" Six Point	1908
400-4973	4" Six Point	1914
STEERING AXLE FASTENER		
400-4836	2-1/8" Six Point	1976
400-4837	2-1/8" Six Point	1976
400-4864	2-7/8" Six Point	
400-4865	2-7/8" Six Point	
DRIVE AXLE FASTENER		
400-4904	3-1/2" Six Point	
400-4973	4" Six Point	1914

NOTE: Ford application 12,000 lbs. SIFCO Steer Axle requires OEM inner washer to be installed prior to installation of Zip-Torq® nut system.

Do not use power or air tools during installation of Zip-Torq.

STEP 2

Thread the Nut Onto the Axle

Thread the nut onto the axle until hand tight.

STEP 2

Seat the Bearing

With wheel hub assembly:

- Using a torque wrench:
 - Tighten the nut to 200 ft-lb. Spin the wheel hub assembly at least one full rotation.
 - Tighten the nut to 200 ft-lb. Spin the wheel hub assembly at least one full rotation.
 - Tighten the nut to 200 ft-lb. Spin the wheel hub assembly at least one full rotation.
- Back the nut off one full rotation.

STEP 3

Adjust the Bearing

With wheel hub assembly:

- Using a torque wrench:
 - Tighten the nut to 100 ft-lb. Spin the wheel hub assembly at least one full rotation.
 - Tighten the nut to 100 ft-lb. Spin the wheel hub assembly at least one full rotation.
 - Tighten the nut to 100 ft-lb. Spin the wheel hub assembly at least one full rotation.
- Back the nut off one face mark (according to chart).

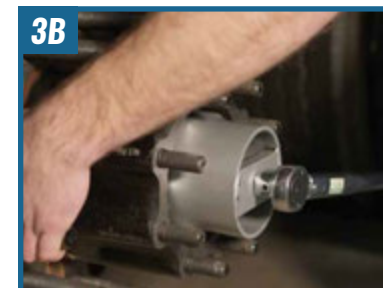
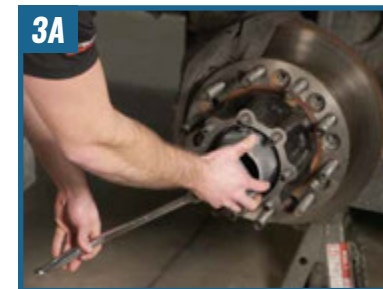
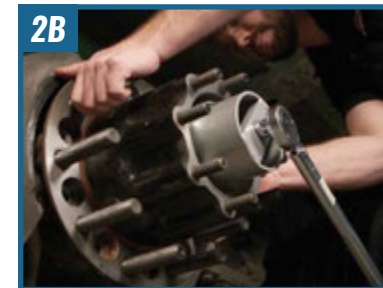

ZIP-TORQ® INSTALLATION INSTRUCTIONS

FINAL BACK OFF

PART NUMBER	BACKOFF
TRAILER AXLE NUT	
400-4723	1/8 turn
400-4973	
TRAILER AXLE NUT	
400-4743	1/4 turn
STEERING SPINDLE NUT	
400-4836	1/4 turn
400-4864	
400-4865	
STEERING SPINDLE NUT	
400-4837	1/3 turn
DRIVE AXLE NUT	
400-4904	1/8 turn
400-4973	

STEP 4

Inspect the Installation

Failure to follow this instruction could cause the wheel to come off and cause bodily injury.

STEP 5

Acceptable End Play

The dial indicator should be attached to the hub or brake drum with its magnetic base. Adjust the dial indicator so that its plunger is against the end of the spindle with its line of action approximately parallel to the axis of the spindle.

Grasp the wheel or hub assembly at the 3 o'clock and 9 o'clock positions. Push and pull the wheel-end assembly in and out while oscillating the wheel approximately 45 degrees. Stop oscillating the hub so that the dial indicator tip is in the same position as it was before oscillation began. Read the bearing end-play as the total indicator movement.

***Acceptable end-play is .001" – .005"**

For single nut self-locking systems, consult manufacturers' specifications. STEMCO assumes no responsibility for other manufacturers' bearing warranty.

WARNING

Failure to follow this instruction could cause the wheel to come off and cause bodily injury. STEMCO axle fasteners are sold as an assembly with the keeper in place. DO NOT attempt to place the nut on the spindle or tighten or loosen the nut on the spindle while the keeper is installed inside the nut. Doing so may deform the keeper and allow the nut to unthread during operation. Spindle thread damage could also occur, leaving the axle unusable.

DO NOT bend or manipulate keyway tang in any way. Doing so may cause the tang to break off in service. Failure to back off the axle fasteners on non pre-adjusted systems will cause the bearings to run hot and be damaged.

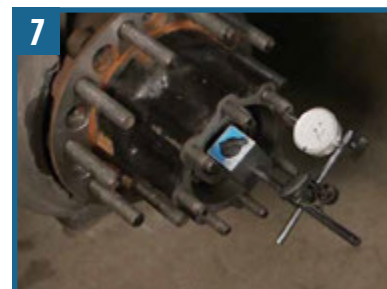
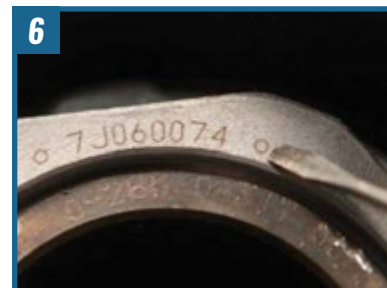

CAUTION

For wheel bearing adjustments on manually adjusted wheel ends, the optimum condition for measuring end play is with the tires/wheels and brake drum removed from the hub. Fleets or technicians that measure end play with the tires/wheels and brake drum mounted to the hub should be aware that end play readings are more difficult to obtain and that all braking systems (drum or disc) should be backed off to the point that the brake shoes or pads do not create false end play readings.

PRO-TORQ® INSTALLATION INSTRUCTIONS

STEP 1

Remove the Keeper From the Nut

Use a small screwdriver to carefully pry the keeper arm from the undercut groove on each side until the keeper is released.



STEP 2

Thread the Nut Onto the Axle

Thread the nut onto the axle until hand tight against the bearing.



STEP 3

Seat the Bearing

With wheel hub assembly:

- Using a torque wrench:
 - Tighten the nut to 200 ft-lb. Spin the wheel hub assembly at least one full rotation.
 - Tighten the nut to 200 ft-lb. Spin the wheel hub assembly at least one full rotation.
 - Tighten the nut to 200 ft-lb. Spin the wheel hub assembly at least one full rotation.
- Back the nut off one full rotation.



STEP 4

Adjust the Bearing

With wheel hub assembly:

- Using a torque wrench:
 - Tighten the nut to 100 ft-lb. Spin the wheel hub assembly at least one full rotation.
 - Tighten the nut to 100 ft-lb. Spin the wheel hub assembly at least one full rotation.
 - Tighten the nut to 100 ft-lb. Spin the wheel hub assembly at least one full rotation.
- Back the nut off one face mark (according to chart).



STEP 5

Install the Keeper

Orange side facing out:

- Insert the keeper tab into the undercut groove of the nut and engage the keyway tang in the axle keyway. Insert keeper tab with the orange side facing out.
- Engage the mating teeth.
- Compress and insert the keeper arms, one at a time, into the undercut groove with a screwdriver.

For Steering Spindle Nut:

448-4836, 448-4839, 448-4840, 448-4863, 448-4864, and 448-4865

- Align the flat of the keeper with the milled flat on the spindle and insert the single keeper tab into the undercut groove of the nut. Insert keeper tab with the orange side facing out.
- Engage the mating teeth.
- Compress and insert the keeper arms, one at a time, into the undercut groove with a screwdriver.



NOTE: Recommended practice is to replace the keeper each time the Pro-Torq nut assembly is removed for maintenance purposes.

STEP 6

If the inner tang does not line up with the keyway, back the nut off slightly until it does. Using a small screwdriver, compress and insert the keeper arms, one at a time, into the undercut groove. The orange painted side of the keeper must be facing out.

STEP 7

Inspect the Installation

Failure to follow this instruction could cause the wheel to come off and cause bodily injury. Make sure that the keeper tab and keeper arms are fully seated into the undercut groove.

(Continued Next Page)

PRO-TORQ® INSTALLATION INSTRUCTIONS

STEP 8

Inspect keyway tang to insure it does not contact the bottom of the keyway. If contact exists, immediately notify a STEMCO representative.

This procedure will consistently produce a bearing setting of 0.001" to 0.003" end play.

STEP 9

Acceptable End Play

The dial indicator should be attached to the hub or brake drum with its magnetic base. Adjust the dial indicator so that its plunger is against the end of the spindle with its line of action approximately parallel to the axis of the spindle.

Grasp the wheel or hub assembly at the 3 o'clock and 9 o'clock positions. Push and pull the wheel-end assembly in and out while oscillating the wheel approximately 45 degrees. Stop oscillating the hub so that the dial indicator tip is in the same position as it was before oscillation began. Read the bearing end-play as the total indicator movement.

*Acceptable end-play is .001" – .005"

For single nut self-locking systems, consult manufacturers' specifications. STEMCO assumes no responsibility for other manufacturers' bearing warranty.

WARNING

Failure to follow this instruction could cause the wheel to come off and cause bodily injury. STEMCO axle fasteners are sold as an assembly with the keeper in place. DO NOT attempt to place the nut on the spindle or tighten or loosen the nut on the spindle while the keeper is installed inside the nut. Doing so may deform the keeper and allow the nut to unthread during operation. Spindle thread damage could also occur, leaving the axle unusable.

DO NOT bend or manipulate keyway tang in any way. Doing so may cause the tang to break off in service. Failure to back off the axle fasteners on non pre-adjusted systems will cause the bearings to run hot and be damaged.

FINAL BACK OFF

PART NUMBER	BACKOFF
TRAILER AXLE NUT	
447-4723	
447-4724	1/8 turn
449-4973	
TRAILER AXLE NUT	
447-4743	1/4 turn
STEERING SPINDLE NUT	
448-4836	
448-4838	
448-4839	1/4 turn
448-4863	
448-4864	
448-4865	
STEERING SPINDLE NUT	
448-4837	1/3 turn
448-4840	
DRIVE AXLE NUT	
449-4904	
449-4973	1/8 turn
449-4974	
449-4975	

CAUTION

For wheel bearing adjustments on manually adjusted wheel ends, the optimum condition for measuring end play is with the tires/wheels and brake drum removed from the hub. Fleets or technicians that measure end play with the tires/ wheels and brake drum mounted to the hub should be aware that end play readings are more difficult to obtain and that all braking systems (drum or disc) should be backed off to the point that the brake shoes or pads do not create false end play readings.

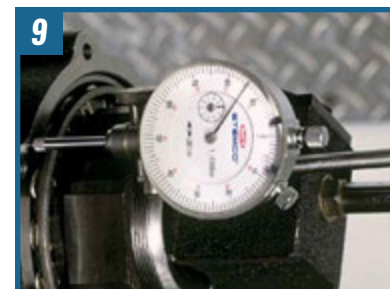
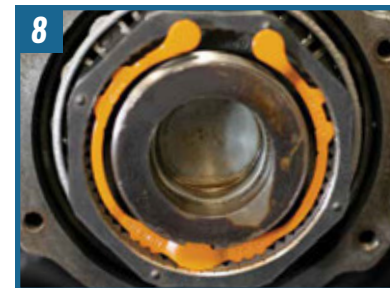
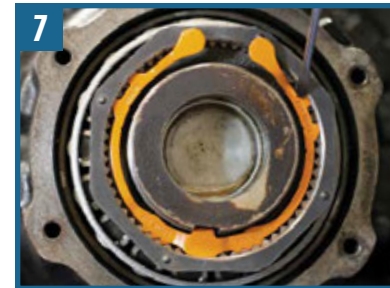
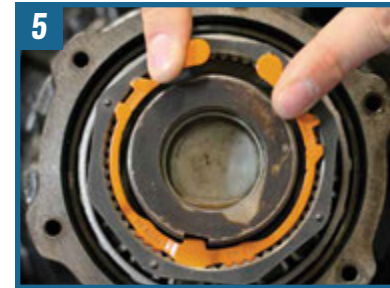

HUB CAP INSTALLATION AND TROUBLESHOOTING

The hub cap endures constant physical abuse from the elements and internal factors that can affect its characteristics both visually and functionally. The TQMSM Manual will provide helpful information about installation and lubrication, as well as help in troubleshooting problems. Additionally, examples of potential hub cap failures are pictured in the Failure Analysis section.

Proper Hub Cap Installation Procedures

STEP 1

Check the mounting surface of the hub, making sure to clean off old gaskets and sealant. Also, check for any burrs or imperfections that might prevent a proper gasket seal.

STEP 2

Make sure all components are free of any dirt or grit.

STEP 3

Always install the hub cap with a new gasket.

STEP 4

Split washers are recommended to lock the flange bolts in place.

STEP 5

Initially hand tighten the hub cap (see bolt tightening sequence below) and finally torque to the recommended specification as noted on page 34.

STEP 6

For the threaded Pro-Par caps, lightly lubricate the threads and O-ring and install the hub cap. Refer to the torque specifications on Page 34 for the recommended torque value for threaded hub caps.

STEP 7

For oil applications, fill to the recommended level and re-check after the lube has had adequate time to establish its final level.

Window Kit Replacement Procedures

STEP 1

Remove the old window ring using a #8 Torx driver.

STEP 2

Thoroughly clean the hub cap and window ring leaving the window ledge free of oil and the mounting surface of the window ring clean and free of any old gasket material.

STEP 3

Place the new window gasket in the hub cap casting, and insert the new window with the window ring and window ring gasket in place.

STEP 4

It is recommended that screws be replaced with new ones. Once the screws have been started and pulled down, begin tightening with a cross hatch pattern to evenly distribute the load. Refer to the Torque Specifications chart on Page 34 for the proper torque. It is recommended that hand tools be used for this procedure, as power tools may over-torque the screws and damage the threads.

STEP 5

The hub cap is now ready for installation.

RECOMMENDED BOLT TIGHTENING SEQUENCE

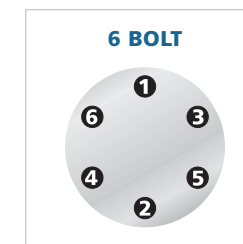
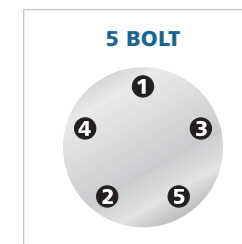
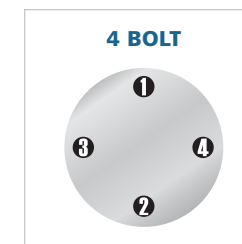

HUB CAP INSTALLATION AND TROUBLESHOOTING

FREQUENTLY ASKED QUESTIONS

Q. Should the hub cap be packed with grease?

A. A small amount of grease may be added to the hub cap before installation. Do not cover the vent mechanism with grease. For additional information on lubrication fill procedures for hub caps, refer to TMC publication RP 631.

Q. How tight should the flange bolts be?

A. Refer to the Hub Cap Torque Specifications below.

Q. Is it OK to use an impact tool to mount the hub cap?

A. It is suggested that hub cap bolts be tightened with hand tools to prevent possible warping or breakage of the hub cap flange. Refer to the Torque Specifications below for the recommended torque value.

Q. Is venting required for all applications?

A. It is suggested that the wheel assembly be vented to allow the hub to vent pressure and relieve vacuum when using oils and synthetic greases. Only with heavy packing grease will the wheel end properly operate without venting.

Q. Why do my hub caps have a build-up on the inside of the sight glass?

A. This build-up is a slow process caused by the additives present in some lubricants. Removal is impossible; however, replacement window kits are available.

TROUBLESHOOTING GUIDE	
PROBLEM	POSSIBLE SOURCES OR CAUSES
Water Contaminated/ Milky Oil	High pressure washing, flooded loading docks
Bulged/Melted Windows	Check for low lube level, high heat caused from improperly adjusted bearings, high heat caused from improperly adjusted brakes.
Leaking Gaskets	Improper torque of flange bolts, gouged mounting surface (hub cap flange/hub face), no gasket, reuse of gasket.
Leakage from Red Fill Plug	Make sure the oil level is not in an overfilled condition, and check the vent hole to make certain it is not plugged. High heat and resulting pressure may also contribute to leakage.

HUB CAP TORQ SPECS			
THREADED HUB CAPS			
Part No.			Torq
XXX-4075			100 ft/lbs
340-4975			50-60 ft/lbs
340-4976			50-60 ft/lbs
640-0003			50-60 ft/lbs
HUB CAP COMPONENTS			
Part No.	Type	Torq	
359-6032	#8 Torx Screw	18-23 in/lbs	
359-5984	3/8" Mag Plug	5-9 ft/lbs	
359-5985	3/8" Pipe Plug	5-9 ft/lbs	
Hub Cap Mounting Bolts			
Size	Torq	Size	Torq
1/4"	8-12 ft/lbs	5/8"	22-26 ft/lbs
5/16"	12-16 ft/lbs	3/4"	24-28 ft/lbs
3/8"	16-20 ft/lbs	7/8"	26-30 ft/lbs
7/16"	18-22 ft/lbs	6MM	8-12 ft/lbs
1/2"	20-24 ft/lbs	8.5MM	12-16 ft/lbs

DATATRAC® PRO INSTALLATION INSTRUCTIONS

HOW IT WORKS

DataTrac Pro is an advanced mileage counter that relies on Earth's gravity for counting wheel revolutions. The DataTrac Pro unit monitors its orientation to Earth's gravitational pull and uses this reference to recognize and count revolutions.



Install DataTrac Pro on wheel end.



Display turns on when the vehicle is at rest.



Display turns off when vibration is detected (vehicle moving) to conserve energy.



LIFE mode shows mileage without tenths.



TRIP mode shows mileage with tenths and TRIP icon.



REV Mode shows RPM or RPK unit Programmed for.

PROGRAMMING THE UNIT

DISTRIBUTION OR END USER WITH A PROGRAMMER

The unit is shipped from the factory with a Revs/Mile value of zero. Dashes (- - -) on the display indicate that the unit has NOT been programmed. It MUST be programmed before it is installed on a wheel end (The DataTrac Pro distributor should have a programmer or can sell a programmer).

THE PROGRAMMER CAN SET THE DATATRAC PROS:

STEP 1

The Revolutions/Mile (or per Km)

Use Stemco's catalog to determine the Revolutions/Mile for each Tire Make/Model.

STEP 2

Distance Unit of Measure

Miles or Km (Life miles only or including Trip Miles)

STEP 3

Mileage Preset

Set the mileage to match the current mileage of the vehicle the unit will be mounted to.

When programming is complete, (as indicated on the programmer screen) immediately lift the DataTrac PRO up and confirm the display shows the correct Tire Revolutions (shown as "REV###" on the screen). If not, repeat the programming.

The DataTrac Pro can be programmed/reprogrammed as many times as desired until there is approximately 2 miles on the unit.

INSTALLING THE UNIT

Install the DataTrac PRO unit using the appropriate STEMCO bracket and hardware. The nut furnished with the unit is a locking nut and must NOT be torqued over 15-ft lbs.

READING THE DISPLAY

The display will turn on when the vehicle is at rest. Numbers will automatically orient to read upright. This is also indicated by the icon display, e.g. mile, km, acre. The mileage reading is always in the same direction as the icon.

In order to conserve power the display turns off at any time a vibration is detected. This means that the display will be off while the vehicle is moving. As soon as all vibration or motion stops the display will reactivate in about 5 seconds.

DISPLAY MODES

The DataTrac Pro unit comes equipped with three display modes: LIFE and TRIP (if programmed), and REV. To toggle the display between LIFE, TRIP and REV Modes, cover the round bubble on the face of the unit for at least 1 second, and then uncover it. If the unit is in bright sunlight, the bubble may have to be covered to block more light from reaching the sensor. TRIP mode is displayed with tenths resolution and is indicated by display of the TRIP icon (only if unit is programmed for TRIP).

To reset the TRIP display, toggle between LIFE, TRIP and REV Modes 5 times, quickly. Note that the unit cannot toggle faster than every 1.5 seconds. To view the revolutions of the unit simply repeat the process that is used to view trip and then a screen that shows (REV XXX) will show up. The XXX is the number of revolutions per KM or MILE that the unit is programmed for. On units without TRIP there are only two screens, all others have three screens (LIFE, TRIP, and REV). As with the TRIP mode the unit will return to the mileage after 10 seconds if left in the revolutions screen.

CERTIFICATIONS

This unit complies with European EMI (CE) regulations as noted on front cover by the E11 marking.

PRODUCT LIMITATIONS

This unit should not be used as a rotating shaft counter for machinery, unless the machine shaft rotates slower than 1250 RPM and has a slow acceleration profile similar to a wheel end. At all times the unit should rotate about an axis perpendicular to gravitational forces.

This unit contains a Lithium-Thionyl Chloride battery and should be disposed of according to local regulations. The battery contains less than 1 gram of lithium and is therefore classified as a non-hazardous product. Lithium-Thionyl Chloride batteries contain no poisonous materials and do not present environmental hazards when properly disposed of.

DataTrac
PRO

DATATRAC® SVT INSTALLATION INSTRUCTIONS

STEP 1

DOWNLOAD THE APP

Search for and download the STEMCO Fleet Manager App on your Android or Apple device.

STEP 2

PROGRAMMING THE UNIT

Launch the application by pressing the SVT Icon. You will then need to provide approval for the application to access Bluetooth and GPS and acknowledge the Terms of Use and Privacy Policy. Next, you will see the below screen. If you plan to use STEMCO Web Portal or Sync Server Solution then setup your account and login BEFORE programming your SVT. If you don't plan to use either of the STEMCO cloud solutions then you can Select **No Sync SVT Programmer**.

IMPORTANT: Before programming a DataTrac SVT, it is necessary to determine which of the three syncing options will be used for the fleet. The three options are:

WEB PORTAL – Intended for all size fleets that need one or more of the advanced features offered by this solution (see table on the right).

SYNC SERVER – Intended for single location smaller fleets that only need basic mileage collection using one or more cell phones. Basic user management is included along with fleet locked security for reprogrammable DataTrac SVT.

NO SYNC – Intended for those that only use the STEMCO Fleet manager application for programming ONLY (will not utilize the Sync Server or Web Portal cloud records syncing solutions); applications like programming Tamperproof DataTrac SVTs that will be installed on vehicles that are using a third party telematics solutions or for Reprogrammable “one off” applications where reprogramming security is not a concern.

STEP 3

Selecting **Web Portal Solution** will take you to this screen. You can either enter your login information or Request a Web Portal Account. If you request an account, you will be taken to a form that you will need to fill out.

STEP 4

Selecting **Sync Server Solution** will take you to this screen where you will see three options. To join an existing company, you will need an invite code and will need to fill out a form. To create a new company, you will be directed to a screen to fill out a form. Finally, you may also sign in to an existing company using your email address and password.

FEATURE	NO SYNC	SYNC SERVER SOLUTION	WEB PORTAL SOLUTION
Cell Phone App Compatible	✓	✓	✓
Software Fees	Free	Free	Trial period followed by paid subscription
User Management Model	None	Basic, cell phone app based	Full, user management control on web portal
Security Model	None	Basic	Enhanced
Reprogrammable DataTrac SVT Security Model	None, ANYONE can reprogram DataTrac SVT	Basic, only fleet account app users can reprogram DataTrac SVT	Enhanced, only fleet account app users can reprogram DataTrac SVT
Multi-User Data Syncing	✓	✓	✓
User Permission Tri-Level Controls (Admin, Power, Base)	X	✓	✓
Multi-Terminal Support	X	X	✓
Gate Reader Compatible	X	X	✓
Historical Record Retention	X	X*	✓ (5 years)
Web Portal Interface	X	X	✓
Business System API Integration Available	X	X	✓
Fuel and Fluids Logging	X	X	✓

STEP 5

Once you have logged in to Sync Server, you can select the three bars on the top left corner to access the menu. From here you can select Manage User to invite users by entering their email address. They will be sent a code, which will be entered when they select **Join an existing company**.

NOTE: Manager user is only available in the Sync Server Solution.

STEP 6

You will see a list of nearby DataTrac® SVT™ devices. To identify the device you'd like to program, place the device horizontally with the screen facing up. This will move the device to the top of the list. Make sure your other devices are placed vertically. This will allow the horizontally aligned device to be first on the list.

NOTE: The serial number that shows up on the app is also laser marked on the front face of the DataTrac® SVT™. You will be able to identify the device that way as well.

STEP 7

After you have identified the device you'd like to program, click into the device and select **Program DataTrac® SVT™** at the bottom of the screen.

STEP 8

Then press **Program DataTrac® SVT™**.

NOTE: If you program more than one sensor choose a unique vehicle name.

STEP 9

You will then be taken to this screen while the programming occurs. This will take about 20 seconds.

STEP 10

After the programming is complete, you will be taken to the Vehicle Details screen. From here, you can press the back button to return to the main screen.

NOTE: The DataTrac SVT will show the REV ### programmed for about 2 seconds and then display the preset life Distance on the screen.

NOTE: The light sensor bubble has no functionality in the DataTrac SVT.

STEP 11

Once the device has been programmed, it will show up in the Paired Vehicles list.

STEP 12

If you want to change any of the programmable parameters, select the vehicle and press the “Reprogram DataTrac®” at the bottom on the screen.

*Customer can email real-time snapshots of information to a csv spreadsheet compatible file.

WHEN IT COMES TO TRAINING WE HOLD OURSELVES TO A HIGHER STANDARD

TQMSM

TOTAL QUALITY MAINTENANCESM

STEMCO is committed to “Making the Roadways Safer” and increased customer value. We recognize the importance of providing customers with detailed product information, installation procedures and failure analysis. This TQMSM Manual was designed for this purpose, to assist in achieving a higher standard of performance within your operation.

What can TQM provide for your company?

A wheel end is not a collection of parts functioning independently; it is a system of interacting components. Specifically, the hub seal, axle fastener, hub cap, bearings, and lubricant play an important role in the overall performance of the wheel end. Each component is interrelated and its performance affects the total system. Using STEMCO parts with fluid lubrication, your wheel end components will not only provide optimum individual performance, they will, together, form a world-class wheel end system.

Quality Components Working as an Integral Unit Supported by Trained Professionals.

As a result of more than five decades of experience in the trucking industry, STEMCO has accumulated product and process knowledge of wheel end systems that will benefit all maintenance professionals. TQM demonstrates how STEMCO products, designed to perform with standard hub and axle configurations combined with sound assembly procedures, can result in exceptional wheel end performance.

As trucking technology has advanced, STEMCO has responded to the needs of the industry. At STEMCO, state-of-the-art equipment duplicates exact road conditions to test seal products and to insure their durability and performance. This TQMSM Manual is designed to maximize your investment in today's technologically advanced components, thereby helping the transportation industry achieve the goal of Total Quality Maintenance.

To request training on any or all of these products, contact your local STEMCO Regional Sales Manager.

STEERING PRODUCTS TRAINING

- King pin replacement for QwikKit® and PlusKit®
- Complete break down and rebuild training
- Troubleshooting and inspection

STEMCO STEERING PRODUCTS.

WHEEL END PRODUCTS TRAINING

- Techniques to make seals last longer
- Single nut and double nut
- Adjustment procedures
- Proper fill rates
- Troubleshooting and inspection

STEMCO WHEEL END.



DataTrac SVT™

STEMCO®

UNITED STATES | 800-527-8492 | 903-758-9981

300 Industrial Drive
Longview, Texas 75602 | US

4641 Industrial Drive
Millington, Michigan 48746 | US

CANADA | 877-232-9111 | 905-206-9700
1020 Lorimar Drive
Mississauga, ON L5S 1R8 | Canada

MEXICO | 444-804-1736

Eje Central Sahop No 215, Zona Ind
San Luis Potosi SLP 78395 | Mexico

AUSTRALIA, NEW ZEALAND, PAPUA

011-61-2-9793-2599
2/198 Walters Road
Arndell Park NSW 2148 | Australia



STEMCO®

Making the Roadways Safer®

— An ENPRO Company —

Learn more at stemco.com

STEMCO, Defender ESP, Discover XR, Grit Guard, Guardian, Voyager, Platinum Performance System, Sentinel, Defender, Pro-Torg, Zip-Torg, Hubodometer, DataTrac Pro, TQM and STEMCO Wheel End are all trademarks of STEMCO Products Inc.
© 2026 STEMCO Products Inc. | Part No. 574-0140 | Rev. 6/26