

**STEMCO®**



# STEMCO KAISER™ STEERING COMPONENTS CATALOG



**STEMCO®**  
A Higher Standard of Performance.™

**Making the Roadways Safer®**

an EnPro Industries company

# STEMCO SUSPENSION PRODUCTS™

At STEMCO® we engineer advanced commercial vehicle solutions and create exceptional customer experiences in our passion to make the roadways safer. STEMCO Kaiser is a product line of STEMCO, and manufacturers superior quality solutions for the commercial vehicle industry. STEMCO Kaiser has the industry's most extensive offering of steering knuckle king pin kits, spring pins and bushings for leaf springs and shackles; as well as pre-sized, hardened sleeves to repair worn axle eyes.

## STEMCO KAISER™ KING PIN KITS

Kits contain all necessary components to complete a king pin repair. STEMCO Kaiser king pin kits offer three kit options to meet all customer needs.

**QwikKit®** — No need to ream, ease of installation, and 300% better lubrication with extreme long life. QwikKit is the original grease grooved King Pin and spiral steel bushing design. Always use the STEMCO Kaiser QwikKit.

**PlusKit®** — Pre-sized bronze bushing kit, which allows for the lowest total repair cost in the market. Less down time and labor costs due to the bushing's no ream feature. Insist on PlusKits the no ream bronze bushing product that does not compromise quality.

**Econo Kit™** — Top quality bronze bushings and quality king pins allow for a customizable individual fit, are competitively priced and offers consistent components in every kit.

## STEMCO KAISER SPRING PINS AND BUSHINGS

Features include grease grooved spring pins and bushing assemblies with sealed bushing technology to keep grease in and dirt out. When used together, the grooved pin and sealed bushing assemblies will provide up to three times the life compared to the OE spring pins and bushings. This combination offers; easier greasing and ease of installation when used with our unique install tools.

**BSP™** — Spring Pins - STEMCO Kaiser spring pins can be used with any bushing. The only grease grooved pin in the industry creating more grease capacity.

**BSA™** — Bushings — STEMCO Kaiser QwikKit spiral steel bushing with sealed bushing technology provides ease of installation and the longest life possible.

**BSL** — Bushings — STEMCO Kaiser LUBRAflex® bushing with hardened wire insert with sealed bushing technology for better lubrication concentration and exceptional life.

**BSG** — Bushings — Generic bronze bushing of highest quality bronze that are available for quality repair.

## STEMCO KAISER APE SLEEVES

Axle bore issues are a common problem when doing a king pin repair and fixing the problem is essential.

STEMCO Kaiser APE sleeves are easy to install and harder than the axle bore to provide extended life. APE sleeves also have the lock pin slots pre-cut for a trouble free installation.

## WHAT MAKES OUR PRODUCTS DIFFERENT?

STEMCO Kaiser has been an industry institution for over 45 years and is known as the premier provider of “no ream” King Pin and Spring Pin solutions. STEMCO Kaiser has a history of providing real world solutions to some of the industry's biggest problems. The QwikKit king pin kit has successfully provided four times the life of traditional king pin kits when used in the after-market. STEMCO Kaiser also offers an industry best technical training and support team, as well as live in shop training sessions.

STEMCO KAISER King Pin Kits, Spring Pins, Bushings, and Axle Sleeves are proudly made in the USA and outperform, outlast and are simpler to install than other products on the market.

The STEMCO website and mobile application offer valuable reference and support tools for the STEMCO Kaiser product line. Please visit [www.stemco.com](http://www.stemco.com) for additional resources and support. We also offer a live tech help-line to help find the right product, call us at **800-527-8492**.



Making the Roadways Safer®

an EnPro Industries company

# CONTENTS ALPHABETICAL BY MAKE

## STEERING KNUCKLE KING PIN KITS

Alliance Axle.....	4
Chevrolet.....	4-5
Clark.....	5
Dodge.....	6
Eagle.....	6
Eaton.....	6
Ford.....	6-9
Freightliner.....	9
FWD.....	9
GMC.....	9-11
Hendrickson.....	11
Hino.....	11
IMT / Ingersoll.....	11
International / Navistar.....	12-14
Isuzu.....	14-15
Kenworth.....	15
KGI.....	15
Kimble Mixer.....	15
Link.....	15
Mack.....	15-16
MAN.....	16
MCI.....	16
Mc Nelius MTM.....	16
Mitsubishi.....	16
New Flyer.....	16
Peterbilt.....	16
Ridewell.....	16
Rockwell / Meritor.....	16-18
Spicer / Dana / Eaton.....	19-21
Sterling.....	21
Volvo.....	21
Watson & Chalin.....	22
White / Westport.....	22
Workhorse.....	22

## BUS STEERING KNUCKLE KING PIN KITS

Bluebird.....	23
Ford.....	23
Gillig.....	23
GMC Coach.....	23
International / Navistar.....	24
MAN.....	24
MCI.....	24
Neoplan.....	24
New Flyer.....	24
Rockwell / Meritor.....	24-25
Thomas.....	25
King Pin Dimensions Interchange.....	26

## KING PIN SUPPORT INFORMATION AND PRODUCTS

Manufacturers Spindle Bore and Axle Bore Dimensions.....	27
King Pin Service Tools.....	28

## FRONT SPRING PINS AND BUSHINGS

Advance Mixer.....	29
Bluebird.....	29
Crane Carrier.....	29
Ford.....	29
Freightliner.....	29
Gillig.....	29
HME.....	29
International / Navistar.....	30
Kenworth.....	30
KME.....	30
Mack.....	30
Oshkosh.....	30
Pierce.....	31
Peterbilt.....	31
Rosenbauer.....	31

Sterling.....	31
Sutphen Fire Chassis.....	31
Thomas.....	32
Volvo / GMC.....	32
Western Star.....	32
White.....	32
Spring Research Institute Identification.....	32

## REAR SPRING PINS AND BUSHINGS

Bluebird.....	33
Ford.....	33
Freightliner.....	33
Hendrickson.....	33
International / Navistar.....	33
Mack.....	33
Spring Service Tools.....	33

## INTERCHANGE SECTION

King Pin Interchange.....	34-46
Spring Pin Interchange.....	47-48
Bearing Interchange.....	48
Shim Pack Cross Reference.....	49
Tie Rod End Interchange to QWIKTIE™ Assembly.....	65-76

## COMPONENT PARTS SECTION

QwikKit®.....	50-55
PlusKit®.....	56-59
Econo Kit™.....	60-63

## WARRANTY:

STEMCO warrants the parts contained in STEMCO Kaiser Products to be free from defects in material and workmanship, under normal use and maintenance for a period of one year. This warranty shall be limited to replacing or allowing credit for the parts contained in the STEMCO Kaiser products providing that notice of defects and proof is promptly given. This warranty does not apply to damage or to defects in any parts contained in the STEMCO Kaiser products caused by misuse, neglect, accident, incorrect installation, alteration, or repair. THIS WARRANTY, AND THE MANUFACTURER'S OBLIGATION HEREUNDER IS IN LIEU OF ALL OTHER WARRANTIES, EXPRESS, IMPLIED OR STATUTORY, INCLUDING ANY WARRANTIES OF MERCHANTABILITY OR OF FITNESS FOR A PARTICULAR PURPOSE. THE FOREGOING EXPRESSES ALL OF STEMCO KAISER PRODUCTS' OBLIGATIONS AND LIABILITIES WITH RESPECT TO THE QUALITY OF ITEMS FURNISHED BY IT, AND IT SHALL UNDER NO CIRCUMSTANCES BE LIABLE FOR CONSEQUENTIAL, INDIRECT, OR SPECIAL LOSSES OR DAMAGES OR LOST PROFITS.

## WARRANTY CLAIMS:

The following procedure shall apply to all warranty claims:

- The end user must return all parts for which it intends to make a warranty claim to the authorized STEMCO Kaiser Distributor who sold it the parts in question, along with a properly filled out Warranty Claim Form.
- End users can obtain a Warranty Claim Form by contacting their authorized STEMCO Kaiser Distributor, who may obtain such form from STEMCO Kaiser's Warranty department.
- After obtaining a completed Warranty Claim Form from the end user, the STEMCO Kaiser Distributor must return to STEMCO Kaiser the following: (i) the parts in question, (ii) the completed Warranty Claim Form and (iii) a complete written history of the parts in question, including information concerning the vehicle from which the parts were removed.
- The STEMCO Kaiser Distributor must ship the parts and all documentation prepaid to STEMCO Kaiser, 4599 Industrial Drive, Millington, Michigan, 48746 for service analysis.
- Items deemed by STEMCO Kaiser to be defective under the terms of STEMCO Kaiser's warranty will be replaced. All claims will receive a service analysis report.

## DISCLAIMER NOTICE:

The use of a manufacturer's name, product number and part description in this catalog is intended to assist our customers in identifying replacement parts. Names referenced in this catalog may be trademarks or trade names of their respective manufacturers or suppliers and are not intended to show affiliation between STEMCO and the owners of those names. Every effort has been made to insure the accuracy of the information shown in this catalog. However, STEMCO assumes no liability for any errors or omissions in the information provided.

To order more catalogs, call and request Part #01-577-0002.

# STEERING KNUCKLE KING PIN KITS

MODEL	AXLE	YEAR	OEM NO.	PIN TYPE	OEM SPEC	QWIKKIT NO. <sup>1</sup>	PLUSKIT NO. <sup>2</sup>	ECONO KIT NO.	LIP SEAL/ BUSHING DRIVER INSTALLATION TOOL	AXLE SLEEVE USED WITH APE	APE CUTTER KIT USED
<b>ALLIANCE AXLE</b>											
	AF-6.0-2, AF-8.0-2		P6073300219KZ P6073300319KZ	B	1.771 x 8.06	<b>K80A</b>			ST70-30		
	AF-10.0-3, AF-12.0-3, AF-13.0-3, AF-13.3-3, AF-14.7-3		P6073300019KZ P6073300119KZ	B	1.771 x 9.23	<b>K120A</b>			ST70-30	92.120.01	84.122.05
	AF-16.0-5, AF-18.0-3, AF-20.3-3		P6073300419KZ P6073300519KZ	B	2.125 x 9.75	<b>K160A</b>			ST70-31		
<b>CHEVROLET</b>											
¾ & 1 Ton P20, P30		1960-1964	3854744	A	1.109 x 6.34	<b>K51G</b>			ST70-14		
		1964-1967	3858389 3927942	A	1.109 x 6.34	<b>K51G</b>			ST70-14		
	5000#	1986 to date	15522020 15584763	A	1.179 x 6.35	<b>K56G</b>	70.056.07	50.056.07	ST70-4	91.056.07	84.056.07
C30HD - Heavy Duty Pickup			15665666 88911968 88911987	A	1.179 x 6.35	<b>K56G</b>	70.056.07	50.056.07	ST70-4	91.056.07	84.056.07
1 ½ Ton - C40, P40	5000# (F-050)	1964-1975	3858389 3927942	A	1.109 x 6.34	<b>K51G</b>			ST70-14		
	5000# (F-050)	1975-1990	722166	A	1.179 x 6.35	<b>K55G</b>	70.055.07	50.055.07	ST70-4	91.056.07	84.056.07
	7000# (F-070)	1963-1984	3927943 8885857	A	1.249 x 7.87	<b>K70G</b>	70.070.07	50.070.07	ST70-1		
1 ½ Ton & 2 Ton - C50, D50, L50, M50, N50, P50, S50, T50, C5D, O50	5000# (F-050)	1963-1975	3829410 3927942	A	1.109 x 6.34	<b>K51G</b>			ST70-14		
	5000# (F-050)	1975-1990	722166	A	1.179 x 6.35	<b>K55G</b>	70.055.07	50.055.07	ST70-4	91.056.07	84.056.07
	7000# (F-070)	1965-1975	3838390 3927943	A	1.249 x 7.87	<b>K70G</b>	70.070.07	50.070.07	ST70-1		
	9000# (F-090)	1963-1972	2321013 2431372 8885021	E	1.434 x 8.75	<b>K95G<sup>12</sup></b>	70.095.07 <sup>12</sup>	50.095.07 <sup>12</sup>	ST70-9		
	11000# (F-110)	1965-1970	2264897	E	1.609 x 9.75	<b>K125G<sup>12</sup></b>	70.125.07 <sup>12</sup>	50.125.07 <sup>12</sup>	ST70-5		
	12000# (F-120)	1966-1973	2264897	E	1.609 x 9.75	<b>K125G<sup>12</sup></b>	70.125.07 <sup>12</sup>	50.125.07 <sup>12</sup>	ST70-5		
2 Ton - A60, B60, C60, D60, L60, M60, N60, P60, Q60, S60, T60, V60, X60, Y60	5000#	1963-1975	3858389 3927942	A	1.109 x 6.34	<b>K51G</b>			ST70-14		
	5000#	1975-1990	722166	A	1.179 x 6.35	<b>K55G</b>	70.055.07	50.055.07	ST70-4	91.056.07	84.056.07
	7000# (F-070) Some 6000#	1963-	3838390 3927943	A	1.249 x 7.87	<b>K70G</b>	70.070.07	50.070.07	ST70-1		
	9000# (F-090) Some 8100#	1965-	2321013 2431372 8885021	E	1.434 x 8.75	<b>K95G<sup>12</sup></b>	70.095.07 <sup>12</sup>	50.095.07 <sup>12</sup>	ST70-9		
	11000# (F-110)	1965-1975	2264897	E	1.609 x 9.75	<b>K125G<sup>12</sup></b>	70.125.07 <sup>12</sup>	50.125.07 <sup>12</sup>	ST70-5		
	12000# (F-120)	1966-1975	2264897	E	1.609 x 9.75	<b>K125G<sup>12</sup></b>	70.125.07 <sup>12</sup>	50.125.07 <sup>12</sup>	ST70-5		
	12000# (F-120D)	1975-1990	8885621	B	1.745 x 9.37	<b>K121G<sup>7</sup></b>	70.121.07 <sup>7</sup>	50.121.07 <sup>7</sup>	ST70-11		
	Top Kick - C-Series	6000# (FN9)		88936084	A	1.234 x 6.78	<b>K60R</b>			ST70-3	91.060.18

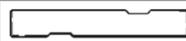
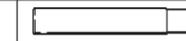
PIN TYPE CHART:			
	<b>A</b> - SINGLE LOCK FLAT		<b>E</b> - TAPERED THREADED
	<b>B</b> - DOUBLE LOCK FLAT		<b>F</b> - TAPERED
	<b>G</b> - STEP THREADED		<b>H</b> - NO LOCK FLATS
	<b>J</b> - SINGLE STEP		

1. STEMCO Kaiser QwikKit® feature patented spiral steel bushings. 2. STEMCO Kaiser PlusKit® feature pre-sized steel back bronze bushings. 3. Kit has composite bushings. 4. Modify spindles to receive end plates. 5. Bolt on cap. 6. Threaded cap. 7. Length of STEMCO Kaiser pin is 9 3/4". 8. STEMCO Kaiser pin is longer than OEM. 9. Torque Spec. for king pin nut 230 ft/lbs. 10. Torque Spec. for king pin nut is 300 ft/lbs. 11. Torque Spec. for king pin nut is 406 ft/lbs. 12. Torque Spec. for king pin nut is 350/475 ft/lbs. 13. Includes end caps. 14. Torque Spec. for knuckle attachment bolts is 170-200 ft/lbs. 15. Kit uses special removal tool ST90-1.

MODEL	AXLE	YEAR	OEM NO.	PIN TYPE	OEM SPEC	QWIKKIT NO. <sup>1</sup>	PLUSKIT NO. <sup>2</sup>	ECONO KIT NO.	LIP SEAL/ BUSHING DRIVER INSTALLATION TOOL	AXLE SLEEVE USED WITH APE	APE CUTTER KIT USED	
<b>CHEVROLET CONT.</b>												
Top Kick - C - Series	7000# (FM7)		88936119	B	1.499 x 7.15	<b>K70R</b>	70.070.18	50.070.18	ST70-28			
	8000# (FM8)		88936011	B	1.499 x 7.50	<b>K80R</b>	70.080.18	50.080.18	ST70-28			
	10000# (FM6)			B	1.794 x 10.40	<b>K120R</b>	70.120.18	50.120.18	ST70-7			
	8100# (FL1)	1990 to date	12540328 15619560	G	1.614 x 8.00	<b>K80G<sup>11</sup></b>						
Top Kick - T - Series	9000# 11000# (FL2) 12000# (FS7)	1990 to date	12540329 15619561	G	1.889 x 9.20	<b>K110G<sup>11</sup></b>						
	14000# (FH0) 14500# (FL3) 14600# (FSD)	1990 to date	12540330 15619562	G	1.889 x 9.62	<b>K120G<sup>11</sup></b>						
2 ½ Ton - C70, C7D, H70, J70, R70, S70, ST7, T70, W70	7000# (F-070)	1963 to date	3838390 3927943	A	1.249 x 7.87	<b>K70G</b>	70.070.07	50.070.07	ST70-1			
	9000# (F-090)	1962 to date	2321013 2431372 8885021	E	1.434 x 8.75	<b>K95G<sup>12</sup></b>	70.095.07 <sup>12</sup>	50.095.07 <sup>12</sup>	ST70-9			
	11000# (F-110)	1962-1975	2264897	E	1.609 x 9.75	<b>K125G<sup>12</sup></b>	70.125.07 <sup>12</sup>	50.125.07 <sup>12</sup>	ST70-5			
	12000# (F-120)	1966-1975	2264897	E	1.609 x 9.75	<b>K125G<sup>12</sup></b>	70.125.07 <sup>12</sup>	50.125.07 <sup>12</sup>	ST70-5			
	12000# (F-120D)	1975 to date	8885621	B	1.745 x 9.37	<b>K121G<sup>7</sup></b>	70.121.07 <sup>7</sup>	50.121.07 <sup>7</sup>	ST70-11			
	FF-932 13200#		15510849	B	1.794 x 10.39	<b>K931L</b>	70.931.12	50.931.12	ST70-7	92.961.12	84.122.05	
	FG-943 14600#			B	1.794 x 10.39	<b>K6931R</b>	77.931.18	57.931.18	ST70-7	92.931.18	84.122.05	
	18000# (FL-901)	1971 to date	2452865	B	1.999 x 10.90	<b>KH901L</b>	78.901.12	58.901.12	ST70-12			
	2 ½ & 3 Ton - A80, C80, E80, H80, J80, L80, M80, N80, Q80	7000# (F-070)	1963 to date	3838390 3927943	A	1.249 x 7.87	<b>K70G</b>	70.070.07	50.070.07	ST70-1		
		9000# (F-090)	1962 to date	2321013 2431372 8885021	E	1.434 x 8.75	<b>K95G<sup>12</sup></b>	70.095.07 <sup>12</sup>	50.095.07 <sup>12</sup>	ST70-9		
11000# (F-110)		1962-1975	2264897	E	1.609 x 9.75	<b>K125G<sup>12</sup></b>	70.125.07 <sup>12</sup>	50.125.07 <sup>12</sup>	ST70-5			
12000# (F-120)		1966-1975	2264897	E	1.609 x 9.75	<b>K125G<sup>12</sup></b>	70.125.07 <sup>12</sup>	50.125.07 <sup>12</sup>	ST70-5			
12000# (F-120D)		1975 to date	8885621	B	1.745 x 9.37	<b>K121G<sup>7</sup></b>	70.121.07 <sup>7</sup>	50.121.07 <sup>7</sup>	ST70-11			
18000# (FL-901)		1971 to date	2452865	B	1.999 x 10.90	<b>KH901L</b>	78.901.12	58.901.12	ST70-12			
3 ½ Ton - D90, F90, H90, J90, M90, T90, W90	9000# (F-090)	1970 to date	2321013 2431372 8885021	E	1.434 x 8.75	<b>K95G<sup>12</sup></b>	70.095.07 <sup>12</sup>	50.095.07 <sup>12</sup>	ST70-9			
	12000# (F-120)	1970-1975	2264897	E	1.609 x 9.75	<b>K125G<sup>12</sup></b>	70.125.07 <sup>12</sup>	50.125.07 <sup>12</sup>	ST70-5			
	12000# (FE-900)	1970-1975	2264897	E	1.609 x 9.75	<b>K125G<sup>12</sup></b>	70.125.07 <sup>12</sup>	50.125.07 <sup>12</sup>	ST70-5			
	12000# (F-120D)	1975 to date	8885621	B	1.745 x 9.37	<b>K121G</b>	70.121.07	50.121.07	ST70-11			
	18000# (FL-901)	1970 to date	2452865	B	1.999 x 10.90	<b>KH901L</b>	78.901.12	58.901.12	ST70-12			
	16000# (FL-931)	1973-1978	2036352	B	1.999 x 11.21	<b>KH931L</b>	78.931.12	58.931.12	ST70-12	92.931.12	84.931.12	
<b>CLARK (INDUSTRIAL AXLES)</b>												
F-553 Air Start/ Gen. Carts				A	1.234 x 7.62	<b>K98I</b>	70.098.09	50.098.09	ST70-10			

## FOR ALL QWIKKIT® - BUSHING "T" HANDLE WRENCHES

TOOL NO.	DESCRIPTION
ST-100-1	Short "T" Handle Wrench
ST-100-2	Long "T" Handle Wrench
100M1-1	Replacement head

Above Wrenches will fit the bushings in most kits. The Following kits do not use wrenches:  
K80A, K120A, K120N, K150XG, K160A, K700T, K60U, 50.121.08

TOOL NO.	DESCRIPTION
ST-100-3	Short "T" Handle Wrench
ST-100-4	Long "T" Handle Wrench
100M1-2	Replacement head

Above Wrenches will fit the bushings in the following kits:  
K50F, K71F, K72F, K80G, K110G, K120G, K122V, K146E, K147E, K180E, K68Z, K69Z

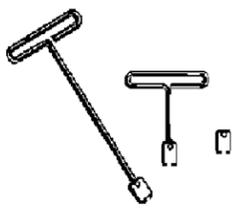

# STEERING KNUCKLE KING PIN KITS

MODEL	AXLE	YEAR	OEM NO.	PIN TYPE	OEM SPEC	QWIKKIT NO. <sup>1</sup>	PLUSKIT NO. <sup>2</sup>	ECONO KIT NO.	LIP SEAL/ BUSHING DRIVER INSTALLATION TOOL	AXLE SLEEVE USED WITH APE	APE CUTTER KIT USED
<b>DODGE</b>											
2 Ton - C500, D500, M500, R500, S500, PC500, PD500	7000#	1957-1973	1843208	B	1.234 x 7.43	<b>K70D</b>	70.070.04	50.070.04	ST70-10		
2 1/2 Ton - C600, D600, L600, S600, PC600, PD600, C700, CT700, D700, L700, S700	7000#	1957-1973	1843208	B	1.234 x 7.43	<b>K70D</b>	70.070.04	50.070.04	ST70-10		
	7000#	1960-1973	1843208	B	1.234 x 7.43	<b>K70D</b>	70.070.04	50.070.04	ST70-10		
	9000#	1960-1973	1818726	B	1.433 x 8.50	<b>KD901R</b>	74.901.18	54.901.18	ST70-9		
	11000#	1960-1968	1643174	E	1.609 x 9.75	<b>K125G<sup>12</sup></b>	70.125.07 <sup>12</sup>	50.125.07 <sup>12</sup>	ST70-5		
	12000#	1969-1971	2808618	B	1.794 x 9.12	<b>K901L</b>	70.901.12	50.901.12	ST70-7		
	7000#	1960-1973	1843208	B	1.234 x 7.43	<b>K70D</b>	70.070.04	50.070.04	ST70-10		
	9000#	1960 to date	1818726	B	1.433 x 8.50	<b>KD901R</b>	74.901.18	54.901.18	ST70-9		
3 Ton - C800, CN800, CNT800, D800, NCT800, C850	11000#	1960-1968	1643174	E	1.609 x 9.75	<b>K125G<sup>12</sup></b>	70.125.07 <sup>12</sup>	50.125.07 <sup>12</sup>	ST70-5		
	12000#	1969-1977	2808618	B	1.794 x 9.12	<b>K901L</b>	70.901.12	50.901.12	ST70-7		
	7000#	1960-1973	1843208	B	1.234 x 7.43	<b>K70D</b>	70.070.04	50.070.04	ST70-10		
	9000#	1960 to date	1818726	B	1.433 x 8.50	<b>KD901R</b>	74.901.18	54.901.18	ST70-9		
4 Ton - C900, CN900, CT900, CNT900, NC900, NCT900, VL900, VLT900	11000#	1960-1968	1643174	E	1.609 x 9.75	<b>K125G<sup>12</sup></b>	70.125.07 <sup>12</sup>	50.125.07 <sup>12</sup>	ST70-5		
	12000#	1969-1973	2808618	B	1.794 x 9.12	<b>K901L</b>	70.901.12	50.901.12	ST70-7		
	16000#	1974 to date		B	1.999 x 11.04	<b>KH901L</b>	78.901.12	58.901.12	ST70-12		
	7000#	1960-1973	1843208	B	1.234 x 7.43	<b>K70D</b>	70.070.04	50.070.04	ST70-10		
5 Ton - C1000, CT1000, DNT1000, LNT1000, LNT1000	9000#	1960 to date	1818726	B	1.433 x 8.50	<b>KD901R</b>	74.901.18	54.901.18	ST70-9		
	11000#	1960-1968	1643174	E	1.609 x 9.75	<b>K125G<sup>12</sup></b>	70.125.07 <sup>12</sup>	50.125.07 <sup>12</sup>	ST70-5		
	12000#	1969-1973	2808618	B	1.794 x 9.12	<b>K901L</b>	70.901.12	50.901.12	ST70-7		
	16000#	1974 to date		B	1.999 x 11.04	<b>KH901L</b>	78.901.12	58.901.12	ST70-12		
<b>EAGLE</b>											
05	12000#		123	E	1.609 x 9.75	<b>K125G<sup>12</sup></b>	70.125.07 <sup>12</sup>	50.125.07 <sup>12</sup>	ST70-5		
<b>EATON (SEE SPICER / DANA / EATON)</b>											
<b>FORD</b>											
E100, E250, E350		1975 to date	D5UZ-3111B D5UZ-3111D E0TZ-3111A	A	1.054 x 6.68	<b>KE350F</b>	75.350.06	55.350.06	ST70-15		
1/2 Ton (Twin-I-Beam)	2600# Manual Brakes	1975 to date	D5TZ-3111B	A	1.054 x 6.68	<b>KE350F</b>	75.350.06	55.350.06	ST70-15		
3/4 Ton (Twin-I-Beam) F250 Conventional 2 wheel drive		1980-1986	E0TZ-3111A	A	1.054 x 6.68	<b>KE350F</b>	75.350.06	55.350.06	ST70-15		
1 Ton (Twin-I-Beam) F350 Conventional 2 wheel drive		1980-1986	E0TZ-3111A	A	1.054 x 6.68	<b>KE350F</b>	75.350.06	55.350.06	ST70-15		
F450 Super Duty		1988-1998	E8TZ-3111A	A	1.300 x 7.26	<b>K71F</b>	70.071.06	50.071.06	ST70-17		
1 1/2 Ton B500, F500, LN500, N500, C500, P500	4700# - 5000#	1963 to date	C3TZ-3111A D2TZ-3111D	A	1.231 x 7.54	<b>K50F<sup>4</sup></b>	70.053.06	50.053.06	ST70-3		

PIN TYPE CHART:			
	<b>A</b> – SINGLE LOCK FLAT		<b>E</b> – TAPERED THREADED
	<b>B</b> – DOUBLE LOCK FLAT		<b>F</b> – TAPERED
	<b>C</b> – SAME SIDE LOCK FLATS		<b>G</b> – STEP THREADED
	<b>D</b> – TAPERED THREADED		<b>H</b> – NO LOCK FLATS
	<b>J</b> – SINGLE STEP		

1. STEMCO Kaiser QwikKit® feature patented spiral steel bushings. 2. STEMCO Kaiser PlusKit® feature pre-sized steel back bronze bushings. 3. Kit has composite bushings. 4. Modify spindles to receive end plates. 5. Bolt on cap. 6. Threaded cap. 7. Length of STEMCO Kaiser pin is 9 3/4". 8. STEMCO Kaiser pin is longer than OEM. 9. Torque Spec. for king pin nut is 230 ft/lbs. 10. Torque Spec. for king pin nut is 300 ft/lbs. 11. Torque Spec. for king pin nut is 406 ft/lbs. 12. Torque Spec. for king pin nut is 350/475 ft/lbs. 13. Includes end caps. 14. Torque Spec. for knuckle attachment bolts is 170-200 ft/lbs. 15. Kit uses special removal tool ST90-1.

MODEL	AXLE	YEAR	OEM NO.	PIN TYPE	OEM SPEC	QWIKKIT NO. <sup>1</sup>	PLUSKIT NO. <sup>2</sup>	ECONO KIT NO.	LIP SEAL/ BUSHING DRIVER INSTALLATION TOOL	AXLE SLEEVE USED WITH APE	APE CUTTER KIT USED
<b>FORD CONT.</b>											
1 1/2 Ton C500, P500 C550, P600	4700# - 5000#	1978-1979	C3TZ-3111A	A	1.231 x 7.54	<b>K50F<sup>4</sup></b>	70.053.06	50.053.06	ST70-3		
	6000#	1970-1973	C7TZ-3111A	A	1.230 x 8.90	<b>K70F<sup>4</sup></b>	70.073.06	50.073.06	ST70-3		
	7000#	1961-1969	B7TZ-3111B C2TZ-3111B	B	1.234 x 7.43	<b>K70D</b>	70.070.04	50.070.04	ST70-10		
	7000#	1970-1988	C7TZ-3111A	A	1.230 x 8.90	<b>K70F<sup>4</sup></b>	70.073.06	50.073.06	ST70-3		
2 Ton - B600, C600, F600, LN600, N600	5000# - 5500#	1963 to date	C3TZ-3111A D2TZ-3111D	A	1.231 x 7.85	<b>K50F<sup>4</sup></b>	70.053.06	50.053.06	ST70-3		
	6000#	1967-1988	C7TZ-3111A	A	1.230 x 8.90	<b>K70F<sup>4</sup></b>	70.073.06	50.073.06	ST70-3		
	6000# - 7000#	1967-1974	C7TZ-3111A	A	1.230 x 8.90	<b>K70F<sup>4</sup></b>	70.073.06	50.073.06	ST70-3		
	7000#	1961-1966	B7TZ-3111B C2TZ-3111B	B	1.234 x 7.43	<b>K70D</b>	70.070.04	50.070.04	ST70-10		
	7000# Hydraulic Brakes	1967-1988	C7TZ-3111A	A	1.230 x 8.90	<b>K70F<sup>4</sup></b>	70.073.06	50.073.06	ST70-3		
	7000-9000# Air Brakes	1975-1988	D6TZ-3111A	B	1.430 x 8.25	<b>K75F<sup>5</sup></b>	70.075.06 <sup>5</sup>	50.075.06 <sup>5</sup>	ST70-9		
	7000-9000# Air Brakes	1989-2003	E9HZ-3111C	B	1.430 x 8.25	<b>K76F<sup>6</sup></b>	70.076.06 <sup>6</sup>	50.076.06 <sup>6</sup>	ST70-9		
	14600#	1995-1998	F5HZ-3111A	B	1.810 x 10.54	<b>K146F</b>			ST70-33		
2 1/2 Ton - B700, C700, F700, LN700, N700, T700, B750, C750, F750, LN750, N750, T750	5000-5500#	1963 to date	C3TZ-3111A D2TZ-3111D	A	1.231 x 7.85	<b>K50F<sup>4</sup></b>	70.053.06	50.053.06	ST70-3		
	6000#	1967-1988	C7TZ-3111A	A	1.230 x 8.90	<b>K70F<sup>4</sup></b>	70.073.06	50.073.06	ST70-3		
	6000# - 7000#	1990 to date	E8HZ-3111A F1HZ-3111A	B	1.300 x 7.75	<b>K72F</b>	70.072.06	50.072.06	ST70-17		
	7000#	1957-1966	C7TZ-3111A	A	1.230 x 8.90	<b>K70F<sup>4</sup></b>	70.073.06	50.073.06	ST70-3		
	7000#		C2TZ-3111B	B	1.234 x 7.43	<b>K70D</b>	70.070.04	50.070.04	ST70-10		
	7000# Hydraulic Brakes	1967-1988	C7TZ-3111A	A	1.230 x 8.90	<b>K70F<sup>4</sup></b>	70.073.06	50.073.06	ST70-3		
	7000# Air Brakes	1989-2003	E9HZ-3111C	B	1.430 x 8.25	<b>K76F<sup>6</sup></b>	70.076.06 <sup>6</sup>	50.076.06 <sup>6</sup>	ST70-9		
	7000-9000# Air Brakes After Series No. 40001	1975-1988	D6TZ-3111A	B	1.430 x 8.25	<b>K75F<sup>5</sup></b>	70.075.06 <sup>5</sup>	50.075.06 <sup>5</sup>	ST70-9		
	9000# Hydraulic Brakes	1960-1983	D1HZ-3111A C2TZ-3111G	B	1.433 x 8.50	<b>KD901R</b>	74.901.18	54.901.18	ST70-9		
	9000# Air Brakes	1975-1988	D6HZ-3111B D6HZ-3111D	B	1.606 x 9.07	<b>K95F<sup>5</sup></b>	70.095.06 <sup>5</sup>	50.095.06 <sup>5</sup>	ST70-13		
	9000# Air Brakes	1989 to date	E9HZ-3111B	B	1.606 x 9.07	<b>K96F<sup>6</sup></b>	70.096.06 <sup>6</sup>	50.096.06 <sup>6</sup>	ST70-13		
	C.P.S. 11000#	1960-1973	D0HZ-3111C	B	1.606 x 8.81	<b>K970R</b>	70.970.18	50.970.18	ST70-13		
C.P.S. 12000#	1960-1973	D0HZ-3111C	B	1.606 x 8.81	<b>K970R</b>	70.970.18	50.970.18	ST70-13			
12000# Conventional	1960-1969	C3TZ-3111B D1HZ-3111B	B	1.794 x 9.12	<b>K901L</b>	70.901.12	50.901.12	ST70-7			
14600#	1995-1998	F5HZ-3111A	B	1.810 x 10.54	<b>K146F</b>			ST70-33			
800-850-880 Series	6000#	1970-1988	C7TZ-3111A	A	1.230 x 8.90	<b>K70F<sup>4</sup></b>	70.073.06	50.073.06	ST70-3		
	7000#	1957-1969	B7TZ-3111B C2TZ-3111B	B	1.234 x 7.43	<b>K70D</b>	70.070.04	50.070.04	ST70-10		
	7000# Hydraulic Brakes	1970-1988	C7TZ-3111A	A	1.230 x 8.90	<b>K70F<sup>4</sup></b>	70.073.06	50.073.06	ST70-3		

## FOR ALL QWIKKIT® – BUSHING "T" HANDLE WRENCHES

TOOL NO.	DESCRIPTION
ST-100-1	Short "T" Handle Wrench
ST-100-2	Long "T" Handle Wrench
100M1-1	Replacement head
Above Wrenches will fit the bushings in most kits. The Following kits do not use wrenches: K80A, K120A, K120N, K150XG, K160A, K700T, K60U, 50.121.08	

TOOL NO.	DESCRIPTION
ST-100-3	Short "T" Handle Wrench
ST-100-4	Long "T" Handle Wrench
100M1-2	Replacement head
Above Wrenches will fit the bushings in the following kits: K50F, K71F, K72F, K80G, K110G, K120G, K122V, K146E, K147E, K180E, K68Z, K69Z	

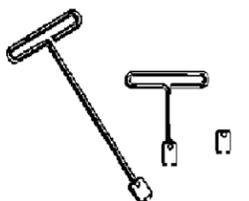

# STEERING KNUCKLE KING PIN KITS

MODEL	AXLE	YEAR	OEM NO.	PIN TYPE	OEM SPEC	QWIKKIT NO. <sup>1</sup>	PLUSKIT NO. <sup>2</sup>	ECONO KIT NO.	LIP SEAL/ BUSHING DRIVER INSTALLATION TOOL	AXLE SLEEVE USED WITH APE	APE CUTTER KIT USED
<b>FORD CONT.</b>											
800-850-880 Series	7000-9000# Air Brakes After Series No. 40, 001	1975-1988	D6TZ-3111A	B	1.430 x 8.25	<b>K75F<sup>5</sup></b>	70.075.06 <sup>5</sup>	50.075.06 <sup>5</sup>	ST70-9		
	7000# Air Brakes	1989 to date	E9HZ-3111C	B	1.430 x 8.25	<b>K76F<sup>5</sup></b>	70.076.06 <sup>5</sup>	50.076.06 <sup>5</sup>	ST70-9		
	9000# Hydraulic Brakes	1957-1983	D1HZ-3111A C2TZ-3111G	B	1.433 x 8.50	<b>KD901R</b>	74.901.18	54.901.18	ST70-9		
	9000# Air Brakes	1975-1988	D6HZ-3111B D6HZ-3111D	B	1.606 x 9.07	<b>K95F<sup>5</sup></b>	70.095.06 <sup>5</sup>	50.095.06 <sup>5</sup>	ST70-13		
	9000# Air Brakes	1989 to date	E9HZ-3111B	B	1.606 x 9.07	<b>K96F<sup>5</sup></b>	70.096.06 <sup>5</sup>	50.096.06 <sup>5</sup>	ST70-13		
	11000# Conventional	1957-1963	B7TZ-3111C	E	1.609 x 9.75	<b>K125G<sup>12</sup></b>	70.125.07 <sup>12</sup>	50.125.07 <sup>12</sup>	ST70-5		
	C.P.S. 11000#	1964-1970	D0HZ-3111C	B	1.606 x 8.81	<b>K970R</b>	70.970.18	50.970.18	ST70-13		
	12000# Conventional	1960-1988	C3TZ-3111B D1HZ-3111B	B	1.794 x 9.12	<b>K901L</b>	70.901.12	50.901.12	ST70-7		
	C.P.S. 12000# Hydraulic Brakes	1960-1970	D0HZ-3111C	B	1.606 x 8.81	<b>K970R</b>	70.970.18	50.970.18	ST70-13		
	12000# Conventional	1975-1988	D6HZ-3111A	B	1.794 x 10.07	<b>K941F<sup>5</sup></b>	70.941.06 <sup>5</sup>	50.941.06 <sup>5</sup>	ST70-7	92.942.06	84.122.05
	12000# Conventional	1989 to date	E9HZ-3111A F0HZ-3111A	B	1.794 x 10.07	<b>K942F<sup>5</sup></b>	70.942.06 <sup>5</sup>	50.942.06 <sup>5</sup>	ST70-7	92.942.06	84.122.05
	12000# ALUMINUM	1978-1988	D8HZ-3111A	B	1.794 x 10.07	<b>K941FA<sup>5</sup></b>			ST70-7		
	12000# ALUMINUM	1989-	F6HZ-3111BB	B	1.794 x 10.07	<b>K942FA<sup>5</sup></b>			ST70-7		
	14600#	1995-1998	F5HZ-3111A	B	1.810 x 10.54	<b>K146F</b>			ST70-33		
	16000# Air Brakes	1970-1974	D0HZ-3111E	B	1.999 x 11.04	<b>KH901L</b>	78.901.12	58.901.12	ST70-12		
	16000# Air Brakes	1975 to date	D5HZ-3111C	B	1.999 x 11.21	<b>KH931F</b>	78.931.06	58.931.06	ST70-12	92.931.12	84.931.12
	18000# Hydraulic Brakes	1960-1974	D0HZ-3111E	B	1.999 x 11.04	<b>KH901L</b>	78.901.12	58.901.12	ST70-12		
	18000# Air Brakes	1975 to date	D5HZ-3111C	B	1.999 x 11.21	<b>KH931F</b>	78.931.06	58.931.06	ST70-12	92.931.12	84.931.12
	20000#	1970-1974	D0HZ-3111E	B	1.999 x 11.04	<b>KH901L</b>	78.901.12	58.901.12	ST70-12		
	20000#	1975 to date	D5HZ-3111C	B	1.999 x 11.21	<b>KH931F</b>	78.931.06	58.931.06	ST70-12	92.931.12	84.931.12
900-950 Series	7000#	1960-1969	B7TZ-3111B C2TZ-3111B	B	1.234 x 7.43	<b>K70D</b>	70.070.04	50.070.04	ST70-4		
	7000# Hydraulic Brakes	1970-1988	C7TZ-3111A	A	1.230 x 8.90	<b>K70F<sup>4</sup></b>	70.073.06	50.073.06	ST70-3		
	7000# 9000-10000# After Series No. 40, 001	1975-1988	D6TZ-3111A	B	1.430 x 8.25	<b>K75F<sup>5</sup></b>	70.075.06 <sup>5</sup>	50.075.06 <sup>5</sup>	ST70-9		
	7000# Air Brakes	1989 to date	E9HZ-3111C	B	1.430 x 8.25	<b>K76F<sup>5</sup></b>	70.076.06 <sup>5</sup>	50.076.06 <sup>5</sup>	ST70-9		
	9000# Hydraulic Brakes	1957-1983	D1HZ-3111A C2TZ-3111G	B	1.433 x 8.50	<b>KD901R</b>	74.901.18	54.901.18	ST70-9		
	9000# Air Brakes	1975-1988	D6HZ-3111B D6HZ-3111D	B	1.606 x 9.07	<b>K95F<sup>5</sup></b>	70.095.06 <sup>5</sup>	50.095.06 <sup>5</sup>	ST70-13		
	9000# Air Brakes	1989 to date	E9HZ-3111B	B	1.606 x 9.07	<b>K96F<sup>5</sup></b>	70.096.06 <sup>5</sup>	50.096.06 <sup>5</sup>	ST70-13		

MODEL	AXLE	YEAR	OEM NO.	PIN TYPE	OEM SPEC	QWIKKIT NO. <sup>1</sup>	PLUSKIT NO. <sup>2</sup>	ECONO KIT NO.	LIP SEAL/ BUSHING DRIVER INSTALLATION TOOL	AXLE SLEEVE USED WITH APE	APE CUTTER KIT USED
<b>FORD CONT.</b>											
900-950 Series	11000# Conventional	1957-1963	B7TZ-3111C	E	1.609 x 9.75	<b>K125G<sup>12</sup></b>	70.125.07 <sup>12</sup>	50.125.07 <sup>12</sup>	ST70-5		
	C.P.S. 11000#	1964-1970	D0HZ-3111C	B	1.606 x 8.81	<b>K970R</b>	70.970.18	50.970.18	ST70-13		
	12000# Conventional Hydraulic Brakes	1960-1988	C3TZ-3111B D1HZ-3111B	B	1.794 x 9.12	<b>K901L</b>	70.901.12	50.901.12	ST70-7		
	C.P.S. 12000#	1960-1973	D0HZ-3111C	B	1.606 x 8.81	<b>K970R</b>	70.970.18	50.970.18	ST70-13		
	12000# Conventional	1975-1988	D6HZ-3111A	B	1.794 x 10.07	<b>K941F<sup>5</sup></b>	70.941.06 <sup>5</sup>	50.941.06 <sup>5</sup>	ST70-7	92.942.06	84.122.05
	12000# Conventional	1989 to date	E9HZ-3111A F0HZ-3111A	B	1.794 x 10.07	<b>K942F<sup>5</sup></b>	70.942.06 <sup>5</sup>	50.942.06 <sup>5</sup>	ST70-7	92.942.06	84.122.05
	12000# ALUMINUM	1978-1988	D8HZ-3111A	B	1.794 x 10.07	<b>K941FA<sup>5</sup></b>			ST70-7		
	12000# ALUMINUM	1989-	F6HZ-3111BB	B	1.794 x 10.07	<b>K942FA<sup>5</sup></b>			ST70-7		
	14600#	1995-1998	F5HZ-3111A	B	1.810 x 10.54	<b>K146F</b>			ST70-33		
	16000# Air Brakes	1970-1974	D0HZ-3111E	B	1.999 x 11.04	<b>KH901L</b>	78.901.12	58.901.12	ST70-12		
	16000# Air Brakes	1975 to date	D5HZ-3111C	B	1.999 x 11.21	<b>KH931F</b>	78.931.06	58.931.06	ST70-12	92.931.12	84.931.12
	18000# Hydraulic Brakes	1960-1974	D0HZ-3111E	B	1.999 x 11.04	<b>KH901L</b>	78.901.12	58.901.12	ST70-12		
	18000# Air Brakes	1975 to date	D5HZ-3111C	B	1.999 x 11.21	<b>KH931F</b>	78.931.06	58.931.06	ST70-12	92.931.12	84.931.12
	20000#	1970-1974	D0HZ-3111E	B	1.999 x 11.04	<b>KH901L</b>	78.901.12	58.901.12	ST70-12		
	20000#	1975 to date	D5HZ-3111C	B	1.999 x 11.21	<b>KH931F</b>	78.931.06	58.931.06	ST70-12	92.931.12	84.931.12
<b>FREIGHTLINER (SEE ROCKWELL / MERITOR, SPICER / DANA / EATON)</b>											
<b>FWD (SEE ROCKWELL / MERITOR, SPICER / DANA / EATON)</b>											
<b>GMC</b>											
P1500		1960-1965	3927942	A	1.109 x 6.34	<b>K51G</b>			ST70-14		
G1500		1966-1967	3854744	A	1.109 x 6.34	<b>K51G</b>			ST70-14		
P2500		1960-1965	3927942	A	1.109 x 6.34	<b>K51G</b>			ST70-14		
		1966-1967	3854744	A	1.109 x 6.34	<b>K51G</b>			ST70-14		
C3500 - Heavy Duty Pickup		1991-	15665666	A	1.179 x 6.35	<b>K56G</b>	70.056.07	50.056.07	ST70-4	91.056.07	84.056.07
3500 Series - Conventional	5000# (F-050)	1963-1966	3927942	A	1.109 x 6.34	<b>K51G</b>			ST70-14		
P3500	5000# (F-050)	1965-1967	3854744	A	1.109 x 6.34	<b>K51G</b>			ST70-14		
	5000#	1986 to date	15522020 88911968 88911987	A	1.179 x 6.35	<b>K56G</b>	70.056.07	50.056.07	ST70-4	91.056.07	84.056.07
4000 Series	5000# (F-050, F-055)	1963-1966	3927942	A	1.109 x 6.34	<b>K51G</b>			ST70-14		
	7000# (F-070)	1963-1966	3838390 3927943	A	1.249 x 7.87	<b>K70G</b>	70.070.07	50.070.07	ST70-1		
4500 Series	5000# (F-055)	1967-1970	3927942	A	1.109 x 6.34	<b>K51G</b>			ST70-14		

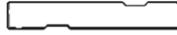
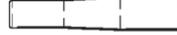
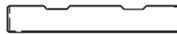
PIN TYPE CHART:			
	<b>A</b> – SINGLE LOCK FLAT		<b>E</b> – TAPERED THREADED
	<b>B</b> – DOUBLE LOCK FLAT		<b>F</b> – TAPERED
	<b>C</b> – SAME SIDE LOCK FLATS		<b>G</b> – STEP THREADED
	<b>H</b> – NO LOCK FLATS		<b>J</b> – SINGLE STEP

1. STEMCO Kaiser QwikKit® feature patented spiral steel bushings. 2. STEMCO Kaiser PlusKit® feature pre-sized steel back bronze bushings. 3. Kit has composite bushings. 4. Modify spindles to receive end plates. 5. Bolt on cap. 6. Threaded cap. 7. Length of STEMCO Kaiser pin is 9 3/4". 8. STEMCO Kaiser pin is longer than OEM. 9. Torque Spec. for king pin nut is 230 ft/lbs. 10. Torque Spec. for king pin nut is 300 ft/lbs. 11. Torque Spec. for king pin nut is 406 ft/lbs. 12. Torque Spec. for king pin nut is 350/475 ft/lbs. 13. Includes end caps. 14. Torque Spec. for knuckle attachment bolts is 170-200 ft/lbs. 15. Kit uses special removal tool ST90-1.

## FOR ALL QWIKKIT® – BUSHING "T" HANDLE WRENCHES

TOOL NO.	DESCRIPTION
ST-100-1	Short "T" Handle Wrench
ST-100-2	Long "T" Handle Wrench
100M1-1	Replacement head
Above Wrenches will fit the bushings in most kits. The Following kits do not use wrenches: K80A, K120A, K120N, K150XG, K160A, K700T, K60U, 50.121.08	

TOOL NO.	DESCRIPTION
ST-100-3	Short "T" Handle Wrench
ST-100-4	Long "T" Handle Wrench
100M1-2	Replacement head
Above Wrenches will fit the bushings in the following kits: K50F, K71F, K72F, K80G, K110G, K120G, K122V, K146E, K147E, K180E, K68Z, K69Z	

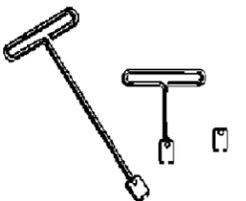

# STEERING KNUCKLE KING PIN KITS

MODEL	AXLE	YEAR	OEM NO.	PIN TYPE	OEM SPEC	QWIKKIT NO. <sup>1</sup>	PLUSKIT NO. <sup>2</sup>	ECONO KIT NO.	LIP SEAL/ BUSHING DRIVER INSTALLATION TOOL	AXLE SLEEVE USED WITH APE	APE CUTTER KIT USED	
<b>GMC CONT.</b>												
5000 Series - B5000, DW5000, W5000	5000# (F-050)	1967-1972	3854744	A	1.109 x 6.34	<b>K51G</b>			ST70-14			
All other 5000 Series	5000# (F-050, F-055)	1967-1970	3927942	A	1.109 x 6.34	<b>K51G</b>			ST70-14			
	7000# (F-070)	1963-1966	3838390 3927943	A	1.249 x 7.87	<b>K70G</b>	70.070.07	50.070.07	ST70-1			
All other 5500 Series	5000# (F-050)	1966-1970	3927942	A	1.109 x 6.34	<b>K51G</b>			ST70-14			
	5000# (F-050)	1966-1972	3854744	A	1.109 x 6.34	<b>K51G</b>			ST70-14			
	5000# (F-055)	1975-1990	722166	A	1.179 x 6.35	<b>K55G</b>	70.055.07	50.055.07	ST70-4	91.056.07	84.056.07	
	7000# (F-070)	1963 to date	3838390 3927943	A	1.249 x 7.87	<b>K70G</b>	70.070.07	50.070.07	ST70-1			
	9000# (F-090)	1970 to date	2321013 8885021	E	1.434 x 8.75	<b>K95G<sup>12</sup></b>	70.095.07 <sup>12</sup>	50.095.07 <sup>12</sup>	ST70-9			
KODIAK - C Series	7000# (FM7)		88936119	B	1.499 x 7.15	<b>K70R</b>	70.070.18	50.070.18	ST70-28			
	8000# (FM8)		88936011	B	1.499 x 7.50	<b>K80R</b>	70.080.18	50.080.18	ST70-28			
	10000# (FM6)			B	1.794 x 10.40	<b>K120R</b>	70.120.18	50.120.18	ST70-7			
	8100# (FL1)		12540328 1561960	G	1.614 x 8.00	<b>K80G<sup>11</sup></b>						
	9000# (F12) 11000# (F12) 12000# (FS7)		12540329 1561961	G	1.889 x 9.20	<b>K110G<sup>11</sup></b>						
	14000# (FH0) 14500# (FL3) 14600# (FSD)	1990 to date	12540330 1561962	G	1.889 x 9.62	<b>K120G<sup>11</sup></b>						
	16000# (FH4)		88936136	B	1.999 x 11.21	<b>K181R</b>	70.181.18	50.181.18	ST70-12	92.931.12	84.931.12	
	EFA18F3 16000#		12541348	A	1.872 x 9.96	<b>K180E</b>	70.180.05	50.180.05	ST70-23	91.180.08	84.147.05	
	6000 Series	5000# (F-050, F-055)	1973-1975	3927942	A	1.109 x 6.34	<b>K51G</b>			ST70-14		
		5000# (F-050, F-055)	1975-1990	722166	A	1.179 x 6.36	<b>K55G</b>	70.055.07	50.055.07	ST70-4	91.056.07	84.056.07
7000# (F-070)		1973 to date	3838390 3927943	A	1.249 x 7.87	<b>K70G</b>	70.070.07	50.070.07	ST70-1			
9000# (F-090)		1960 to date	2321013 8885021	E	1.434 x 8.75	<b>K95G<sup>12</sup></b>	70.095.07 <sup>12</sup>	50.095.07 <sup>12</sup>	ST70-9			
11000# (F-110) 12000# (F-120)		1960 to date	2264897	E	1.609 x 9.75	<b>K125G<sup>12</sup></b>	70.125.07 <sup>12</sup>	50.125.07 <sup>12</sup>	ST70-5			
6500 Series	7000# (F-070)	1963 to date	3838390 3927943	A	1.249 x 7.87	<b>K70G</b>	70.070.07	50.070.07	ST70-1			
	9000# (F-090)	1960 to date	2321013 8885021	E	1.434 x 8.75	<b>K95G<sup>12</sup></b>	70.095.07 <sup>12</sup>	50.095.07 <sup>12</sup>	ST70-9			
	11000# (F-110)	1960-1975	2264897	E	1.609 x 9.75	<b>K125G<sup>12</sup></b>	70.125.07 <sup>12</sup>	50.125.07 <sup>12</sup>	ST70-5			
	12000# (F-120)	1963-1975	2264897	E	1.609 x 9.75	<b>K125G<sup>12</sup></b>	70.125.07 <sup>12</sup>	50.125.07 <sup>12</sup>	ST70-5			
	12000# (F-120D)	1975 to date	8885621	B	1.745 x 9.37	<b>K121G<sup>7</sup></b>	70.121.07 <sup>7</sup>	50.121.07 <sup>7</sup>	ST70-11			
7000 Series	9000# (F-090)	1960-1966	2321013 8885021	E	1.434 x 8.75	<b>K95G<sup>12</sup></b>	70.095.07 <sup>12</sup>	50.095.07 <sup>12</sup>	ST70-9			
	11000# (F-110)	1960-1966	2264897	E	1.609 x 9.75	<b>K125G<sup>12</sup></b>	70.125.07 <sup>12</sup>	50.125.07 <sup>12</sup>	ST70-5			
7500 Series	7000# (F-070)	1966 to date	3838390 3927943	A	1.249 x 7.87	<b>K70G</b>	70.070.07	50.070.07	ST70-1			

MODEL	AXLE	YEAR	OEM NO.	PIN TYPE	OEM SPEC	QWIKKIT NO. <sup>1</sup>	PLUSKIT NO. <sup>2</sup>	ECONO KIT NO.	LIP SEAL/ BUSHING DRIVER INSTALLATION TOOL	AXLE SLEEVE USED WITH APE	APE CUTTER KIT USED	
<b>GMC CONT.</b>												
7500 Series	9000# (F-090)	1966 to date	2321013 8885021	E	1.434 x 8.75	<b>K95G<sup>12</sup></b>	70.095.07 <sup>12</sup>	50.095.07 <sup>12</sup>	ST70-9			
	11000# (F-110)	1963-1975	2264897	E	1.609 x 9.75	<b>K125G<sup>12</sup></b>	70.125.07 <sup>12</sup>	50.125.07 <sup>12</sup>	ST70-5			
	12000# (F-120)	1963-1975	2264897	E	1.609 x 9.75	<b>K125G<sup>12</sup></b>	70.125.07 <sup>12</sup>	50.125.07 <sup>12</sup>	ST70-5			
	12000# (F-120D)	1975 to date	8885621	B	1.745 x 9.37	<b>K121G<sup>7</sup></b>	70.121.07 <sup>7</sup>	50.121.07 <sup>7</sup>	ST70-11			
	18000# (FL-901)	1970 to date	2452865	B	1.999 x 11.04	<b>KH901L</b>	78.901.12	58.901.12	ST70-12			
8500 Series	7000# (F-070)	1966 to date	3838390 3927943	A	1.249 x 7.87	<b>K70G</b>	70.070.07	50.070.07	ST70-1			
	9000# (F-090)	1963 to date	2321013 8885021	E	1.434 x 8.75	<b>K95G<sup>12</sup></b>	70.095.07 <sup>12</sup>	50.095.07 <sup>12</sup>	ST70-9			
	11000# (F-110)	1963-1972	2264897	E	1.609 x 9.75	<b>K125G<sup>12</sup></b>	70.125.07 <sup>12</sup>	50.125.07 <sup>12</sup>	ST70-5			
	12000# (F-120)	1963-1975	2264897	E	1.609 x 9.75	<b>K125G<sup>12</sup></b>	70.125.07 <sup>12</sup>	50.125.07 <sup>12</sup>	ST70-5			
	12000# (F-120D)	1975 to date	8885621	B	1.745 x 9.38	<b>K121G<sup>7</sup></b>	70.121.07 <sup>7</sup>	50.121.07 <sup>7</sup>	ST70-11			
	18000# (FL-901)	1971 to date	2452865	B	1.999 x 11.04	<b>KH901L</b>	78.901.12	58.901.12	ST70-12			
9000 Series	11000# (F-110)	1960-1962	2264897	E	1.609 x 9.75	<b>K125G<sup>12</sup></b>	70.125.07 <sup>12</sup>	50.125.07 <sup>12</sup>	ST70-5			
9500 Series	7000# (F-070)	1966 to date	3838390 3927943	A	1.249 x 7.87	<b>K70G</b>	70.070.07	50.070.07	ST70-1			
	9000# (F-090)	1966 to date	2321013 8885021	E	1.434 x 8.75	<b>K95G<sup>12</sup></b>	70.095.07 <sup>12</sup>	50.095.07 <sup>12</sup>	ST70-9			
	11000# (F-110)	1963-1975	2264897	E	1.609 x 9.75	<b>K125G<sup>12</sup></b>	70.125.07 <sup>12</sup>	50.125.07 <sup>12</sup>	ST70-5			
	11000# (FE-970)	1966-1972	2442145	B	1.606 x 8.81	<b>K970R</b>	70.970.18	50.970.18	ST70-13			
	12000# (F-120)	1963-1975	2264897	E	1.609 x 9.75	<b>K125G<sup>12</sup></b>	70.125.07 <sup>12</sup>	50.125.07 <sup>12</sup>	ST70-5			
	12000# (FE-900)	1966-1972	2264897	E	1.609 x 9.75	<b>K125G<sup>12</sup></b>	70.125.07 <sup>12</sup>	50.125.07 <sup>12</sup>	ST70-5			
	12000# (F-120D)	1975 to date	8885621	B	1.745 x 9.37	<b>K121G<sup>7</sup></b>	70.121.07 <sup>7</sup>	50.121.07 <sup>7</sup>	ST70-11			
	18000# (FL-901)	1966 to date	2452865	B	1.999 x 11.04	<b>KH901L</b>	78.901.12	58.901.12	ST70-12			
		18000# (FL-931)		2036352	B	1.999 x 11.21	<b>KH931L</b>	78.931.12	58.931.12	ST70-12	92.931.12	84.931.12
	<b>HENDRICKSON</b>											
FRONT STEER AXLE	AIRTEK SOFTEK STEERTEK 64905-004		60961-009 60961-039 60961-040 00063311 LT SIDE 00063312 RT SIDE 00063313 BT SIDES					50.121.08	ST70-32			
REAR TAG AXLES	UST		002916	A	1.810 x 10.56	<b>K126W</b>	70.126.23	50.126.23	ST70-33	91.127.23	84.122.05	
	UC2, UC3, UC4 US2, US3, US4		003270 003200	H	1.810 x 9.54	<b>K120H<sup>14</sup></b>			ST70-33			
	USP		001434	A	1.810 x 10.56	<b>K127W</b>	70.127.23	50.127.23	ST70-33	91.127.23	84.122.05	
			006648	A	1.810 x 9.54	<b>K131H</b>			ST70-33			
<b>HINO</b>												
NA, NB, NC		2005-2008	R201478	A	1.234 x 6.78	<b>K60R</b>			ST70-3	91.060.18	84.060.18	
ND, NE, NJ-258 A-LP	8,000#	2005-2008	R201474	B	1.499 x 7.50	<b>K80R</b>	70.080.18	50.080.18	ST70-28			
ND, NE, NJ, NV	10,000#	2005-2008	R201470	B	1.794 x 10.40	<b>K961L</b>	70.961.12	50.961.12	ST70-7	92.961.12	84.122.05	
<b>IMT / INGERSOLL</b>												
	700214		700040	B	2.248 x 11.30	<b>K700T</b>	70.700.20		ST70-29	92.700.20	84.700.20	

PIN TYPE CHART:			
	<b>A</b> - SINGLE LOCK FLAT		<b>E</b> - TAPERED THREADED
	<b>B</b> - DOUBLE LOCK FLAT		<b>G</b> - STEP THREADED
			<b>F</b> - TAPERED
			<b>H</b> - NO LOCK FLATS
			<b>J</b> - SINGLE STEP

1. STEMCO Kaiser QwikKit® feature patented spiral steel bushings. 2. STEMCO Kaiser PlusKit® feature pre-sized steel back bronze bushings. 3. Kit has composite bushings. 4. Modify spindles to receive end plates. 5. Bolt on cap. 6. Threaded cap. 7. Length of STEMCO Kaiser pin is 9 3/4". 8. STEMCO Kaiser pin is longer than OEM. 9. Torque Spec. for king pin nut 230 ft/lbs. 10. Torque Spec. for king pin nut is 300 ft/lbs. 11. Torque Spec. for king pin nut is 406 ft/lbs. 12. Torque Spec. for king pin nut is 350/475 ft/lbs. 13. Includes end caps. 14. Torque Spec. for knuckle attachment bolts is 170-200 ft/lbs. 15. Kit uses special removal tool ST90-1.

## FOR ALL QWIKKIT® - BUSHING "T" HANDLE WRENCHES

TOOL NO.	DESCRIPTION
ST-100-1	Short "T" Handle Wrench
ST-100-2	Long "T" Handle Wrench
100M1-1	Replacement head

Above Wrenches will fit the bushings in most kits. The Following kits do not use wrenches: K80A, K120A, K120N, K150XG, K160A, K700T, K60U, 50.121.08

TOOL NO.	DESCRIPTION
ST-100-3	Short "T" Handle Wrench
ST-100-4	Long "T" Handle Wrench
100M1-2	Replacement head

Above Wrenches will fit the bushings in the following kits: K50F, K71F, K72F, K80G, K110G, K120G, K122V, K146E, K147E, K180E, K68Z, K69Z

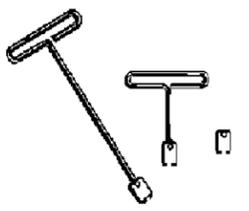

# STEERING KNUCKLE KING PIN KITS

MODEL	AXLE	YEAR	OEM NO.	PIN TYPE	OEM SPEC	QWIKKIT NO. <sup>1</sup>	PLUSKIT NO. <sup>2</sup>	ECONO KIT NO.	LIP SEAL/ BUSHING DRIVER INSTALLATION TOOL	AXLE SLEEVE USED WITH APE	APE CUTTER KIT USED
<b>INTERNATIONAL / NAVISTAR</b>											
7500# FA-65		1957-1966	61556R91	A	1.234 x 7.65	<b>K981</b>	70.098.09	50.098.09	ST70-10		
8200# FA-71		1975-1988	473695C91	A	1.359 x 7.96	<b>K1011</b>	70.101.09	50.101.09	ST70-2	91.101.09	84.103.19
8200# FA-73		1975-1988	473695C91	A	1.359 x 7.96	<b>K1011</b>	70.101.09	50.101.09	ST70-2	91.101.09	84.103.19
8200# FA-74		1975-1988	473695C91	A	1.359 x 7.96	<b>K1011</b>	70.101.09	50.101.09	ST70-2	91.101.09	84.103.19
7500# FA-80		1950-1968	61556R91	A	1.234 x 7.65	<b>K981</b>	70.098.09	50.098.09	ST70-10		
7500# FA-91		1960-1968	61556R91	A	1.234 x 7.65	<b>K981</b>	70.098.09	50.098.09	ST70-10		
7500# FA-98		1950-1975	61556R91	A	1.234 x 7.65	<b>K981</b>	70.098.09	50.098.09	ST70-10		
7500# FA-99		1957-1975	61556R91	A	1.234 x 7.65	<b>K981</b>	70.098.09	50.098.09	ST70-10		
9000# FA-100		1950-1968	303136C92	B	1.433 x 8.50	<b>KD901R</b>	74.901.18	54.901.18	ST70-9		
7500# FA-101		1962-1975	61556R91	A	1.234 x 7.65	<b>K981</b>	70.098.09	50.098.09	ST70-10		
8200# FA-101 FA-104		1975-1988	473695C91 1648204C91	A	1.359 x 7.96	<b>K1011</b>	70.101.09	50.101.09	ST70-2	91.101.09	84.103.19
8200# FA-101 FA-104		1989 to date	1660271C92	B	1.359 x 7.96	<b>K1021</b>	70.102.09	50.102.09	ST70-2	92.102.09	84.103.19
9000# FA-102		1963-1968	303136C92	B	1.433 x 8.50	<b>KD901R</b>	74.901.18	54.901.18	ST70-9		
7500# FA-103			473695C91	A	1.359 x 7.96	<b>K1011</b>	70.101.09	50.101.09	ST70-2	91.101.09	84.103.19
9000# FA-105		1955-1975	303136C92	B	1.433 x 8.50	<b>KD901R</b>	74.901.18	54.901.18	ST70-9		
9000# FA-109		1970-1981	408547C91 408547C93 472093C91	B	1.484 x 8.85	<b>K1091</b>		50.109.09			
9000# FA-109		1981 to date	493092C91 493095C92	A	1.484 x 8.85	<b>K1081</b>		50.108.09			
12000# FA-110		1950-1968	155932R92 303137C92 69576R92	E	1.609 x 9.75	<b>K125G<sup>12</sup></b>	70.125.07 <sup>12</sup>	50.125.07 <sup>12</sup>	ST70-5		
12000# FA-112		1960-1975	229265R91 303138C92	B	1.606 x 8.81	<b>K970R</b>	70.970.18	50.970.18	ST70-13		
12000# FA-113		1960-1975	229265R91 303138C92	B	1.606 x 8.81	<b>K970R</b>	70.970.18	50.970.18	ST70-13		
12000# FA-115		1955-1968	155932R92 303137C92 69576R92	E	1.609 x 9.75	<b>K125G<sup>12</sup></b>	70.125.07 <sup>12</sup>	50.125.07 <sup>12</sup>	ST70-5		
12000# FA-118		1981 to date	399942C93 588808C91 1658934C91	B	1.609 x 9.65	<b>K1401</b>	70.140.09	50.140.09	ST70-5	92.140.09	84.120.05
12000# FA-127		1981 to date	588808C91 1658934C91 399942C93	B	1.609 x 9.65	<b>K1401</b>	70.140.09	50.140.09	ST70-5	92.140.09	84.120.05
18000# FA-136		1963-1975	303140C92	B	1.999 x 11.04	<b>KH901L</b>	78.901.12	58.901.12	ST70-12		
12000# FA-139		1975-1981	472094C91 491611C93 493094C93	A	1.609 x 9.65	<b>K1391</b>	70.139.09	50.139.09	ST70-5		
12000# FA-139		1981 to date	588808C91 1658934C91 399942C93	B	1.609 x 9.65	<b>K1401</b>	70.140.09	50.140.09	ST70-5	92.140.09	84.120.05
12000# FA-201		1960-1972	303139C92 870148R92	B	1.794 x 9.12	<b>K901L</b>	70.901.12	50.901.12	ST70-7		

MODEL	AXLE	YEAR	OEM NO.	PIN TYPE	OEM SPEC	QWIKKIT NO. <sup>1</sup>	PLUSKIT NO. <sup>2</sup>	ECONO KIT NO.	LIP SEAL/ BUSHING DRIVER INSTALLATION TOOL	AXLE SLEEVE USED WITH APE	APE CUTTER KIT USED
<b>INTERNATIONAL / NAVISTAR CONT</b>											
9000# FA-208		1960-1975	303136C92	B	1.433 x 8.50	<b>KD901R</b>	74.901.18	54.901.18	ST70-9		
9000# FA-209		1960-1975	303136C92	B	1.433 x 8.50	<b>KD901R</b>	74.901.18	54.901.18	ST70-9		
12000# FA-211		1960-1973	303139C92 870148R92	B	1.794 x 9.12	<b>K901L</b>	70.901.12	50.901.12	ST70-7		
12000# FA-212		1960-1973	303139C92 870148R92	B	1.794 x 9.12	<b>K901L</b>	70.901.12	50.901.12	ST70-7		
12000# FA-215 FA-216, FA-217		1960-1973	303139C92 870148R92	B	1.794 x 9.12	<b>K901L</b>	70.901.12	50.901.12	ST70-7		
12000# FA-218		1960-1973	303139C92 870148R92	B	1.794 x 9.12	<b>K901L</b>	70.901.12	50.901.12	ST70-7		
12000# FA-219		1963-1973	303139C92 870148R92	B	1.794 x 9.12	<b>K901L</b>	70.901.12	50.901.12	ST70-7		
12000# FA-228		1973 to date	452344C91	B	1.794 x 10.39	<b>K921L</b>	70.921.12	50.921.12	ST70-7		
16000# FA-231			474520C91	B	1.999 x 11.21	<b>KH931L</b>	78.931.12	58.931.12	ST70-12	92.931.12	84.931.12
18000# FA-232			474520C91	B	1.999 x 11.21	<b>KH931L</b>	78.931.12	58.931.12	ST70-12	92.931.12	84.931.12
9000# FA-309		1975-1981	470752C91 493095C91	A	1.609 x 9.15	<b>K3091</b>	70.309.09	50.309.09	ST70-5		
9000# FA-309		1981 to date	586806C91	B	1.609 x 9.15	<b>K3101</b>	70.310.09	50.310.09	ST70-5		
10800# FA-329		1975-1981	472094C91 491611C92 493094C92 493094C93	A	1.609 x 9.65	<b>K1391</b>	70.139.09	50.139.09	ST70-5		
12000# FA-329		1981 to date	588808C91 1658934C91 399942C93 1655421C91	B	1.609 x 9.65	<b>K1401</b>	70.140.09	50.140.09	ST70-5	92.140.09	84.120.05
12000# FA-339		1975-1981	472094C91 491611C92 493094C92 493094C93	A	1.609 x 9.65	<b>K1391</b>	70.139.09	50.139.09	ST70-5		
12000# FA-339 FA-337 FA-343		1981 to date	588808C91 1658934C91 399942C93	B	1.609 x 9.65	<b>K1401</b>	70.140.09	50.140.09	ST70-5	92.140.09	84.120.05
10800# FA-341 Aluminum Axle			472094C91 491611C92 493094C92 493094C93	A	1.609 x 9.65	<b>K1391</b>	70.139.09	50.139.09	ST70-5		
12000# FA-342 FA-343		1981 to date	588808C91 1658934C91 399942C93 493094C93	B	1.609 x 9.65	<b>K1401</b>	70.140.09	50.140.09	ST70-5	92.140.09	84.120.05
5000# I-050			473695C91	A	1.359 x 7.96	<b>K1011</b>	70.101.09	50.101.09	ST70-2	91.101.09	84.103.19
6000# I-060			473695C91	A	1.359 x 7.96	<b>K1011</b>	70.101.09	50.101.09	ST70-2	91.101.09	84.103.19
7500# I-075			473695C91	A	1.359 x 7.96	<b>K1011</b>	70.101.09	50.101.09	ST70-2	91.101.09	84.103.19
8000# I-80S, I-80SG, O2-ADB, O2-ADV			1660271C92	B	1.359 x 7.96	<b>K1021</b>	70.102.09	50.102.09	ST70-2	92.102.09	84.103.19
8000# O2-AEM, O2-AHA			3573204C91	C	1.359 x 7.97	<b>K103S</b>	70.103.19	50.103.19	ST70-2	93.103.19	84.103.19
9000# I-090		Before Aug. 1981	470752C91 493095C91	A	1.609 x 9.15	<b>K3091</b>	70.309.09	50.309.09	ST70-5		

PIN TYPE CHART:			
	<b>A</b> – SINGLE LOCK FLAT		<b>E</b> – TAPERED THREADED
	<b>B</b> – DOUBLE LOCK FLAT		<b>F</b> – TAPERED
	<b>C</b> – SAME SIDE LOCK FLATS		<b>G</b> – STEP THREADED
	<b>H</b> – NO LOCK FLATS		<b>J</b> – SINGLE STEP

1. STEMCO Kaiser QwikKit® feature patented spiral steel bushings. 2. STEMCO Kaiser PlusKit® feature pre-sized steel back bronze bushings. 3. Kit has composite bushings. 4. Modify spindles to receive end plates. 5. Bolt on cap. 6. Threaded cap. 7. Length of STEMCO Kaiser pin is 9 3/4". 8. STEMCO Kaiser pin is longer than OEM. 9. Torque Spec. for king pin nut 230 ft/lbs. 10. Torque Spec. for king pin nut is 300 ft/lbs. 11. Torque Spec. for king pin nut is 406 ft/lbs. 12. Torque Spec. for king pin nut is 350/475 ft/lbs. 13. Includes end caps. 14. Torque Spec. for knuckle attachment bolts is 170-200 ft/lbs. 15. Kit uses special removal tool ST90-1.

## FOR ALL QWIKKIT® – BUSHING "T" HANDLE WRENCHES

TOOL NO.	DESCRIPTION
ST-100-1	Short "T" Handle Wrench
ST-100-2	Long "T" Handle Wrench
100M1-1	Replacement head
Above Wrenches will fit the bushings in most kits. The Following kits do not use wrenches: K80A, K120A, K120N, K150XG, K160A, K700T, K60U, 50.121.08	

TOOL NO.	DESCRIPTION
ST-100-3	Short "T" Handle Wrench
ST-100-4	Long "T" Handle Wrench
100M1-2	Replacement head
Above Wrenches will fit the bushings in the following kits: K50F, K71F, K72F, K80G, K110G, K120G, K122V, K146E, K147E, K180E, K68Z, K69Z	

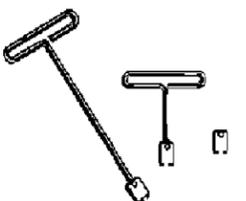

# STEERING KNUCKLE KING PIN KITS

MODEL	AXLE	YEAR	OEM NO.	PIN TYPE	OEM SPEC	QWIKKIT NO. <sup>1</sup>	PLUSKIT NO. <sup>2</sup>	ECONO KIT NO.	LIP SEAL/ BUSHING DRIVER INSTALLATION TOOL	AXLE SLEEVE USED WITH APE	APE CUTTER KIT USED
<b>INTERNATIONAL / NAVISTAR CONT.</b>											
	9000# I-090	After Aug. 1981	586806C91	B	1.609 x 9.15	<b>K310I</b>	70.310.09	50.310.09	ST70-5		
	10000# I-100S I-100SG, 02-ADC		1688411C92	B	1.921 x 9.87	<b>K120I<sup>8</sup></b>	70.120.09 <sup>8</sup> 70.120.99 <sup>3,8</sup>	50.120.09 <sup>8</sup>	ST70-19	92.120.09	84.147.05
	10000# I-100W 02-AER		329022	B	2.046 x 10.12	<b>K141S<sup>9</sup></b>	70.141.19 <sup>8</sup>	50.141.19 <sup>8</sup>	ST70-24		
	10800# I-108 All except code 02309		588808C91 399942C93	B	1.609 x 9.65	<b>K140I</b>	70.140.09	50.140.09	ST70-5	92.140.09	84.120.05
	10800# I-108 For code 02309		586806C91	B	1.609 x 9.15	<b>K310I</b>	70.310.09	50.310.09	ST70-5		
	12000# I-120 All except code 02309		588808C91 399942C93	B	1.609 x 9.65	<b>K140I</b>	70.140.09	50.140.09	ST70-5	92.140.09	84.120.05
	12000# I-120 For code 02309		586806C91	B	1.609 x 9.15	<b>K310I</b>	70.310.09	50.310.09	ST70-5		
	12000# I-120S I-120SG, 02-ADD 02-ADG, 02-ADP	1989 to date	1668411C91 1659688C91 1659686C91 1659687C91	B	1.921 x 9.87	<b>K120I<sup>8</sup></b>	70.120.09 <sup>8</sup> 70.120.99 <sup>3,8</sup>	50.120.09 <sup>8</sup>	ST70-19	92.120.09	84.147.05
	13200# I-132 I-132S		586806C91	B	1.609 x 9.65	<b>K140I</b>	70.140.09	50.140.09	ST70-5	92.140.09	84.120.05
	14000# I-140S 02-ADE	1990 to date	1668412C91	B	2.046 x 10.12	<b>K141S<sup>9</sup></b>	70.141.19 <sup>8</sup>	50.141.19 <sup>8</sup>	ST70-24		
<b>With Rockwell Axles:</b>											
	12000# FE-900	1950-1962	303137C92 69576R92 155932R92	E	1.609 x 9.75	<b>K125G<sup>12</sup></b>	70.125.07 <sup>12</sup>	50.125.07 <sup>12</sup>	ST70-5		
	12000# FE-970	1964-1968	229265R91 303138C92	B	1.606 x 8.81	<b>K970R</b>	70.970.18	50.970.18	ST70-13		
	12000# FF-921	1972 to date	452344C91	B	1.794 x 10.39	<b>K921L</b>	70.921.12	50.921.12	ST70-7		
	18000# FL-901		303140C92 870148R92	B	1.999 x 11.04	<b>KH901L</b>	78.901.12	58.901.12	ST70-12		
	12000# FE-971		577684C91	B	1.607 x 9.37	<b>K971R</b>			ST70-13		
	12000# FF-931 FF-941		549800C91	B	1.794 x 10.40	<b>K931L</b>	70.931.12	50.931.12	ST70-7	92.961.12	84.122.05
	12000# FF-961 02-ARV, 02-ARA 02-ARW		2505492C91	B	1.794 x 10.40	<b>K961L</b>	70.961.12	50.961.12	ST70-7	92.961.12	84.122.05
	12000# 02-AED 02-AEG			A	1.794 x 9.05	<b>K122E</b>	70.122.05	50.122.05	ST70-7	91.122.05	84.122.05
	18000# FL-931 FL-941		474520C91	B	1.999 x 11.21	<b>KH931L</b>	78.931.12	58.931.12	ST70-12	92.931.12	84.931.12
	18000# 02-ARU		2505495C91	B	1.999 x 11.21	<b>K180R</b>	70.180.18	50.180.18	ST70-12	92.180.18	84.931.12
	12000# FF-981 02-ARK, 02-ARL 02-ASB, 02-ASD		2500542C91	B	1.794 x 8.87	<b>K981R</b>	70.981.18	50.981.18	ST70-7	92.961.12	84.122.05
<b>ISUZU</b>											
FTR			12540329	G	1.889 x 9.20	<b>K110G</b>					
NPR		1990-1998	5-87830978-2 94058104	A	1.181 x 7.38	<b>K68Z</b>	70.068.26		ST70-37	91.068.26	84.056.07

MODEL	AXLE	YEAR	OEM NO.	PIN TYPE	OEM SPEC	QWIKKIT NO. <sup>1</sup>	PLUSKIT NO. <sup>2</sup>	ECONO KIT NO.	LIP SEAL/ BUSHING DRIVER INSTALLATION TOOL	AXLE SLEEVE USED WITH APE	APE CUTTER KIT USED
<b>ISUZU CONT.</b>											
NPR		1998-present	5-87831608-1 97723802 98441181 5-87832211-1	A	1.181 x 7.38	<b>K69Z</b>	70.069.26		ST70-37	91.068.26	84.056.07
<b>KENWORTH (SEE ROCKWELL / MERITOR, SPICER / DANA / EATON)</b>											
<b>KGI</b>											
	15000# KGS150		579-1044	A	1.999 x 11.32	<b>K150KG</b>			ST70-26	91.150.07	84.931.12
	23000# KGS230		KAS31	A	2.249 x 10.60	<b>K230KG</b>	70.230.07		ST70-29	94.230.07	84.700.20
<b>KIMBLE MIXER</b>											
			T41-12001-71	C	1.872 x 9.05	<b>K149E</b>			ST70-23	93.147.05	84.147.05
<b>LINK</b>											
	12000# DuraLift & Model 9000		84001930	A	1.794 x 9.05	<b>K123K</b>			ST70-7		
	13200# DuraLift & Model 9000		84001931	A	1.794 x 9.05	<b>K132K</b>			ST70-7	91.132.11	84.122.05
<b>MACK</b>											
Midliner MS-CS	7500# 9500#		50.00336305	A	1.377 x 7.00	<b>K75M</b>					
DM, RM, DUMP, MIXER, CONSTRUCTION, REFUSE	10000# FA-507 FA-5071		301SQ46A	F	1.500 x 7.40	<b>K535M<sup>4</sup></b>					
	10000# FA-512		301SQ46A	F	1.500 x 7.40	<b>K535M<sup>4</sup></b>					
	10000# FA-514 FA-5141		301SQ46A	F	1.500 x 7.40	<b>K535M<sup>4</sup></b>					
	10000# FA-517		301SQ46A	F	1.500 x 7.40	<b>K535M<sup>4</sup></b>					
	12000# FA-522 FA-5221	1963 to date	301SQ47CPI 301SQ47D	F	1.625 x 7.46	<b>K533M thin wall bushing</b>	70.533.13	50.533.13	ST70-6		
	12000# FA-523 FA-5231	1963 to date	301SQ47CPI 301SQ47D 301SQ47E	F	1.625 x 7.46	<b>K533M thin wall bushing</b>	70.533.13	50.533.13	ST70-6		
	12000# FA-532 FA-538	1950 to date	301SQ47CPI 301SQ47D 301SQ47E	F	1.625 x 7.46	<b>K533M thin wall bushing</b>	70.533.13	50.533.13	ST70-6		
	10000# FA-535		301SQ46A	F	1.500 x 7.40	<b>K535M<sup>4</sup></b>					
	12000# FXL12		301SQ53	E	2.360 x 8.92	<b>K536M<sup>15</sup></b>					
	14600# FXL14.6		301SQ53	E	2.360 x 8.92	<b>K536M<sup>15</sup></b>					
	18000# FA-602 FA-604		205S012	B	1.999 x 10.90	<b>KH901L</b>	78.901.12	58.901.12	ST70-12		
	18000# FA-616 FA-617		301SQ52	F	2.125 x 8.75	<b>K616M</b>	70.616.13	50.616.13	ST70-18		
18000# FXL18		301SQ53	E	2.360 x 8.92	<b>K536M<sup>15</sup></b>						
20000# FA-616 FA-617		301SQ52	F	2.125 x 8.75	<b>K616M</b>	70.616.13	50.616.13	ST70-18			

PIN TYPE CHART:			
	<b>A</b> – SINGLE LOCK FLAT		<b>E</b> – TAPERED THREADED
	<b>B</b> – DOUBLE LOCK FLAT		<b>F</b> – TAPERED
	<b>C</b> – SAME SIDE LOCK FLATS		<b>G</b> – STEP THREADED
	<b>H</b> – NO LOCK FLATS		<b>J</b> – SINGLE STEP

1. STEMCO Kaiser QwikKit® feature patented spiral steel bushings. 2. STEMCO Kaiser PlusKit® feature pre-sized steel back bronze bushings. 3. Kit has composite bushings. 4. Modify spindles to receive end plates. 5. Bolt on cap. 6. Threaded cap. 7. Length of STEMCO Kaiser pin is 9 3/4". 8. STEMCO Kaiser pin is longer than OEM. 9. Torque Spec. for king pin nut 230 ft/lbs. 10. Torque Spec. for king pin nut is 300 ft/lbs. 11. Torque Spec. for king pin nut is 406 ft/lbs. 12. Torque Spec. for king pin nut is 350/475 ft/lbs. 13. Includes end caps. 14. Torque Spec. for knuckle attachment bolts is 170-200 ft/lbs. 15. Kit uses special removal tool ST90-1.

## FOR ALL QWIKKIT® – BUSHING "T" HANDLE WRENCHES

TOOL NO.	DESCRIPTION
ST-100-1	Short "T" Handle Wrench
ST-100-2	Long "T" Handle Wrench
100M1-1	Replacement head
Above Wrenches will fit the bushings in most kits. The Following kits do not use wrenches: K80A, K120A, K120N, K150KG, K160A, K700T, K60U, 50.121.08	

TOOL NO.	DESCRIPTION
ST-100-3	Short "T" Handle Wrench
ST-100-4	Long "T" Handle Wrench
100M1-2	Replacement head
Above Wrenches will fit the bushings in the following kits: K50F, K71F, K72F, K80G, K110G, K120G, K122V, K146E, K147E, K180E, K68Z, K69Z	

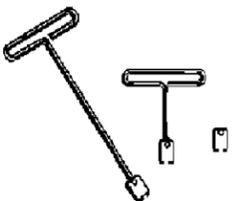

# STEERING KNUCKLE KING PIN KITS

MODEL	AXLE	YEAR	OEM NO.	PIN TYPE	OEM SPEC	QWIKKIT NO. <sup>1</sup>	PLUSKIT NO. <sup>2</sup>	ECONO KIT NO.	LIP SEAL/ BUSHING DRIVER INSTALLATION TOOL	AXLE SLEEVE USED WITH APE	APE CUTTER KIT USED
<b>MACK CONT.</b>											
DM, RM, DUMP, MIXER, CONSTRUCTION, REFUSE	20000# FXL20		301S053	E	2.360 x 8.92	<b>K536M<sup>15</sup></b>					
	23000# FXL23		301S053	E	2.360 x 8.92	<b>K536M<sup>15</sup></b>					
	24000# FA-616 FA-617		301S052	F	2.125 x 8.75	<b>K616M</b>	70.616.13	50.616.13	ST70-18		
With Rockwell Axles:	12000# FE-900	1960-1966	205S011	E	1.609 x 9.75	<b>K125G<sup>12</sup></b>	70.125.07 <sup>12</sup>	50.125.07 <sup>12</sup>	ST70-5		
	12000# FF-921	1972 to date	205S015	B	1.794 x 10.39	<b>K921L</b>	70.921.12	50.921.12	ST70-7		
	18000# FL-901		205S012	B	1.999 x 11.04	<b>KH901L</b>	78.901.12	58.901.12	ST70-12		
<b>MAN</b>											
	V8 65C-02	1993	81.44205-6013 6313078	J	1.969 x 8.77	<b>K120N</b>			ST70-27		
<b>MCI</b>											
MC-7, MC-8, MC-9	12000#		121	E	1.794 x 10.68	<b>K170G<sup>12</sup></b>					
	15000# 16000#		2254366 1C-2-40	E	1.794 x 10.68	<b>K170G<sup>12</sup></b>					
	13200# FF-941 FF-961			B	1.794 x 10.40	<b>K961L</b>	70.961.12	50.961.12	ST70-7	92.961.12	84.122.05
MC-12	14600# FG-931, FG-933, FG-941, FG-943, FG-952		U-2-54	B	1.794 x 10.40	<b>KG931R</b>	77.931.18	57.931.18	ST70-7	92.931.12	84.122.05
102DL3	16000# 20000# FH-946		01-01-1017 01-01-1079	B	1.794 x 9.19	<b>KH946R</b>	78.946.18	58.946.18	ST70-7	92.946.18	84.122.05
G COACH	16000# 1-160S			B	2.046 x 11.00	<b>K161S</b>			ST70-24		
<b>McNELIUS MTM</b>											
			188033	A	1.810 x 10.56	<b>K126W</b>	70.126.23	50.126.23	ST70-33	91.127.23	84.122.05
<b>MITSUBISHI</b>											
			MK703748	A	1.101 x 7.10	<b>K60U</b>			ST70-34		
<b>NEW FLYER</b>											
	MAN		6313078	J	1.969 x 8.77	<b>K120N</b>			ST70-27		
<b>PETERBILT (See Rockwell / Meritor, Spicer / Dana / Eaton)</b>											
<b>RIDEWELL</b>											
	RSS-232-8K		1660170	B	1.500 x 8.93	<b>K941R</b>	70.941.18	50.941.18	ST70-28		
	RSS-232UM, MM, HM		1660106	B	1.794 x 10.40	<b>KG931R</b>	77.931.18	57.931.18	ST70-7	91.931.18	84.122.05
			16673258034	A	1.810 x 10.56	<b>K127W</b>	70.127.23	50.127.23	ST70-33	91.127.23	84.122.05
	RSS-232-20K		1660189	B	1.999 x 11.21	<b>KH931L</b>	78.931.12	58.931.12	ST70-12	92.931.12	84.931.12
<b>ROCKWELL / MERITOR (Non-Driving Front Steering Axles)</b>											
	12000# 16612, 16613, 16616		123, 144, 152, 186	E	1.607 x 9.75	<b>K125G<sup>12</sup></b>	70.125.07 <sup>12</sup>	50.125.07 <sup>12</sup>	ST70-5		
	12000# 16930, 16931		121	E	1.794 x 10.68	<b>K170G<sup>12</sup></b>					

MODEL	AXLE	YEAR	OEM NO.	PIN TYPE	OEM SPEC	QWIKKIT NO. <sup>1</sup>	PLUSKIT NO. <sup>2</sup>	ECONO KIT NO.	LIP SEAL/ BUSHING DRIVER INSTALLATION TOOL	AXLE SLEEVE USED WITH APE	APE CUTTER KIT USED	
<b>ROCKWELL / MERITOR (Non-Driving Front Steering Axles) CONT.</b>												
	14600# 17100, 17101, 17111, 17801		1309, 1310, 1319	B	1.794 x 10.40	<b>KG931R</b>	77.931.18	57.931.18	ST70-7	92.931.18	84.122.05	
	5000# FA941			A	1.179 x 6.36	<b>K566</b>	70.056.07	50.056.07	ST70-4	91.056.07	84.056.07	
	7000# FC-901 FC-902, FC-903		143, 155	B	1.234 x 7.43	<b>K70D</b>	70.070.04	50.070.04	ST70-10			
	FC-921		1314, 1320	B	1.234 x 7.43	<b>K71D</b>	70.071.04	50.071.04	ST70-10			
	8000# FC-941		1318	B	1.500 x 8.93	<b>K941R</b>	70.941.18	50.941.18	ST70-28			
	9000# FD-901 FD-902, FD-903	1955 to date	138, 142, 154	B	1.434 x 8.50	<b>KD901R</b>	74.901.18	54.901.18	ST70-9			
	10000# FD-961 FD-965		1315, 1470, 1471	B	1.794 x 10.40	<b>K961L</b>	70.961.12	50.961.12	ST70-7	92.961.12	84.122.05	
	11000# FE-900 FE-903, FE-910		123, 144	E	1.607 x 9.75	<b>K125G<sup>12</sup></b>	70.125.07 <sup>12</sup>	50.125.07 <sup>12</sup>	ST70-5			
	12000# FE-970 (Straight Pin)		156, 157	B	1.606 x 8.81	<b>K970R</b>	70.970.18	50.970.18	ST70-13			
	12000# FF-971		1300	B	1.609 x 9.37	<b>K971R</b>			ST70-13			
	12000# FF-901, FF-903		167, 172	B	1.794 x 9.12	<b>K901L</b>	70.901.12	50.901.12	ST70-7			
	12000# FF-921, FF-923		193, 199	B	1.794 x 10.39	<b>K921L</b>	70.921.12	50.921.12	ST70-7			
	16000# FH-901		168, 170	B	1.999 x 11.04	<b>KH901L</b>	78.901.12	58.901.12	ST70-12			
	18000# FL-901		168, 170	B	1.999 x 11.04	<b>KH901L</b>	78.901.12	58.901.12	ST70-12			
	12000# FF-930		121	E	1.794 x 10.68	<b>K170G<sup>12</sup></b>						
	12000# FF-931 FF-932, FF-933 FF-934		195, 1307	B	1.794 x 10.40	<b>K931L</b>	70.931.12	50.931.12	ST70-7	92.961.12	84.122.05	
	1-599 Series	13200# FF-941 FF-942, FF-943 FF-944, FF-945		195, 1307	B	1.794 x 10.40	<b>K931L</b>	70.931.12	50.931.12	ST70-7	92.961.12	84.122.05
	600 Series	13200# FF-941 FF-942, FF-943 FF-944, FF-945		1315, 1470	B	1.794 x 10.40	<b>K961L</b>	70.961.12	50.961.12	ST70-7	92.961.12	84.122.05
	FF-946		R201473	B	1.794 x 10.40	<b>K120R</b>	70.120.18	50.120.18	ST70-7			
	13200# FF-961 FF-962, FF-966 FF-967, FC-965		1315, 1470	B	1.794 x 10.40	<b>K961L</b>	70.961.12	50.961.12	ST70-7	92.961.12	84.122.05	
	12000# FF-981 FF-982, FF-983 FF-984, FF-986 FF-987		1419, 1472	B	1.794 x 8.87	<b>K981R</b>	70.981.18	50.981.18	ST70-7	92.961.12	84.122.05	
	14600# FG-931 FG-933, FG-941 FG-943, FG-952		1309, 1310 1319, 1471	B	1.794 x 10.40	<b>KG931R</b>	77.931.18	57.931.18	ST70-7	92.931.18	84.122.05	
	16000# FH-941 20000# FH-945 FH-946		1424 1420	B	1.794 x 9.19	<b>KH946R</b>	78.946.18	58.946.18	ST70-7	92.946.18	84.122.05	
	18000# FL-931 FL-933, FL-941 FL-943, FH-951		198, 1312	B	1.999 x 11.21	<b>KH931L</b>	78.931.12	58.931.12	ST70-12	92.931.12	84.931.12	

PIN TYPE CHART:			
	<b>A</b> – SINGLE LOCK FLAT		<b>E</b> – TAPERED THREADED
	<b>B</b> – DOUBLE LOCK FLAT		<b>F</b> – TAPERED
	<b>C</b> – SAME SIDE LOCK FLATS		<b>G</b> – STEP THREADED
	<b>H</b> – NO LOCK FLATS		<b>J</b> – SINGLE STEP

1. STEMCO Kaiser QwikKit® feature patented spiral steel bushings. 2. STEMCO Kaiser PlusKit® feature pre-sized steel back bronze bushings. 3. Kit has composite bushings. 4. Modify spindles to receive end plates. 5. Bolt on cap. 6. Threaded cap. 7. Length of STEMCO Kaiser pin is 9 3/4". 8. STEMCO Kaiser pin is longer than OEM. 9. Torque Spec. for king pin nut 230 ft/lbs. 10. Torque Spec. for king pin nut is 300 ft/lbs. 11. Torque Spec. for king pin nut is 406 ft/lbs. 12. Torque Spec. for king pin nut is 350/475 ft/lbs. 13. Includes end caps. 14. Torque Spec. for knuckle attachment bolts is 170-200 ft/lbs. 15. Kit uses special removal tool ST90-1.

## FOR ALL QWIKKIT® – BUSHING "T" HANDLE WRENCHES

TOOL NO.	DESCRIPTION
ST-100-1	Short "T" Handle Wrench
ST-100-2	Long "T" Handle Wrench
100M1-1	Replacement head
Above Wrenches will fit the bushings in most kits. The Following kits do not use wrenches: K80A, K120A, K120N, K150XG, K160A, K700T, K60U, 50.121.08	

TOOL NO.	DESCRIPTION
ST-100-3	Short "T" Handle Wrench
ST-100-4	Long "T" Handle Wrench
100M1-2	Replacement head
Above Wrenches will fit the bushings in the following kits: K50F, K71F, K72F, K80G, K110G, K120G, K122V, K146E, K147E, K180E, K68Z, K69Z	

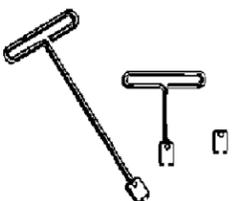

# STEERING KNUCKLE KING PIN KITS

MODEL	AXLE	YEAR	OEM NO.	PIN TYPE	OEM SPEC	QWIKKIT NO. <sup>1</sup>	PLUSKIT NO. <sup>2</sup>	ECONO KIT NO.	LIP SEAL/ BUSHING DRIVER INSTALLATION TOOL	AXLE SLEEVE USED WITH APE	APE CUTTER KIT USED
<b>ROCKWELL / MERITOR (Non-Driving Front Steering Axles) CONT.</b>											
	6000# MFS-06		R201478	A	1.234 x 6.78	<b>K60R</b>			ST70-3	91.060.18	84.060.18
	7000# MFS-07		R201479, R201483	B	1.499 x 7.15	<b>K70R</b>	70.070.18	50.070.18	ST70-28		
	8000# MFS-08		R201474	B	1.499 x 7.50	<b>K80R</b>	70.080.18	50.080.18	ST70-28		
	10000# MFS-10		R201470	B	1.794 x 10.40	<b>K961L</b>	70.961.12	50.961.12	ST70-7	92.961.12	84.122.05
	12000# MFS-12122A, MFS-12143A, MFS-12153A		R201315, R201470	B	1.794 x 10.40	<b>K961L</b>	70.961.12	50.961.12	ST70-7	92.961.12	84.122.05
	12000# MFS-12122D, MFS-12143D, MFS-12144D		R201419, R201472	B	1.794 x 8.87	<b>K981R</b>	70.981.18	50.981.18	ST70-7	92.961.12	84.122.05
	12000# MFS-12144A, MFS-12155A		R201473	B	1.794 x 10.40	<b>K120R</b>	70.120.18	50.120.18	ST70-7		
	12000# MFS-12		R201608	B	1.794 x 9.02	<b>K131R</b>			ST70-7		
	13000# MFS-13122D, MFS-13143D, MFS-13144D		R201419, R201472	B	1.794 x 8.87	<b>K981R</b>	70.981.18	50.981.18	ST70-7	92.961.12	84.122.05
	13000# MFS-131015, MFS-13143A, MFS-13144A		R201471	B	1.794 x 10.40	<b>KG931R</b>	77.931.18	57.931.18	ST70-7	92.931.18	84.122.05
	13000# MFS-13		R201608	B	1.794 x 9.02	<b>K131R</b>			ST70-7		
	13000# MFS-13		R201488	B	1.794 x 8.84	<b>K132R</b>			ST70-7		
	13000# MFS-13		R201609	B	1.794 x 9.02	<b>K130R</b>			ST70-7		
	14000# MFS-141015, MFS-14143A, MFS-14153A		R201471	B	1.794 x 10.40	<b>KG931R</b>	77.931.18	57.931.18	ST70-7	92.931.18	84.122.05
	14000# MFS-14		R201609	B	1.794 x 9.02	<b>K130R</b>			ST70-7		
	16000# MFS-161015, MFS-16122A, MFS-16143A		R201475	B	1.999 x 11.21	<b>K180R</b>	70.180.18	50.180.18	ST70-12	92.180.18	84.931.12
	16000# MFS-16133A		R201476	B	1.999 x 11.21	<b>K181R</b>	70.181.18	50.181.18	ST70-12	92.931.12	84.931.12
	18000# MFS-18133ANK		R201482	B	1.999 x 10.79	<b>K200R</b>			ST70-12		
	18000# MFS-MFS-18133ANN		R201476	B	1.999 x 11.21	<b>K181R</b>	70.181.18	50.181.18	ST70-12	92.931.12	84.931.12
	18000# MFS-18143A		R201475	B	1.999 x 11.21	<b>K180R</b>	70.180.18	50.180.18	ST70-12	92.180.18	84.931.12
	20000# MFS-20133ANN		R201476	B	1.999 x 11.21	<b>K181R</b>	70.181.18	50.181.18	ST70-12	92.931.12	84.931.12

MODEL	AXLE	YEAR	OEM NO.	PIN TYPE	OEM SPEC	QWIKKIT NO. <sup>1</sup>	PLUSKIT NO. <sup>2</sup>	ECONO KIT NO.	LIP SEAL/ BUSHING DRIVER INSTALLATION TOOL	AXLE SLEEVE USED WITH APE	APE CUTTER KIT USED
<b>ROCKWELL / MERITOR (Non-Driving Front Steering Axles) CONT.</b>											
	20000# MFS-20133ANK		R201482	B	1.999 x 10.79	<b>K200R</b>			ST70-12		
	20000# MFS-20142A		R201477	B	1.999 x 11.21	<b>KH931L</b>	78.931.12	58.931.12	ST70-12	92.931.12	84.931.12
<b>SPICER / DANA / EATON</b>											
02 CODES	6000# 02-ADA, 8000# 02-ADB, 02-ADV, 02-ADW		166027C91, 101KK111	B	1.359 x 7.97	<b>K102I</b>	70.102.09	50.102.09	ST70-2	92.102.09	84.103.19
	8000# 02-AEM,	Before 10/2002	101KK111	B	1.359 x 7.97	<b>K102I</b>	70.102.09	50.102.09	ST70-2	92.102.09	84.103.19
	8000# 02-AEM, 02-AHA, 02-AGZ, 02-ADZ, 02-AGN	10/2002-Present	329182	C	1.359 x 7.97	<b>K103S</b>	70.103.19	50.103.19	ST70-2	93.103.19	84.103.19
	8000# 02-ATK		R201604	B	1.499 x 7.50	<b>K80R</b>	70.080.18	50.080.18	ST70-28		
	10000# 02-ADC, 02-ADL		1668411C91	B	1.921 x 9.87	<b>K120I<sup>8</sup></b>	70.120.09 <sup>8</sup> , 70.120.99 <sup>8</sup>	50.120.09 <sup>8</sup>	ST70-19	92.120.09	84.147.05
	12000# 02-ADD, 02-ADG, 02-ADN, 02-ADP	1989 to Date	1668411C91, 120KK100	B	1.921 x 9.87	<b>K120I<sup>8</sup></b>	70.120.09 <sup>8</sup> , 70.120.99 <sup>8</sup>	50.120.09 <sup>8</sup>	ST70-19	92.120.09	84.147.05
	02-AEA		806355	A	1.625 x 9.19	<b>K120E</b>	70.120.05	50.120.05	ST70-6	91.120.05	84.120.05
	12000# 02-AED, 02-AEG		816787, 823078, 328344, 328342	A	1.794 x 9.05	<b>K122E</b>	70.122.05, 70.122.95 <sup>9</sup>	50.122.05	ST70-7	91.122.05	84.122.05
	12000# 02-AGA		328346, 328348	C	1.794 x 9.05	<b>K123E</b>	70.123.05	50.123.05	ST70-7	93.123.05	84.122.05
	12000# 02-ARK, 02-ARL, 02-ASB, 02-ASD		2500542C91	B	1.794 x 8.87	<b>K981R</b>	70.981.18	50.981.18	ST70-7	92.961.12	84.122.05
	12000# 02-ARA, 02-ARV, 02-ARW, 02-ASX		1665531C91	B	1.794 x 10.40	<b>K961L</b>	70.961.12	50.961.12	ST70-7	92.961.12	84.122.05
	02-ARG			B	1.794 x 10.40	<b>KG931R</b>	77.931.18	57.931.18	ST70-7	92.931.18	84.122.05
	12000# 02-ASV, 02-ASW, 02-AUB, 02-AUC, 02-AUD		60961-009, 60961-039, 60961-040					50.121.08	ST70-32		
	14000# 02-ADE, 02-ADT, 02-AES, 02-AET, 02-AGL, 02-AGV	1990 to Date	140KK100, 329022	B	2.046 x 10.12	<b>K141S<sup>8</sup></b>	70.141.19 <sup>8</sup>	50.141.19 <sup>8</sup>	ST70-24		
	14600# 02-AEZ, 02-AGB, 02-AGC, 02-AGE		328347, 328349	C	1.872 x 9.05	<b>K147E</b>	70.147.05	50.147.05	ST70-23	93.147.05	84.147.05
	16000# 02-ADH, 02-AEU, 02-AEV, 02-AEW, 18000# 02-ADJ, 20000# 02-ADK		220KK100, 1685405C91	B	2.046 x 11.00	<b>K160S</b>	70.160.19	50.160.19	ST70-24	92.160.19	84.931.12
	18000# 02-ARU		2505495C91	B	1.999 x 11.21	<b>K180R</b>	70.180.18	50.180.18	ST70-12	92.180.18	84.931.12
	18000# 02-ARZ, 02-ARY			B	1.999 x 11.21	<b>K181R</b>	70.181.18	50.181.18	ST70-12	92.931.12	84.931.12

PIN TYPE CHART:			
	<b>A</b> – SINGLE LOCK FLAT		<b>E</b> – TAPERED THREADED
	<b>B</b> – DOUBLE LOCK FLAT		<b>F</b> – TAPERED
	<b>C</b> – SAME SIDE LOCK FLATS		<b>G</b> – STEP THREADED
	<b>H</b> – NO LOCK FLATS		<b>J</b> – SINGLE STEP

1. STEMCO Kaiser QwikKit® feature patented spiral steel bushings. 2. STEMCO Kaiser PlusKit® feature pre-sized steel back bronze bushings. 3. Kit has composite bushings. 4. Modify spindles to receive end plates. 5. Bolt on cap. 6. Threaded cap. 7. Length of STEMCO Kaiser pin is 9 3/4". 8. STEMCO Kaiser pin is longer than OEM. 9. Torque Spec. for king pin nut 230 ft/lbs. 10. Torque Spec. for king pin nut is 300 ft/lbs. 11. Torque Spec. for king pin nut is 406 ft/lbs. 12. Torque Spec. for king pin nut is 350/475 ft/lbs. 13. Includes end caps. 14. Torque Spec. for knuckle attachment bolts is 170-200 ft/lbs. 15. Kit uses special removal tool ST90-1.

## FOR ALL QWIKKIT® – BUSHING "T" HANDLE WRENCHES

TOOL NO.	DESCRIPTION
ST-100-1	Short "T" Handle Wrench
ST-100-2	Long "T" Handle Wrench
100M1-1	Replacement head
Above Wrenches will fit the bushings in most kits. The Following kits do not use wrenches: K80A, K120A, K120N, K150XG, K160A, K700T, K60U, 50.121.08	

TOOL NO.	DESCRIPTION
ST-100-3	Short "T" Handle Wrench
ST-100-4	Long "T" Handle Wrench
100M1-2	Replacement head
Above Wrenches will fit the bushings in the following kits: K50F, K71F, K72F, K80G, K110G, K120G, K122V, K146E, K147E, K180E, K68Z, K69Z	

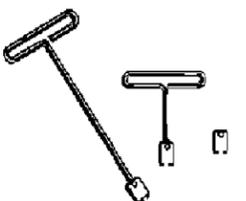

# STEERING KNUCKLE KING PIN KITS

MODEL	AXLE	YEAR	OEM NO.	PIN TYPE	OEM SPEC	QWIKKIT NO. <sup>1</sup>	PLUSKIT NO. <sup>2</sup>	ECONO KIT NO.	LIP SEAL/ BUSHING DRIVER INSTALLATION TOOL	AXLE SLEEVE USED WITH APE	APE CUTTER KIT USED
<b>SPICER / DANA / EATON CONT.</b>											
D CODES	6000# D600, 7000# D700, 8500# D850		329182	C	1.359 x 7.97	<b>K103S</b>	70.103.19	50.103.19	ST70-2	93.103.19	84.103.19
	8000# D800	Before 10/2002	101KK111	B	1.359 x 7.97	<b>K102I</b>	70.102.09	50.102.09	ST70-2	92.102.09	84.103.19
	8000# D800F	10/2002-Present	329182	C	1.359 x 7.97	<b>K103S</b>	70.103.19	50.103.19	ST70-2	93.103.19	84.103.19
	20000# D2000F, 22000# D2200F		331434	B	2.046 x 10.07	<b>K200S</b>			ST70-24		
	20000# D2000F, 22000# D2200F		331435	C	2.046 x 10.07	<b>K201S</b>			ST70-24	93.201.19	84.931.12
E CODES	10000# E1000/W, 12000# E1200/W, E1201/W, 13200# E1320/W		823078, 328344, 328342	A	1.794 x 9.05	<b>K122E</b>	70.122.05	50.122.05	ST70-7	91.122.05	84.122.05
	12000# E1203I		328346, 328348	C	1.794 x 9.05	<b>K123E</b>	70.123.05	50.123.05	ST70-7	93.123.05	84.122.05
	14600# E1460/W		824530, 824920, 328345, 328343, 329404, 329405	A	1.872 x 9.05	<b>K146E</b>	70.146.05	50.146.05	ST70-23	91.146.05	84.147.05
	10000# E1002/W, 12000# E1202/W, 13200# E1322/W, 14600# E1462/W		328347, 328349	C	1.872 x 9.05	<b>K147E</b>	70.147.05	50.147.05	ST70-23	93.147.05	84.147.05
	10000# E1002/W, 12000# E1202/W, 13000# E1302I, TOP DEAD CENTER MOUNTED ADB		503700	C	1.872 x 8.66	<b>K145E</b>			ST70-23		
EFA CODES	12000# EFA12F3		806356, 1005632	A	1.625 x 9.19	<b>K121E</b>	70.121.05	50.121.05	ST70-6		
	10000# EFA10F5, 12000# EFA12F4, 13200# EFA13F5		806355, 815984, 1008431	A	1.625 x 9.19	<b>K120E</b>	70.120.05	50.120.05	ST70-6	91.120.05	84.120.05
	18000# EFA18F3, EFA18F4, 20000# EFA20F4, 22000# EFA22T2, EFA22T5, 24000# EFA24T2, EFA24T5		811525, 1008500, 329432, 329433, 329434	A	1.872 x 9.97	<b>K180E</b>	70.180.05	50.180.05	ST70-23	91.180.05	84.147.05
I CODES	5000# I-050		473695C91	A	1.359 x 7.97	<b>K101I</b>	70.101.09	50.101.09	ST70-2	91.101.09	84.103.19
	6000# I-060		473695C91	A	1.359 x 7.97	<b>K101I</b>	70.101.09	50.101.09	ST70-2	91.101.09	84.103.19
	6000# I-60S, I-60SE, I-61		166027C91, 101KK111	B	1.359 x 7.97	<b>K102I</b>	70.102.09	50.102.09	ST70-2	92.102.09	84.103.19
	7500# I-075		473695C91	A	1.359 x 7.97	<b>K101I</b>	70.101.09	50.101.09	ST70-2	91.101.09	84.103.19
	8000# I-080		473695C91	A	1.359 x 7.97	<b>K101I</b>	70.101.09	50.101.09	ST70-2	91.101.09	84.103.19
	8000# I-80S, I-80SE		166027C91, 101KK111	B	1.359 x 7.97	<b>K102I</b>	70.102.09	50.102.09	ST70-2	92.102.09	84.103.19
	9000# I-090	Before Aug 1981	470752C91, 483095C91	A	1.609 x 9.16	<b>K309I</b>	70.309.09	50.309.09	ST70-5		
	9000# I-090	After Aug 1981	586806C91	B	1.609 x 9.16	<b>K310I</b>	70.310.09	50.310.09	ST70-5		

PIN TYPE CHART:					
	<b>A</b> – SINGLE LOCK FLAT		<b>E</b> – TAPERED THREADED		<b>G</b> – STEP THREADED
	<b>B</b> – DOUBLE LOCK FLAT		<b>H</b> – NO LOCK FLATS		<b>J</b> – SINGLE STEP
	<b>C</b> – SAME SIDE LOCK FLATS		<b>F</b> – TAPERED		

1. STEMCO Kaiser QwikKit® feature patented spiral steel bushings. 2. STEMCO Kaiser PlusKit® feature pre-sized steel back bronze bushings. 3. Kit has composite bushings. 4. Modify spindles to receive end plates. 5. Bolt on cap. 6. Threaded cap. 7. Length of STEMCO Kaiser pin is 9 3/4". 8. STEMCO Kaiser pin is longer than OEM. 9. Torque Spec. for king pin nut 230 ft/lbs. 10. Torque Spec. for king pin nut is 300 ft/lbs. 11. Torque Spec. for king pin nut is 406 ft/lbs. 12. Torque Spec. for king pin nut is 350/475 ft/lbs. 13. Includes end caps. 14. Torque Spec. for knuckle attachment bolts is 170-200 ft/lbs. 15. Kit uses special removal tool ST90-1.

MODEL	AXLE	YEAR	OEM NO.	PIN TYPE	OEM SPEC	QWIKKIT NO. <sup>1</sup>	PLUSKIT NO. <sup>2</sup>	ECONO KIT NO.	LIP SEAL/ BUSHING DRIVER INSTALLATION TOOL	AXLE SLEEVE USED WITH APE	APE CUTTER KIT USED
<b>SPICER / DANA / EATON CONT.</b>											
I CODES (cont.)	10000# I-100S, I-100SA, I-100SG		1668411C91	B	1.921 x 9.87	<b>K120I</b>	70.120.09 <sup>a</sup> , 70.120.99 <sup>b</sup>	50.120.09 <sup>a</sup>	ST70-19	92.120.09	84.147.05
	10800# I-108 All except code 02309		399942C93, 1658934C91, 586808C91	B	1.609 x 9.66	<b>K140I</b>	70.140.09	50.140.09	ST70-5	92.140.09	84.120.05
	10800# I-108 For code 02309		586806C91	B	1.609 x 9.16	<b>K310I</b>	70.310.09	50.310.09	ST70-5		
	12000# I-120 All except code 02309		399942C93, 1658934C91, 586808C91	B	1.609 x 9.66	<b>K140I</b>	70.140.09	50.140.09	ST70-5	92.140.09	84.120.05
	12000# I-120 For code 02309		586806C91	B	1.609 x 9.16	<b>K310I</b>	70.310.09	50.310.09	ST70-5		
	12000# I-120S, I-120SE, I-120SGL	1989 to date	1668411C91, 120KK100	B	1.921 x 9.87	<b>K120I</b>	70.120.09 <sup>a</sup> , 70.120.99 <sup>b</sup>	50.120.09 <sup>a</sup>	ST70-19	92.120.09	84.147.05
	13200# I-132		588808C91, 1658394C91	B	1.609 x 9.66	<b>K140I</b>	70.140.09	50.140.09	ST70-5	92.140.09	84.120.05
	14000# I-140S, I-140SE, I-140W, I-132SE	1990 to date	140KK100, 329022	B	2.046 x 10.12	<b>K141S</b>	70.141.19 <sup>a</sup>	50.141.19 <sup>a</sup>	ST70-24		
	14600# I-146S, I-146SA		120KK102	B	1.860 x 10.75	<b>K146S</b>					
	16000# I-160S, I-160W, 18000# I-180S, I-180W, 20000# I-200S, I-200W, 22000# I-220S, I-220W		220KK100, 1658405C91, 329023	B	2.046 x 11.00	<b>K160S</b>	70.160.19	50.160.19	ST70-24	92.160.19	84.931.12
16000# I-160S, I-160SB for MCI Buses only		161KK100	B	2.046 x 11.00	<b>K161S</b>			ST70-24			
I-161		329116	B	1.794 x 11.00	<b>K162S</b>			ST70-7			
<b>STERLING (SEE ROCKWELL / MERITOR, SPICER / DANA / EATON)</b>											
<b>VOLVO</b>											
	9000# FM9		85108338	E	2.360 x 8.92	<b>K536M</b> <sup>15</sup>					
	12000# FM12		85108338	E	2.360 x 8.92	<b>K536M</b> <sup>15</sup>					
	12000# FXL12		301S053	E	2.360 x 8.92	<b>K536M</b> <sup>15</sup>					
	14600# FXL14.6		301S053	E	2.360 x 8.92	<b>K536M</b> <sup>15</sup>					
	18000# FXL18		301S053	E	2.360 x 8.92	<b>K536M</b> <sup>15</sup>					
	20000# FXL20		301S053	E	2.360 x 8.92	<b>K536M</b> <sup>15</sup>					
	23000# FXL23		301S053	E	2.360 x 8.92	<b>K536M</b> <sup>15</sup>					
	10000# VF10, 12000# VF12, 12500# VF125, FAX5.5, FAX5.7		3130711, V3090267	E	1.777 x 8.62	<b>K122V</b>					
	VF14, VF16, VF18		3090266	E	1.969 x 9.88	<b>K140V</b>					
			3093704	B	1.794 x 8.87	<b>K981R</b>	70.981.18	50.981.18	ST70-7	92.961.12	84.122.05
			V1112810	A	1.625 x 9.19	<b>K120E</b>	70.120.05	50.120.05	ST70-6	91.120.05	84.120.05
			85106184	A	1.794 x 9.05	<b>K122E</b>	70.122.05	50.122.05	ST70-7	91.122.05	84.122.05

## FOR ALL QWIKKIT® – BUSHING "T" HANDLE WRENCHES

TOOL NO.	DESCRIPTION
ST-100-1	Short "T" Handle Wrench
ST-100-2	Long "T" Handle Wrench
100M1-1	Replacement head
Above Wrenches will fit the bushings in most kits. The Following kits do not use wrenches: K80A, K120A, K120N, K150KG, K160A, K700T, K60U, 50.121.08	

TOOL NO.	DESCRIPTION
ST-100-3	Short "T" Handle Wrench
ST-100-4	Long "T" Handle Wrench
100M1-2	Replacement head
Above Wrenches will fit the bushings in the following kits: K50F, K71F, K72F, K80G, K110G, K120G, K122V, K146E, K147E, K180E, K68Z, K69Z	

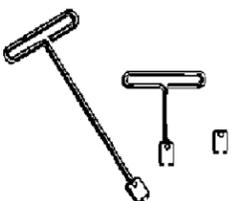

# STEERING KNUCKLE KING PIN KITS

MODEL	AXLE	YEAR	OEM NO.	PIN TYPE	OEM SPEC	QWIKKIT NO. <sup>1</sup>	PLUSKIT NO. <sup>2</sup>	ECONO KIT NO.	LIP SEAL/ BUSHING DRIVER INSTALLATION TOOL	AXLE SLEEVE USED WITH APE	APE CUTTER KIT USED
<b>WATSON &amp; CHALIN</b>											
	SL8K w/ MERITOR AXLE		SRK103	B	1.500 x 8.93	<b>K941R</b>	70.941.18	50.941.18	ST70-28		
	SL8K w/ WESTPORT AXLE		SRK115	B	1.500 x 8.93	<b>K81W</b>			ST70-28		
	1100 Series w/ MERITOR AXLE		SRK102	B	1.794 x 10.40	<b>K961L</b>	70.961.12	50.961.12	ST70-7	91.961.12	84.122.05
	1100 Series w/ WESTPORT AXLE		SRK98 SRK112	B	1.794 x 10.40	<b>K130W</b>	70.130.23	50.130.23	ST70-7	91.961.12	84.122.05
	SL2089, SL2090, SLTL2095, STL2096 w/ MERITOR AXLE		SRK105	B	1.999 x 11.21	<b>KH931L</b>	78.931.12	58.931.12	ST70-12	92.931.12	84.931.12
	SL2089, SL2090, SLTL2095, STL2096 w/ WESTPORT AXLE		SRK120	B	1.999 x 11.21	<b>K181R</b>	70.181.18	50.181.18	ST70-12	92.931.12	84.931.12
<b>WHITE / WESTPORT</b>											
Trend Models	7000#	1966-1967		B	1.234 x 7.43	<b>K70D</b>	70.070.04	50.070.04	ST70-10		
	F4W-0800		143698-0040	B	1.300 x 7.75	<b>K72F</b>	70.072.06	50.072.06	ST70-17		
	F3W-1200 F5W-1200 F6W-1200 (12000#)	1952-1975	216446	A	1.810 x 10.78	<b>K120W</b>					
	F3W-1300, F3W-1400, F3W-1600, F6W-1300, F6W-1400, F6W-1600		143698-0052	A	1.810 x 10.56	<b>K127W</b>	70.127.23	50.127.23	ST70-33	91.127.23	84.122.05
	F3W-125 (12000#)	1975 to date	143698-0001	A	1.810 x 10.56	<b>K125W</b>	70.125.23	50.125.23	ST70-33		
	F3W-140, F5W-140, F6W-140 (14000#)	1966-1975	216446	A	1.810 x 10.78	<b>K120W</b>					
	F3W, F6W, 1200 Series	1975 to date	37090-5005 143698-0051	A	1.810 x 10.56	<b>K126W</b>	70.126.23	50.126.23	ST70-33	91.127.23	84.122.05
	F3W, F6W 1400 Series	1975 to date	217175 143698-0001	A	1.810 x 10.56	<b>K125W</b>	70.125.23	50.125.23	ST70-33		
	F0W-1800, F3W-2000, F2W-2000D		143698-0018	B	1.999 x 11.21	<b>K181R</b>	70.181.18	50.181.18	ST70-12	92.931.12	84.931.12
	9000# (FD-901)	1960-1967	138, 142, 154	B	1.434 x 8.50	<b>KD901R</b>	74.901.18	54.901.18	ST70-9		
	12000# (FE-900)	1955-1965	857328	E	1.609 x 9.75	<b>K125G<sup>12</sup></b>	70.125.07 <sup>12</sup>	50.125.07 <sup>12</sup>	ST70-5		
	16000# (FH-901)	1965-1975	168, 170	B	1.999 x 11.04	<b>KH901L</b>	78.901.12	58.901.12	ST70-9		
	18000# (FL-901)	1965-1975	1720728 1739844	B	1.999 x 11.04	<b>KH901L</b>	78.901.12	58.901.12	ST70-12		
Westport Axle	WS1637090-4405		143698-0051	A	1.811 x 10.56	<b>K126W</b>	70.126.23	50.126.23	ST70-33	91.127.23	84.122.05
	F5W0900		143698-0053	B	1.606 x 9.08	<b>K96F</b>	70.096.06	50.096.06	ST70-13		
<b>WORKHORSE</b>											
			8006372	A	1.179 x 6.36	<b>K58G</b>	70.058.07		ST70-4		
			8803055	A	1.179 x 6.36	<b>K56G</b>	70.056.07	50.056.07	ST70-4	91.056.07	84.056.07
			8003056	A	1.179 x 7.31	<b>K50W</b>			ST70-4	91.050.23	84.056.07
			8007232	B	1.300 x 7.75	<b>K72F</b>	70.072.06	50.072.06	ST70-17		

PIN TYPE CHART:					
	<b>A</b> – SINGLE LOCK FLAT		<b>E</b> – TAPERED THREADED		<b>H</b> – NO LOCK FLATS
	<b>B</b> – DOUBLE LOCK FLAT		<b>F</b> – TAPERED		<b>J</b> – SINGLE STEP
	<b>C</b> – SAME SIDE LOCK FLATS		<b>G</b> – STEP THREADED		

1. STEMCO Kaiser QwikKit® feature patented spiral steel bushings. 2. STEMCO Kaiser PlusKit® feature pre-sized steel back bronze bushings. 3. Kit has composite bushings. 4. Modify spindles to receive end plates. 5. Bolt on cap. 6. Threaded cap. 7. Length of STEMCO Kaiser pin is 9 3/4". 8. STEMCO Kaiser pin is longer than OEM. 9. Torque Spec. for king pin nut is 230 ft/lbs. 10. Torque Spec. for king pin nut is 300 ft/lbs. 11. Torque Spec. for king pin nut is 406 ft/lbs. 12. Torque Spec. for king pin nut is 350/475 ft/lbs. 13. Includes end caps. 14. Torque Spec. for knuckle attachment bolts is 170-200 ft/lbs. 15. Kit uses special removal tool ST90-1.

# BUS STEERING KNUCKLE KING PIN KITS

MODEL	AXLE	YEAR	OEM NO.	PIN TYPE	OEM SPEC	QWIKKIT NO. <sup>1</sup>	PLUSKIT NO. <sup>2</sup>	ECONO KIT NO.	LIP SEAL/ BUSHING DRIVER INSTALLATION TOOL	AXLE SLEEVE USED WITH APE	APE CUTTER KIT USED
<b>BLUEBIRD</b>											
All American	Airtex Softek 649505-0004		00063311 LT SIDE 00063312 RT SIDE 00063313 BT SIDES					50.121.08	ST70-32		
	12000# FF-942			B	1.794 x 10.40	<b>K931L</b>	70.931.12	50.931.12	ST70-7	92.961.12	84.122.05
	12000# I-120S, I-120SG, I-120SGL		8305203	B	1.921 x 9.87	<b>K120I<sup>8</sup></b>	70.120.09 <sup>8</sup> 70.120.99 <sup>8a</sup>	50.120.09 <sup>8</sup>	ST70-19	92.120.09	84.147.05
TC2000	12000# I-120SA, I-120IS, I-126SA, I-126IS 14600# I-146SA	1990-	4294716	B	1.859 x 10.75	<b>K146S</b>					
	14000# I-140S I-140SG, I-146		8305211	B	2.046 x 10.12	<b>K141S<sup>9</sup></b>	70.141.19 <sup>9</sup>	50.141.19 <sup>9</sup>	ST70-24		
	10,800#	1988-1989	2156784 4293270	B	1.609 x 9.66	<b>K140I</b>	70.140.09	50.140.09	ST70-5	92.140.09	84.120.05
Rockwell Axles	12,000-13,200# FF-934, FF-942, FF-944		195, 1307	B	1.794 x 10.40	<b>K931L</b>	70.931.12	50.931.12	ST70-7	92.961.12	84.122.05
Uses Lock Pin Sizes 3.68 & 3.25	13,200# FF-961, FF-967		1315 4280855	B	1.794 x 10.40	<b>K961L</b>	70.961.12	50.961.12	ST70-7	92.961.12	84.122.05
	14,600# FG-941, FG-943		1309 1310	B	1.794 x 10.40	<b>KG931R</b>	77.931.18	57.931.18	ST70-7	92.931.18	84.122.05
<b>FORD</b>											
	7000# Hyd. Brakes	1967-1988	C7TZ-3111A	A	1.231 x 8.90	<b>K70F<sup>5</sup></b>	70.073.06	50.073.06	ST70-3		
	7000-9000# Air Brakes	1975-1988	D6TZ-3111A	B	1.433 x 8.25	<b>K75F<sup>5</sup></b>	70.075.06 <sup>5</sup>	50.075.06 <sup>5</sup>	ST70-9		
	7000-9000# Air Brakes	1989-	E9HZ-3111C	B	1.433 x 8.25	<b>K76F<sup>5</sup></b>	70.076.06 <sup>5</sup>	50.076.06 <sup>5</sup>	ST70-9		
	9000# Hyd. Brakes	1960-1983	D1HZ-3111A C2TZ-3111G	B	1.434 x 8.50	<b>KD901R</b>	74.901.18	54.901.18	ST70-9		
	9000# Air Brakes	1975-1988	D6HZ-3111B	B	1.606 x 9.07	<b>K95F<sup>5</sup></b>	70.095.06 <sup>5</sup>	50.095.06 <sup>5</sup>	ST70-13		
	9000# Air Brakes	1989-	E9HZ-3111B	B	1.606 x 9.07	<b>K96F<sup>5</sup></b>	70.096.06 <sup>5</sup>	50.096.06 <sup>5</sup>	ST70-9		
<b>GILLIG</b>											
	14600# FG-931		1309, 1310 1319, 1471	B	1.794 x 10.40	<b>KG931R</b>	77.931.18	57.931.18	ST70-7	92.931.18	84.122.05
	16000# FH-946		1420, 1424	B	1.794 x 9.19	<b>KH946R</b>	78.946.18	58.946.18	ST70-7	92.946.18	84.122.05
<b>GMC COACH</b>											
Transit Coach	7000#		2470621	B	1.234 x 7.43	<b>K70D</b>	70.070.04	50.070.04	ST70-10		
	12000#		2362900 2237497	E	1.609 x 9.75	<b>K125G<sup>12</sup></b>	70.125.07 <sup>12</sup>	50.125.07 <sup>12</sup>	ST70-5		
	15000# 16000#		2254366 IC-2-40	E	1.794 x 10.68	<b>K170G<sup>12</sup></b>					

## FOR ALL QWIKKIT® – BUSHING “T” HANDLE WRENCHES

TOOL NO.	DESCRIPTION
ST-100-1	Short "T" Handle Wrench
ST-100-2	Long "T" Handle Wrench
100M1-1	Replacement head
Above Wrenches will fit the bushings in most kits. The Following kits do not use wrenches: K80A, K120A, K120N, K150KG, K160A, K700T, K60U, 50.121.08	

TOOL NO.	DESCRIPTION
ST-100-3	Short "T" Handle Wrench
ST-100-4	Long "T" Handle Wrench
100M1-2	Replacement head
Above Wrenches will fit the bushings in the following kits: K50F, K71F, K72F, K80G, K110G, K120G, K122V, K146E, K147E, K180E, K68Z, K69Z	

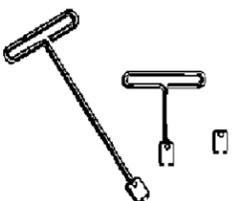

# BUS STEERING KNUCKLE KING PIN KITS

MODEL	AXLE	YEAR	OEM NO.	PIN TYPE	OEM SPEC	QWIKKIT NO. <sup>1</sup>	PLUSKIT NO. <sup>2</sup>	ECONO KIT NO.	LIP SEAL/ BUSHING DRIVER INSTALLATION TOOL	AXLE SLEEVE USED WITH APE	APE CUTTER KIT USED
<b>INTERNATIONAL / NAVISTAR</b>											
	6000#, I-60S (02-ADA)		1660271C92	B	1.359 x 7.97	<b>K102I</b>	70.102.09	50.102.09	ST70-2	92.102.09	84.103.19
	8000#, I-80S (02-ADB)		1660271C92	B	1.359 x 7.97	<b>K102I</b>	70.102.09	50.102.09	ST70-2	92.102.09	84.103.19
	10,000#, I-100S (02-ADC) 12,000#, I-120S (02-ADD)			B	1.921 x 9.87	<b>K120I*</b>	70.120.09 <sup>8</sup> 70.120.99 <sup>3, 8</sup>	50.120.09 <sup>8</sup>	ST70-19	92.120.09	84.147.05
	14,000#, I-140S (02-ADE) (02-AGV)		1668412C91	B	2.046 x 10.12	<b>K141S*</b>	70.141.19 <sup>8</sup>	50.141.19 <sup>8</sup>	ST70-24		
<b>MAN</b>											
	V8-65C-02	1993	81-44205-6013 6313078	J	1.969 x 8.77	<b>K120N</b>			ST70-27		
<b>MCI</b>											
MC-7, MC-8, MC-9	15000# 16000#		2254366 IC-2-40	E	1.794 x 10.68	<b>K170G<sup>12</sup></b>					
	13200# FF-941, FF-961			B	1.794 x 10.40	<b>K961L</b>	70.961.12	50.961.12	ST70-7	92.961.12	84.122.05
MC-12	14600# FG-931		U-2-54	B	1.794 x 10.40	<b>KG931R</b>	77.931.18	57.931.18	ST70-7	92.931.18	84.122.05
102DL3	16000# 20000# FH-946		01-01-1017 01-01-1079	B	1.794 x 9.19	<b>KH946R</b>	78.946.18	58.946.18	ST70-7	92.946.18	84.122.05
G Coach	16000# I-160S			B	2.046 x 11.00	<b>K161S</b>			ST70-24		
<b>NEO PLAN</b>											
	I-161		329116	B	1.794 x 11.00	<b>K162S</b>			ST70-7		
<b>NEW FLYER</b>											
	MAN		6313078	J	1.969 x 8.77	<b>K120N</b>			ST70-27		
<b>ROCKWELL / MERITOR</b>											
	14,600# 17100, 17101, 17111, 17801		R201309 R201310 R201319 R201471	B	1.794 x 10.40	<b>KG931R</b>	77.931.18	57.931.18	ST70-7	92.931.18	84.122.05
	8000# MFS-08		R201474	B	1.500 x 7.50	<b>K80R</b>	70.080.18	50.080.18	ST70-28		
	12000# FF-931, FF-932, FF-933, FF-934		R200195 R201307	B	1.794 x 10.40	<b>K931L</b>	70.931.12	50.931.12	ST70-7	92.961.12	84.122.05
1-599 SERIES	13200# FF-941, FF-942, FF-943, FF-944, FF-945		R200195 R201307	B	1.794 x 10.40	<b>K931L</b>	70.931.12	50.931.12	ST70-7	92.961.12	84.122.05
600 SERIES	13200# FF-941, FF-942, FF-943, FF-944, FF-945		R201315 R201470	B	1.794 x 10.40	<b>K961L</b>	70.961.12	50.961.12	ST70-7	92.961.12	84.122.05
	13200# FF-961, FF-962, FF-966, FF-967, FC-965		R201315 R201470	B	1.794 x 10.40	<b>K961L</b>	70.961.12	50.961.12	ST70-7	92.961.12	84.122.05

MODEL	AXLE	YEAR	OEM NO.	PIN TYPE	OEM SPEC	QWIKKIT NO. <sup>1</sup>	PLUSKIT NO. <sup>2</sup>	ECONO KIT NO.	LIP SEAL/ BUSHING DRIVER INSTALLATION TOOL	AXLE SLEEVE USED WITH APE	APE CUTTER KIT USED
<b>ROCKWELL / MERITOR CONT.</b>											
	14600#, FG-931 FG-933, FG-941, FG-943, FG-952		R201309 R201310 R201319 R201471	B	1.794 x 10.40	<b>KG931R</b>	77.931.18	57.931.18	ST70-7	92.931.18	84.122.05
	16000# FH-941, 20000# FH-945, FH-946		R201420 R201424	B	1.794 x 9.19	<b>KH946R</b>	78.946.18	58.946.18	ST70-7	92.946.18	84.122.05
	18000# FL-931, FL-933, FL-941, FL-943, FL-951		R200198 R201312	B	1.999 x 11.21	<b>KH931L</b>	78.931.12	58.931.12	ST70-12	92.931.12	84.931.12
<b>THOMAS</b>											
ER-Series School Bus Chassis; Rear Engine			8314171	B	1.359 x 7.97	<b>K102I</b>	70.102.09	50.102.09	ST70-2	92.102.09	84.103.19
	13,200# FF-932		1307	B	1.794 x 10.40	<b>K931L</b>	70.931.12	50.931.12	ST70-7	92.961.12	84.122.05
	14,600# FG-941, FG-944		1309 1310	B	1.794 x 10.40	<b>KG931R</b>	77.931.18	57.931.18	ST70-7	92.931.18	84.122.05
	AF-10.0-3, AF-12.0-3, AF-13.0-3, AF-13.3-3, AF-14.7-3		P6073300019KZ P6073300119KZ	B	1.771 x 9.23	<b>K120A</b>			ST70-30	92.120.01	84.122.05

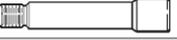
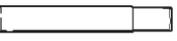
PIN TYPE CHART:			
	<b>A</b> – SINGLE LOCK FLAT		<b>E</b> – TAPERED THREADED
	<b>B</b> – DOUBLE LOCK FLAT		<b>F</b> – TAPERED
	<b>C</b> – SAME SIDE LOCK FLATS		<b>G</b> – STEP THREADED
	<b>H</b> – NO LOCK FLATS		<b>J</b> – SINGLE STEP

1. STEMCO Kaiser QwikKit® feature patented spiral steel bushings. 2. STEMCO Kaiser PlusKit® feature pre-sized steel back bronze bushings. 3. Kit has composite bushings. 4. Modify spindles to receive end plates. 5. Bolt on cap. 6. Threaded cap. 7. Length of STEMCO Kaiser pin is 9 3/4". 8. STEMCO Kaiser pin is longer than OEM. 9. Torque Spec. for king pin nut is 230 ft/lbs. 10. Torque Spec. for king pin nut is 300 ft/lbs. 11. Torque Spec. for king pin nut is 406 ft/lbs. 12. Torque Spec. for king pin nut is 350/475 ft/lbs. 13. Includes end caps. 14. Torque Spec. for knuckle attachment bolts is 170-200 ft/lbs. 15. Kit uses special removal tool ST90-1.

## FOR ALL QWIKKIT® – BUSHING "T" HANDLE WRENCHES

TOOL NO.	DESCRIPTION
ST-100-1	Short "T" Handle Wrench
ST-100-2	Long "T" Handle Wrench
100M1-1	Replacement head
Above Wrenches will fit the bushings in most kits. The Following kits do not use wrenches: K80A, K120A, K120N, K150XG, K160A, K700T, K60U, 50.121.08	

TOOL NO.	DESCRIPTION
ST-100-3	Short "T" Handle Wrench
ST-100-4	Long "T" Handle Wrench
100M1-2	Replacement head
Above Wrenches will fit the bushings in the following kits: K50F, K71F, K72F, K80G, K110G, K120G, K122V, K146E, K147E, K180E, K68Z, K69Z	

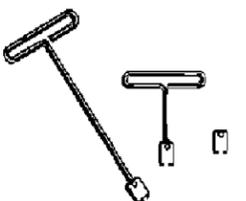

# KING PIN DIMENSIONS INTERCHANGES

DIA.	LENGTH	TYPE	MAKE	QWIKKIT	PLUSKIT	ECONO KIT
1.054	6.690	A	FORD	KE350F	75.350.06	55.350.06
1.101	7.100	A	MITSUBISHI	K60U	NA	NA
1.109	6.340	A	CHEVY	K51G		
1.179	6.360	A	CHEVY	K55G	70.055.07	50.055.07
1.179	6.360	A	CHEVY	K56G	70.056.07	50.056.07
1.179	6.360	A	WORKHORSE	K58G	70.058.07	NA
1.179	7.310	A	WORKHORSE	K50W	NA	NA
1.181	7.380	A	ISUZU	K68Z	70.068.26	NA
1.181	7.380	A	ISUZU	K69Z	70.069.26	NA
1.230	8.906	A	FORD	K70F	70.073.06	50.073.06
1.231	7.859	A	FORD	K50F	70.053.06	50.053.06
1.234	6.780	A	MERITOR	K60R	NA	NA
1.234	7.437	B	DODGE	K70D	70.070.04	50.070.04
1.234	7.660	A	IH	K98I	70.098.09	50.098.09
1.249	7.875	A	CHEVY	K70G	70.070.07	50.070.07
1.300	7.270	A	FORD	K71F	70.071.06	50.071.06
1.300	7.750	B	FORD	K72F	70.072.06	50.072.06
1.359	7.970	C	DANA	K103S	70.103.19	50.103.19
1.359	7.970	A	IH	K101I	70.101.09	50.101.09
1.359	7.970	B	IH	K102I	70.102.09	50.102.09
1.377	7.000	A	MACK	K75M	NA	NA
1.430	8.250	B	FORD	K75F	70.075.06	50.075.06
1.430	8.250	B	FORD	K76F	70.076.06	50.076.06
1.433	8.500	B	ROCKWELL	KD901R	74.901.18	54.901.18
1.434	8.750	E	CHEVY	K95G	70.095.07	50.095.07
1.484	8.850	A	IH	K108I	NA	NA
1.484	8.850	B	IH	K109I	NA	NA
1.500	7.150	B	MERITOR	K70R	70.070.18	50.070.18
1.500	7.400	F	MACK	K535M	NA	NA
1.500	7.500	B	ROCKWELL	K80R	70.080.18	50.080.18
1.500	8.930	B	WATSON CHALIN	K81W	NA	NA
1.500	8.930	B	ROCKWELL	K941R	70.941.18	50.941.18
1.606	8.812	B	ROCKWELL	K970R	70.970.18	50.970.18
1.606	9.080	B	FORD	K95F	70.095.06	50.095.06
1.606	9.080	B	FORD	K96F	70.096.06	50.096.06
1.609	9.160	A	IH	K309I	70.309.09	50.309.09
1.609	9.160	B	IH	K310I	70.310.09	50.310.09
1.609	9.380	B	ROCKWELL	K971R		
1.609	9.660	A	IH	K139I	70.139.09	50.139.09
1.609	9.660	B	IH	K140I	70.140.09	50.140.09
1.609	9.750	E	CHEVY	K125G	70.125.07	50.125.07
1.614	8.000	G	CHEVY	K80G	NA	NA
1.625	7.468	F	MACK	K533M	70.533.13	50.533.13
1.625	9.190	A	EATON	K120E	70.120.05	50.120.05
1.625	9.190	A	EATON	K121E	70.121.05	50.121.05
1.745	9.380	B	CHEVY	K121G	70.121.07	50.121.07
1.771	8.060	B	ALLIANCE	K80A	NA	NA
1.771	9.230	B	ALLIANCE	K120A	NA	NA
1.777	8.620	E	VOLVO	K122V	NA	NA
1.794	8.840	B	ROCKWELL	K132R	NA	NA
1.794	8.870	B	ROCKWELL	K981R	70.981.18	50.981.18
1.794	9.020	B	ROCKWELL	K130R	NA	NA

DIA.	LENGTH	TYPE	MAKE	QWIKKIT	PLUSKIT	ECONO KIT
1.794	9.020	B	ROCKWELL	K131R	NA	NA
1.794	9.050	A	EATON	K122E	70.122.05	50.122.05
1.794	9.050	A	LINK	K123K	NA	NA
1.794	9.050	A	LINK	K132K	NA	NA
1.794	9.180	B	ROCKWELL	K901L	70.901.12	50.901.12
1.794	9.190	B	ROCKWELL	KH946R	78.946.18	58.946.18
1.794	9.050	C	DANA	K123E	70.123.05	50.123.05
1.794	10.070	B	WATSON CHALIN	K130W	70.130.23	50.130.23
1.794	10.070	B	FORD	K941F	70.941.06	50.941.06
1.794	10.070	B	FORD	K942F	70.942.06	50.942.06
1.794	10.392	B	ROCKWELL	K120R	70.120.18	50.120.18
1.794	10.400	B	ROCKWELL	K931L	70.931.12	50.931.12
1.794	10.400	B	ROCKWELL	K961L	70.961.12	50.961.12
1.794	10.400	B	ROCKWELL	KG931R	77.931.18	57.931.18
1.794	10.390	B	ROCKWELL	K921L	70.921.12	50.921.12
1.794	10.687	E	GMC COACH	K170G	NA	NA
1.794	11.000	B	NEOPLAN	K162S	NA	NA
1.810	9.540	H	HENDRICKSON	K120H	NA	NA
1.810	9.540	A	HENDRICKSON	K131H	NA	NA
1.810	10.530	B	FORD	K146F	NA	NA
1.810	10.560	A	WESTPORT	K125W	70.125.23	70.125.23
1.810	10.560	A	WESTPORT	K126W	70.126.23	50.126.23
1.810	10.560	A	WESTPORT	K127W	70.127.23	50.127.23
1.810	10.781	A	WESTPORT	K120W	NA	NA
1.860	10.750	B	SPICER	K146S	NA	NA
1.872	8.660	C	DANA	K145E	NA	NA
1.872	9.050	C	DANA	K147E	70.147.05	70.147.05
1.872	9.050	A	EATON	K146E	70.146.05	50.146.05
1.872	9.970	A	EATON	K180E	70.180.05	50.180.05
1.889	9.200	G	CHEVY	K110G	NA	NA
1.889	9.620	G	CHEVY	K120G	NA	NA
1.921	9.875	B	IH	K120I	70.120.09	50.120.09
1.921	10.625	B	IH	K120I	70.120.09	50.120.09
1.969	8.770	J	MAN	K120N	NA	NA
1.969	9.880	E	VOLVO	K140V	NA	NA
1.999	10.790	B	ROCKWELL	K200R	NA	NA
1.999	11.040	B	ROCKWELL	KH901L	78.901.12	58.901.12
1.999	11.212	B	ROCKWELL	K180R	70.180.18	50.180.19
1.999	11.212	B	ROCKWELL	K181R	70.181.18	50.181.18
1.999	11.212	B	FORD	KH931F	78.931.06	58.931.06
1.999	11.212	B	ROCKWELL	KH931L	78.931.12	58.931.12
1.999	11.320	A	KGI	K150KG	NA	NA
2.046	10.070	B	DANA	K200S	NA	NA
2.046	10.070	C	DANA	K201S	NA	NA
2.046	10.120	B	IH / SPICER	K141S	70.141.19	50.141.19
2.046	11.000	B	DANA	K161S	NA	NA
2.046	11.000	B	SPICER	K160S	70.160.19	50.160.19
2.125	8.750	F	MACK	K616M	70.616.13	50.616.13
2.125	9.750	B	ALLIANCE	K160A	NA	NA
2.248	11.300	B	IMT / INGERSOLL	K700T	70.700.20	NA
2.249	10.600	A	KGI	K230KG	70.230.07	NA
2.441	8.920	E	MACK	K536M	NA	NA

# KING PIN SUPPORT INFORMATION AND PRODUCTS

## SPINDLE BORE AND AXLE BORE SIZES

KAISER DESIGN	SPINDLE BORE SIZE	AXLE BORE SIZES
K101I	1.483/1.485	1.358/1.360
K102I	1.483/1.485	1.358/1.360
K103S	1.483/1.485	1.358/1.360
K108I	1.608/1.610	1.485/1.487
K109I	1.608/1.610	1.485/1.487
K110G	2.047/2.049	1.891/1.893
K120A	2.045/2.047	1.772/1.774
K120E	1.749/1.750	1.626/1.627
K120G	2.047/2.049	1.891/1.893
K120H	1.937/1.939	
K120I	2.045/2.047	1.922/1.923
K120N	2.283/2.284	1.967/1.968
K120R	1.919/1.921	1.795/1.797
K120W	1.937/1.939	1.811/1.812
K121E	1.749/1.750	1.626/1.627
K121G	1.876/1.878	1.745/1.747
K122E	1.919/1.921	1.794/1.796
K122V	1.969/1.971	Tapered
K123E	1.919/1.921	1.794/1.796
K123K	1.919/1.921	1.794/1.796
K125G	1.733/1.735	Tapered
K125W	1.937/1.939	1.811/1.812
K126W	1.936/1.938	1.811/1.812
K127W	1.936/1.938	1.811/1.812
K130R	1.919/1.921	1.795/1.797
K130W	1.919/1.921	1.795/1.797
K131H	1.937/1.939	1.811/1.812
K131R	1.919/1.921	1.795/1.797
K132K	1.919/1.921	1.794/1.796
K132R	1.919/1.921	1.795/1.797
K139I	1.733/1.735	1.610/1.612
K140I	1.733/1.735	1.610/1.612
K140V	2.164/2.166	TAPERED
K141S	2.171/2.173	2.047/2.048
K145E	2.057/2.058	1.873/1.875
K146E	2.057/2.058	1.873/1.875

KAISER DESIGN	SPINDLE BORE SIZE	AXLE BORE SIZES
K146F	1.936/1.938	1.811/1.812
K146S	1.994/1.996	1.862/1.864
K147E	2.057/2.058	1.873/1.875
K149E	2.057/2.058	1.873/1.875
K150KG	2.373/2.374	2.000/2.002
K160A	2.440/2.442	2.126/2.128
K160S	2.171/2.173	2.047/2.048
K161S	2.171/2.173	2.047/2.048
K162S	1.919/1.921	1.794/1.796
K170G	1.919/1.921	Tapered
K180E	2.057/2.058	1.873/1.875
K180R	2.124/2.126	2.000/2.002
K181R	2.124/2.126	2.000/2.002
K200R	2.124/2.126	2.000/2.002
K200S	2.171/2.172	2.047/2.048
K201S	2.171/2.172	2.047/2.048
K230KG	2.624/2.626	2.250/2.252
K309I	1.733/1.735	1.610/1.612
K310I	1.733/1.735	1.610/1.612
K50F	1.375/1.377	1.232/1.234
K50W	1.314/1.316	1.180/1.182
K51G	1.229/1.231	1.110/1.112
K533M	1.749/1.751	Tapered
K535M	1.624/1.626	Tapered
K536M	2.559/2.561	Tapered
K55G	1.298/1.300	1.180/1.182
K56G	1.314/1.316	1.180/1.182
K58G	1.314/1.316	1.180/1.182
K60R	1.358/1.360	1.235/1.237
K60U	1.337/1.339	1.102/1.104
K616M	2.499/2.501	Tapered
K68Z	1.338/1.340	1.182/1.184
K69Z	1.338/1.340	1.182/1.184
K700T	2.499/2.501	2.250/2.252
K70D	1.358/1.360	1.235/1.237
K70F	1.355/1.357	1.232/1.234

KAISER DESIGN	SPINDLE BORE SIZE	AXLE BORE SIZES
K70G	1.368/1.370	1.250/1.252
K70R	1.626/1.628	1.501/1.503
K71D	1.358/1.360	1.235/1.237
K71F	1.460/1.462	1.301/1.303
K72F	1.454/1.456	1.301/1.303
K75F	1.560/1.562	1.433/1.435
K75M	1.652/1.654	1.378/1.380
K76F	1.560/1.562	1.433/1.435
K80A	2.045/2.047	1.772/1.774
K80G	1.771/1.773	1.615/1.617
K80R	1.626/1.628	1.501/1.503
K81W	1.626/1.628	1.501/1.503
K901L	1.919/1.921	1.795/1.797
K921L	1.919/1.921	1.795/1.797
K931L	1.919/1.921	1.795/1.797
K941F	1.919/1.921	1.795/1.797
K941FA	1.919/1.921	1.795/1.797
K941R	1.626/1.628	1.501/1.503
K942F	1.919/1.921	1.795/1.797
K942FA	1.919/1.921	1.795/1.797
K95F	1.733/1.735	1.607/1.609
K95G	1.560/1.562	Tapered
K961L	1.919/1.921	1.795/1.797
K96F	1.733/1.735	1.607/1.609
K970R	1.733/1.735	1.608/1.610
K971R	1.733/1.735	1.608/1.610
K981R	1.920/1.921	1.795/1.797
K98I	1.358/1.360	1.235/1.237
KD901R	1.560/1.562	1.434/1.436
KE350F	1.179/1.181	1.055/1.057
KG931R		

# KING PIN SUPPORT INFORMATION AND PRODUCTS

## PLUSKIT® KING PIN BUSHING DRIVERS

PLUSKIT NO.	DRIVER NO.	PLUSKIT NO.	DRIVER NO.	PLUSKIT NO.	DRIVER NO.	PLUSKIT NO.	DRIVER NO.
70.053.06	ST70-3	70.073.06	ST70-3	70.123.05	ST70-7	70.616.13	ST70-18
70.055.07	ST70-4	70.075.06	ST70-9	70.125.07	ST70-5	70.700.20	ST70-29
70.056.07	ST70-4	70.076.06	ST70-9	70.125.23	ST70-33	70.901.12	ST70-7
70.058.07	ST70-4	70.080.18	ST70-28	70.126.23	ST70-33	70.921.12	ST70-7
70.068.26	ST70-37	70.095.06	ST70-13	70.127.23	ST70-33	70.931.12	ST70-7
70.069.26	ST70-37	70.095.07	ST70-9	70.130.23	ST70-7	70.941.06	ST70-7
70.070.07	ST70-1	70.096.06	ST70-13	70.139.09	ST70-5	70.941.18	ST70-28
70.070.18	ST70-28	70.098.09	ST70-10	70.140.09	ST70-5	70.942.06	ST70-7
70.071.04	ST70-10	70.101.09	ST70-2	70.141.19	ST70-24	70.961.12	ST70-7
70.071.06	ST70-17	70.102.09	ST70-2	70.146.05	ST70-23	70.970.18	ST70-13
70.072.06	ST70-17	70.103.19	ST70-2	70.147.05	ST70-23	70.981.18	ST70-7
		70.120.05	ST70-6	70.160.19	ST70-24	74.901.18	ST70-9
		70.120.09	ST70-19	70.180.05	ST70-23	74.931.18	ST70-13
		70.120.18	ST70-7	70.180.18	ST70-12	75.350.06	ST70-15
		70.120.99	ST70-19	70.181.18	ST70-12	77.931.18	ST70-7
		70.121.05	ST70-6	70.230.07	ST70-29	78.901.12	ST70-12
		70.121.07	ST70-11	70.309.09	ST70-5	78.931.06	ST70-12
		70.122.05	ST70-7	70.310.09	ST70-5	78.931.12	ST70-12
		70.122.95	ST70-7	70.533.13	ST70-6	78.946.18	ST70-7

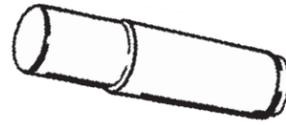

## “NO GO” GAUGE KIT

STK81 CONTAINS: ST81-1, ST81-2, ST81-3, ST81-4, ST81-5, ST81-6					
“NO GO” GAUGE TOOLS					
NO-GO	QWIKKIT	PLUSKIT	NO-GO	QWIKKIT	PLUSKIT
ST81-1	K981R*	70.981.18	ST81-2	K56G	70.056.07
ST81-1	K122E*	70.122.05	ST81-2	K58G	70.058.07
ST81-1	K123K	NA	ST81-2	K50W	NA
ST81-1	K132K	NA	ST81-3	K103S	70.103.19
ST81-1	K901L	70.901.12	ST81-3	K101I	70.101.09
ST81-1	KH946R*	78.946.18	ST81-3	K102I	70.102.09
ST81-1	K123E*	70.123.05	ST81-4	K120E	70.120.05
ST81-1	K941F	70.941.06	ST81-4	K121E	70.121.05
ST81-1	K942F	70.942.06	ST81-5	K147E	70.147.05
ST81-1	K120R	70.120.18	ST81-5	K146E	70.146.05
ST81-1	K931L*	70.931.12	ST81-5	K180E	70.180.05
ST81-1	K961L*	70.961.12	ST81-6	KH901L	78.901.12
ST81-1	KG931R	77.931.18	ST81-6	K180R	70.180.18
ST81-1	K921L	70.921.12	ST81-6	K181R	70.181.18
ST81-1	K162S	NA	ST81-6	KH931L	78.931.12
ST81-2	K55G	70.055.07	ST81-6	K150KG	NA

## PART NUMBERS BELOW REQUIRE SPECIAL BUSHING DRIVER

KIT NO.	TOOL NO.	KIT NO.	TOOL NO.
K75M	ST70-25	K160A	ST70-31
K80A	ST70-30	K230KG	ST70-29
K120A	ST70-30	K700T	ST70-29
K120N	ST70-27	K60U	ST70-34
K150KG	ST70-26	50.121.08	ST70-32

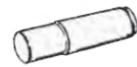

# FRONT SPRING PINS AND BUSHINGS

MODEL	PIN TYPE	PIN		BUSHING		LOCATION			SPRING PRODUCTS				
		SIZE	LOCK	SIZE	SRI	OEM PIN NO.	F*	R*	H*	PIN NO.	QWIK BUSHING NO.	LUBRAFLEX™ BUSHING NO.	GENERIC BUSHING NO.
<b>ADVANCE MIXER</b>													
		1.25" x 7.70"		1.50" x 3.50"	RNI		X	X	X	BSP73-1	BSA120-5		
<b>BLUEBIRD</b>													
TC2000 All American Pre-1998		1.12" x 5.00"	.61"‡	1.37" x 3.00"	PLG		X	X		BSP25-2	BSA110-2		
		1.12" x 5.00"	.61"‡	1.37" x 4.00"	PLK	0997056			X		BSP25-2	BSA110-7	
TC2000 & All American 1994 - Present		1.25" x 6.25"	5.08"	1.50" x 4.00"	RNK	1662774 00051758	X	X	X	BSP12-17	BSA120-9	BSL120-9	BSG120-9
<b>CRANE CARRIER</b>													
Centurion Series		1.25" x 6.50"	.625"	1.50" x 4.00"	RNK	243-235	X			BSP37-2	BSA120-9	BSL120-9	BSG120-9
		1.25" x 6.12"	5.00"	1.50" x 4.00"	RNK	243-233		X	X		BSP12-12	BSA120-9	BSL120-9
<b>FORD</b>													
F, FT, L, LN, LT, LNT, LST, LS, W, WT, H, HT, N, NT, 600 thru 1100		1.00" x 5.81"	4.84"	1.25" x 4.00"	NJK	DOHZ-5780F C7TZ-5348LC D1HA-5A314-AA ESHZ-5780A EBHT-5A314-AA ESHZ-5780A	X	X	X	BSP10-7	BSA100-2		BSG100-2
Louisville with cast front hangers		1.00" x 6.42"	5.16"	1.25" x 4.00"	NJK	DOHA-5A314-C DOHZ-5780E ESHZ-5780B	X			BSP10-8	BSA100-2		BSG100-2
COE C Series BLUEBIRD TC2000		1.00" x 5.12"		1.25" x 3.00"	NJG	G6TZ-5304B		X	X	BSP64-2	BSA100-4		
COE C Series		1.00" x 5.01"		1.25" x 3.00"	NJG	B7TZ-5465B B7A-5465A B7Q-5465A D5HZ-5465A		X	X	BSP18-5	BSA100-4		
<b>FREIGHTLINER</b>													
4 spring eyes strap style shackles		1.25" x 6.88"	5.37"	1.50" x 4.00"	RNK	16-12373-000 16-13470-000 16-13078-000	X	X	X	BSP38-2	BSA120-9	BSL120-9	BSG120-9
		1.25" x 7.12"	5.37"				16-12302-000	X	X	X	BSP79-1**		
4 spring eyes strap style shackles		1.25" x 6.88"	5.37"	1.62" x 4.00"	TNK	16-12373-000 16-13470-000 16-13078-000 16-13079-000			X	BSP38-2	BSA120-10	BSL120-10	
<b>GILLIG</b>													
All Models		1.37" x 7.00"				55-00696-001	X	X	X	BSP78-1**			
<b>HME</b>													
		1.00" x 6.68"									BSP53-1		

\* F = Spring front eye, R = Spring rear eye, H = Hanger, \*\*Threaded pin  
‡From opposite grease fitting end, †From grease fitting end, SRI = Spring Research Institute

# FRONT SPRING PINS AND BUSHINGS

MODEL	PIN			BUSHING			LOCATION			SPRING PRODUCTS			
	PIN TYPE	SIZE	LOCK	SIZE	SRI	OEM PIN NO.	F*	R*	H*	PIN NO.	QWIK BUSHING NO.	LUBRAFLEX™ BUSHING NO.	GENERIC BUSHING NO.
<b>INTERNATIONAL / NAVISTAR</b>													
All 4000,5000 Series Hd. dia. grease fitting end 1.497; opp. end 1.062		1.37" x 7.37"	5.75"	1.765" x 4.00"		688953-R1	X			BSP67-1**			BSG60026-1
Hd. dia. each end 1.062		1.25" x 7.06"	5.75"	1.75" x 4.00"	VNK	688952-R1		X	X	BSP20-2	BSA120-2		
		1.37" x 7.37"	5.75"	1.765" x 4.00"		688952-R1		X	X	BSP68-1**			BSG60026-1
All S models with 4 springs 1600,1700,1800 1900,2200,2400 2500,2600 Series		1.00" x 7.00"	.96"†	1.25" x 4.00"	NJK	1648109C1 468703C2	X			BSP34-1	BSA100-2		BSG100-2
		1.00" x 6.31"	4.92"	1.25" x 4.00"	NJK	468704C1 1648110C1		X	X	BSP35-1	BSA100-2		BSG100-2
All 9000 Series		1.00" x 7.25"	5.75"	1.75" x 4.00"	VJK		X	X	X	BSP41-1			
9000 Series COE & Conv.		1.37" x 7.37"	5.75"	1.75" x 4.00"		507203C1	X	X	X	BSP71-1**			BSG5295-1
S Models with 10,000# axle & heavier 2000,3000,3800, 4000, Series		1.25" x 6.50"	5.03"	1.50" x 4.00"	RNK	1661976C3 3511254C1	X	X	X	BSP49-1	BSA120-9	BSL120-9	BSG120-9
<b>KENWORTH</b>													
Grease fitting port on large end of pin		1.37" x 7.37"	5.75"	1.75" x 4.00"		6262	X			BSP67-1**			BSG5295-1
Grease fitting port on small end of pin		1.37" x 7.37"	5.75"	1.75" x 4.00"		K179-378	X			BSP69-1**			BSG5295-1
		1.37" x 7.37"	5.75"	1.75" x 4.00"		5296		X	X	BSP70-1**			BSG5295-1
<b>KME</b>													
		1.00" x 5.87"	4.53"	1.25" x 3.50"	NJI	023658F		X	X	BSP82-1		BSL100-7	
<b>MACK</b>													
		1.25" x 6.25"	.68"‡	1.50" x 3.50"	RNI	44QK173B	X			BSP31-6	BSA120-5		
		1.31" x 7.03"	5.59"	1.77" x 4.00"		10QK3105M				BSP85-1**			BSG0078-1
		1.37" x 6.66"	5.01"	1.75" x 3.50"		44QK26A		X	X	BSP90-1**			BSG0069-1
<b>OSHKOSH</b>													
S Series Front Discharge Mixer 1994-		1.12" x 6.25"	4.63"	1.37" x 3.00"	PLG	2044870	X			BSP58-1	BSA110-6		
		1.12" x 4.95"	.19"‡	1.37" x 3.00"	PLG	57613BX		X		BSP75-1	BSA110-6		
Snowplow		1.12" x 6.25"	.44"†	1.37" x 3.00"	PLG	1664070	X			BSP74-1	BSA110-6		
Snowplow		1.12" x 4.95"	.19"‡	1.37" x 3.00"	PLG	57613BX		X		BSP75-1	BSA110-6		
		1.12" x 4.95"	.19"‡	1.50" x 3.00"	RLG	57613BX			X	BSP75-1	BSA110-8		
P19A FIRE APPARATUS		1.12" x 5.50"	.19"‡		RLG	1416710			X	BSP75-2	BSA110-8		
		1.25" x 6.12"	.19"‡		RNK	107487B	X			BSP75-3	BSA110-8		
		1.25" x 6.62"	.19"†	1.50" x 4.00"	RNK	1418150		X		BSP98-1	BSA120-9		

\* F = Spring front eye, R = Spring rear eye, H = Hanger, \*\*Threaded pin  
†From opposite grease fitting end, ‡From grease fitting end, SRI = Spring Research Institute

MODEL	PIN			BUSHING			LOCATION			SPRING PRODUCTS			
	PIN TYPE	SIZE	LOCK	SIZE	SRI	OEM PIN NO.	F*	R*	H*	PIN NO.	QWIK BUSHING NO.	LUBRAFLEX™ BUSHING NO.	GENERIC BUSHING NO.
<b>PIERCE</b>													
		1.12" x 7.00"	5.48"	1.37" x 4.00"	PLK	1006385 40-6954 40-9533 2267668	X	X	X	BSP24-2	BSA110-4	BSL110-4	BSG110-4
		1.25" x 6.50"	5.03"	1.50" x 4.00"	RNK	1006386 2267670 40-8553 40-9534	X	X	X	BSP49-1	BSA120-9	BSL120-9	BSG120-9
		1.25" x 5.56"	4.00"	1.50" x 3.00"	RNG	1006387 40-4958 40-9535 2267672		X	X	BSP55-1	BSA120-6	BSL120-6	BSG120-6
		1.12" x 5.50"	0.62"‡	1.37" x 3.00"	PLG	1006382 40-0195 40-9531 2267673				BSP65-1	BSA110-6		
		1.12" x 5.13"	0.62"‡	1.37" x 3.00"	PLG	1006383 40-6745 40-9532 2267676				BSP65-2	BSA110-6		
		1.00" x 5.59"	4.56"	1.25" x 3.50"	NJI	1006380 40-0190 40-9529 2267678				BSP66-1		BSL100-7	
		1.00" x 6.00"	4.75"	1.25" x 3.50"	NJI	1006381 40-6006 40-9530 2267679				BSP66-2		BSL100-7	
<b>PETERBILT</b>													
359 Conv. 352 COE		1.25" x 6.12"	5.00"	1.50" x 3.50"	RNI	02-01560 02-00180 02-01846	X			BSP12-12	BSA120-5		
		1.25" x 5.56"	4.37"	1.50" x 3.50"	RNI	02-00082 02-01847		X	X	BSP12-13	BSA120-5		
Cab Over Model 362		1.25" x 6.25"	5.08"	1.50" x 4.00"	RNK	02-01561	X	X	X	BSP12-17	BSA120-9	BSL120-9	BSG120-9
Conventional Model 359		1.25" x 5.62"	4.50"	1.50" x 3.00"	RNG	02-01562			X	BSP12-18	BSA120-6	BSL120-6	BSG120-6
Cab Over Model 362		1.25" x 6.25"	5.08"	1.50" x 3.50"	RNI	02-01561			X	BSP12-17	BSA120-5		
Conventional Models 357, 362, 379 1986 with Airide		1.25" x 6.85"	5.31"	1.50" x 4.00"	RNK	02-1767 02-1781	X	X	X	BSP50-1	BSA120-9	BSL120-9	BSG120-9
<b>ROSENBAUER</b>													
		1.25" x 6.88"	5.37"							BSP39-1			
<b>STERLING</b>													
		1.25" x 6.66"	5.12"	1.50" x 4.00"	RNK	F7HZ-5780DB	X	X	X	BSP50-2	BSA120-9	BSL120-9	BSG120-9
<b>SUTPHEN FIRE CHASSIS</b>													
		1.00" x 4.63"		1.25" x 3.00"	NJG			X	X	BSP64-2 Shackle kit KT000F-9	BSA100-4		
		1.00" x 5.01"		1.25" x 3.00"	NJG		X			BSP18-5	BSA100-4		

\* F = Spring front eye, R = Spring rear eye, H = Hanger, \*\*Threaded pin  
†From opposite grease fitting end, ‡From grease fitting end, SRI = Spring Research Institute

# REAR SPRING PINS AND BUSHINGS

MODEL	PIN			BUSHING			LOCATION			SPRING PRODUCTS			
	PIN TYPE	SIZE	LOCK	SIZE	SRI	OEM PIN NO.	F*	R*	H*	PIN NO.	QWIK BUSHING NO.	LUBRAFLEX™ BUSHING NO.	GENERIC BUSHING NO.
<b>THOMAS</b>													
MODEL ER 1994 - Present		1.12" x 7.00"	5.48"	1.37" x 4.00"	PLK	62300122				BSP24-2	BSA110-3		
<b>VOLVO / GMC</b>													
AERO Model w/German Springs		1.12" x 7.00"	5.48"	1.37" x 4.00"	PLK	37121-0001 3082276 3974787	X	X		BSP24-2		BSL110-4	BSG110-4
		1.12" x 7.00"	5.48"	1.37" x 4.00"	PLK	37121-0001 3082276 3974787			X	BSP24-2	BSA110-3 Bushings O.D. 1.3770	BSL110-4	BSG110-4
1989 - Present w/Hendrickson Springs		1.12" x 7.00"	5.48"	1.37" x 4.00"	PLK	37121-0001 3082276 3974788	X	X		BSP24-2	BSA110-1 Bushings O.D. 1.3735	BSL110-4	BSG110-4
1989 - Present w/Hendrickson Springs		1.12" x 7.00"	5.48"	1.37" x 4.00"	PLK	37121-0001 3082276 3974787			X	BSP24-2	BSA110-3 Bushings O.D. 1.3770	BSL110-4	BSG110-4
Models N10, N12 Grease fitting port on large end of pin		1.31" x 7.03"	5.59"	1.77" x 4.12"		1614230 1075723	X	X	X	BSP83-1			BSG0078-1
Grease fitting port on small end of pin		1.31" x 7.03"	5.59"	1.77" x 4.12"		1614229 1076334	X	X	X	BSP85-1			BSG0078-1
<b>WESTERN STAR</b>													
F3W-125, F6W-1200 RB-2, RC-2		1.12" x 7.00"	5.48"	1.37" x 4.00"	PLK	37121-0001	X	X	X	BSP24-2	BSA110-1		
		1.12" x 5.95"	5.03"	1.37" x 4.00"	PLK	37121-3413		X	X	BSP63-1	BSA110-1		
		1.12" x 6.90"	5.63"	1.37" x 4.00"	PLK	37121-3412	X			BSP63-2	BSA110-1		
<b>WHITE</b>													
F3W-120 12000#		1.00" x 6.25"	.51"†	1.25" x 4.00"	NIJ	506267	X	X		BSP10-6	BSA101-1		

## S.R.I. NUMBERING SYSTEM

### S.R.I. SPRING RESEARCH INSTITUTE STANDARDIZED NUMBERING SYSTEM FOR SPRING EYE BUSHINGS

1ST LETTER REPRESENTING O.D. "J" is 1" ± each letter is 1/16" - "K" = 1 1/16" - "L" = 15/16"

2ND LETTER REPRESENTS I.D. "J" is 1" ± each letter is 1/16" - "K" = 1 1/16" - "L" = 15/16"

3RD LETTER REPRESENTS LENGTH "K" is 4" ± each letter is 1/4" = "J" is 3 3/4" - "L" is 4 1/4"

In addition, bushing material may be indicated with a two or three letter suffix. For example: SB = Steel Backed Bronze.

DIMENSION	— INCREMENTS	BASE LETTER	+ INCREMENTS
O.D.	1/16"	J=1"	1/16"
I.D.	1/16"	J=1"	1/16"
LENGTH	1/4"	K=4"	1/4"

\* F = Spring front eye, R = Spring rear eye, H = Hanger, \*\*Threaded pin  
†From opposite grease fitting end, ‡From grease fitting end, SRI = Spring Research Institute

MODEL	PIN			BUSHING			LOCATION			SPRING PRODUCTS			
	PIN TYPE	SIZE	LOCK	SIZE	SRI	OEM PIN NO.	F*	R*	H*	PIN NO.	QWIK BUSHING NO.	LUBRAFLEX™ BUSHING NO.	GENERIC BUSHING NO.
<b>BLUEBIRD</b>													
TC2000 Thru 1996		1.25" x 5.56"	4.00"	1.50" x 3.00"	RNG	1353440	X			BSP55-1	BSA120-6	BSL120-6	BSG120-6
All American Rear engine		1.25" x 6.00"	.59"‡	1.50" x 4.00"	RNK	1034271	X	X	X	BSP60-1	BSA120-13		
<b>FORD</b>													
COE C Series		1.12" x 5.00"	.61"‡	1.37" x 3.00"	PLG	7E05780 B7Q5780A	X	X		BSP25-2	BSA110-2		
COE C Series		1.12" x 5.00"	.61"‡	1.25" x 2.75"	NLF				X	BSP25-2			
LN 600, 700, 750, 800, L 800, 900, F 700, 750, 800, 850, 900, 950, 1000, 1100, CL 900, H 1000, W 900, 1000,		1.25" x 5.00"	4.00"	1.50" x 3.00"	RNG	C3TZ-5780A DOHZ-5780B	X			BSP12-20	BSA120-6	BSL120-6	BSG120-6
<b>FREIGHTLINER</b>													
		1.37" x 6.00"	4.21"	1.62" x 3.00"	TPG	6803250074	X			BSP50-3		BSL13-2	
<b>HENDRICKSON REAR SUSPENSION</b>													
340 Series		1.25" x 7.18"	.62"‡	1.50" x 4.00"	RNK	BE-4927 32276		X		BSP16-2	BSA120-9	BSL120-9	BSG120-9
380/440/450 Series		1.37" x 7.12"	.62"‡	1.62" x 4.00"	TPK	BE-13938 32277		X		BSP2-2	BSA13-1	BSL13-1	BSG13-1
380/440/450 Series		1.37" x 6.9"	5.37" Double Lock	1.62" x 4.00"	TPK	43146		X		BSP46-2	BSA13-1	BSL13-1	BSG13-1
<b>INTERNATIONAL / NAVISTAR</b>													
S-SERIES		1.25" x 5.56"	4.00"	1.50" x 3.00"	RNG	1671766C1	X			BSP55-1	BSA120-6	BSL120-6	BSG120-6
<b>MACK</b>													
F&MH		1.25" x 5.62"	4.12"	1.50" x 3.00"	RNG	44QK143CP2	X			BSP59-1	BSA120-6	BSL120-6	BSG120-6

## SPRING EYE SERVICE TOOLS – SPRING PRODUCT SUPPORT ITEMS

	PART NO.	APPLICATION		PART NO.	APPLICATION
	ST-1000-1	(Fits all 1" pins)		ST-1000-5	(Fits all 1" pins)
	ST-1125-1	(Fits all 1 1/8" pins)		ST-1125-5	(Fits all 1 1/8" pins)
	ST-1250-1	(Fits all 1 1/4" pins)		ST-1250-5	(Fits all 1 1/4" pins)
	ST-1375-1	(Fits all 1 3/8" pins)		ST-1375-5	(Fits all 1 3/8" pins)
	ST-1000-6	(Fits all 1" pins)		ST-50-9	general
	ST-1125-6	(Fits all 1 1/8" pins)			
	ST-1250-6	(Fits all 1 1/4" pins)			
	ST-1375-6	(Fits all 1 3/8" pins)			

\* F = Spring front eye, R = Spring rear eye, H = Hanger, \*\*Threaded pin  
†From opposite grease fitting end, ‡From grease fitting end, SRI = Spring Research Institute

# KING PIN KIT INTERCHANGE

PART NO.	QWIKKIT	PLUSKIT	ECONO KIT
<b>ALLIANCE AXLE</b>			
P6073300019KZ	<b>K120A</b>		
P6073300119KZ	<b>K120A</b>		
P6073300219KZ	<b>K80A</b>		
P6073300319KZ	<b>K80A</b>		
P6073300419KZ	<b>K160A</b>		
P6073300519KZ	<b>K160A</b>		

PART NO.	QWIKKIT	PLUSKIT	ECONO KIT
<b>AUTOCAR</b>			
836687	<b>K125G</b>	70.125.07	50.125.07
857328	<b>K125G</b>	70.125.07	50.125.07
859552	<b>K970R</b>	70.970.18	50.970.18
1715447	<b>K970R</b>	70.970.18	50.970.18
1739844	<b>KH901L</b>	78.901.12	58.901.12
02-7091941	<b>K921L</b>	70.921.12	50.921.12

PART NO.	QWIKKIT	PLUSKIT	ECONO KIT
<b>AUTOMANN</b>			
460.102B	<b>K70G</b>	70.070.07	50.070.07
460.105B	<b>K68Z</b>	70.068.26	
460.106B	<b>K69Z</b>	70.069.26	
460.122B	<b>K970R</b>	70.970.18	50.970.18
460.148B	<b>K921L</b>	70.921.12	50.921.12
460.160B	<b>K140I</b>	70.140.09	50.140.09
460.162B	<b>K75F</b>	70.075.06	50.075.06
460.164B	<b>K55G</b>	70.055.07	50.055.07
460.166B	<b>KH931L</b>	78.931.12	58.931.12
460.168B	<b>K941F</b>	70.941.06	50.941.06
460.172B	<b>KE350F</b>	75.350.06	55.350.06
460.186B	<b>KE350F</b>	75.350.06	55.350.06
460.194B	<b>K533M</b>	70.533.13	50.533.13
460.196B	<b>K121G</b>	70.121.07	50.121.07
460.200B	<b>K126W</b>	70.126.23	50.126.23
460.204B	<b>K931L</b>	70.931.12	50.931.12
460.206B	<b>K310I</b>	70.310.09	50.310.09
460.207B	<b>K700T</b>	70.700.20	
460.212B	<b>K616M</b>	70.616.13	50.616.13
460.216B	<b>K140I</b>	70.140.09	50.140.09
460.220C	<b>K120E</b>	70.120.05	50.120.05
460.244B	<b>K102I</b>	70.102.09	50.102.09
460.246B	<b>K961L</b>	70.961.12	50.961.12
460.254B	<b>K120E</b>	70.120.05	50.120.05
460.255N	<b>K122V</b>		
460.260B	<b>K120I</b>	70.120.09	50.120.09
460.260C	<b>K120I</b>	70.120.09	50.120.09
460.262B	<b>K141S</b>	70.141.19	50.141.19
460.264B	<b>K76F</b>	70.076.06	50.076.06
460.266B	<b>K80G</b>		
460.286B	<b>K122E</b>	70.122.05	50.122.05
460.480B	<b>K56G</b>	70.056.07	50.056.07
460.512C	<b>K146E</b>	70.146.05	50.146.05
460.518C	<b>K981R</b>	70.981.18	50.981.18
460.534B	<b>K147E</b>	70.147.05	50.147.05
460.536C	<b>K103S</b>	70.103.19	50.103.19

PART NO.	QWIKKIT	PLUSKIT	ECONO KIT
<b>BLUEBIRD</b>			
00063311			50.121.08
00063312			50.121.08
00063313			50.121.08
2137305	<b>K931L</b>	70.931.12	50.931.12
2156784	<b>K140I</b>	70.140.09	50.140.09
2599033	<b>K931L</b>	70.931.12	50.931.12
4279568	<b>KG931R</b>	77.931.18	57.931.18
4280855	<b>K961L</b>	70.961.12	50.961.12
4293270	<b>K140I</b>	70.140.09	50.140.09
4294716	<b>K146S</b>		
8305203	<b>K120I</b>	70.120.09	50.120.09
8305211	<b>K141S</b>	70.141.19	50.141.19
8314171	<b>K102I</b>	70.102.09	50.102.09

PART NO.	QWIKKIT	PLUSKIT	ECONO KIT
<b>BWP</b>			
M-2300	<b>K51G</b>		
M-2301	<b>K981</b>	70.098.09	50.098.09
M-2305	<b>K125G</b>	70.125.07	50.125.07
M-2306	<b>K95G</b>	70.095.07	50.095.07
M-2309	<b>K125G</b>	70.125.07	50.125.07
M-2310	<b>K50F</b>	70.053.06	50.053.06
M-2311	<b>KD901R</b>	74.901.18	54.901.18
M-2312	<b>KD901R</b>	74.901.18	54.901.18
M-2313	<b>K95G</b>	70.095.07	50.095.07
M-2315	<b>K901L</b>	70.901.12	50.901.12
M-2316	<b>K70G</b>	70.070.07	50.070.07
M-2317	<b>K70G</b>	70.070.07	50.070.07
M-2318	<b>K51G</b>		
M-2319	<b>K51G</b>		
M-2320	<b>K70F</b>	70.073.06	50.073.06
M-2321	<b>K70F</b>	70.073.06	50.073.06
M-2322	<b>K901L</b>	70.901.12	50.901.12
M-2325	<b>K109I</b>		50.109.09
M-2326	<b>K970R</b>	70.970.18	50.970.18
M-2327	<b>K970R</b>	70.970.18	50.970.18
M-2331	<b>K921L</b>	70.921.12	50.921.12
M-2332	<b>K140I</b>	70.140.09	50.140.09
M-2333	<b>K140I</b>	70.140.09	50.140.09
M-2334	<b>K75F</b>	70.075.06	50.075.06
M-2335	<b>K55G</b>	70.055.07	50.055.07
M-2336	<b>KH901L</b>	78.901.12	58.901.12
M-2337	<b>KE350F</b>	75.350.06	55.350.06
M-2338	<b>K95F</b>	70.095.06	
M-2339	<b>KH931L</b>	78.931.12	58.931.12
M-2340	<b>K941F</b>	70.941.06	50.941.06
M-2341	<b>K101I</b>	70.101.09	50.101.09
M-2342	<b>K108I</b>		50.108.09
M-2343	<b>K139I</b>	70.139.09	50.139.09
M-2344	<b>K139I</b>	70.139.09	50.139.09
M-2345	<b>K309I</b>	70.309.09	50.309.09
M-2347	<b>K533M</b>	70.533.13	50.533.13
M-2348	<b>K931L</b>	70.931.12	50.931.12
M-2349	<b>K126W</b>	70.126.23	50.126.23
M-2350	<b>K121G</b>	70.121.07	50.121.07
M-2351	<b>K120W</b>		
M-2352	<b>KH901L</b>	78.901.12	58.901.12
M-2353	<b>K535M</b>		
M-2358	<b>K971R</b>		
M-2363	<b>K70D</b>	70.070.04	50.070.04
M-2370	<b>K55G</b>	70.055.07	50.055.07
M-2373	<b>K309I</b>	70.309.09	50.309.09
M-2375	<b>KE350F</b>	75.350.06	55.350.06
M-2378	<b>K125W</b>	70.125.23	50.125.23
M-2379	<b>K310I</b>	70.310.09	50.310.09
M-2380	<b>K140I</b>	70.140.09	50.140.09
M-2381	<b>K931L</b>	70.931.12	50.931.12
M-2382	<b>K120E</b>	70.120.05	50.120.05
M-2383	<b>K121E</b>	70.121.05	50.121.05
M-2384	<b>K102I</b>	70.102.09	50.102.09
M-2385	<b>K961L</b>	70.961.12	50.961.12
M-2386	<b>K109I</b>		50.109.09
M-2387	<b>K140I</b>	70.140.09	50.140.09
M-2388	<b>K51G</b>		
M-2389	<b>K120E</b>	70.120.05	50.120.05
M-2390	<b>K121E</b>	70.121.05	50.121.05
M-2391	<b>K56G</b>	70.056.07	50.056.07
M-2392	<b>K72F</b>	70.072.06	50.072.06
M-2397	<b>K122E</b>	70.122.05	50.122.05

PART NO.	QWIKKIT	PLUSKIT	ECONO KIT
<b>CHEVROLET / GMC</b>			
722166	<b>K55G</b>	70.055.07	50.055.07
859552	<b>K901L</b>	70.901.12	50.901.12
1561960	<b>K80G</b>		
1561961	<b>K110G</b>		
1561962	<b>K120G</b>		
2010021	<b>K931L</b>	70.931.12	50.931.12
2036352	<b>KH931L</b>	78.931.12	58.931.12
2224495	<b>K51G</b>		
2254366	<b>K170G</b>		
2264897	<b>K125G</b>	70.125.07	50.125.07
2321013	<b>K95G</b>	70.095.07	50.095.07
2362900	<b>K125G</b>	70.125.07	50.125.07
2431372	<b>K95G</b>	70.095.07	50.095.07
2442145	<b>K970R</b>	70.970.18	50.970.18
2452865	<b>KH901L</b>	78.901.12	58.901.12
2470621	<b>K70D</b>	70.070.04	50.070.04
2927942	<b>K51G</b>		
3691111	<b>K51G</b>		
3745285	<b>KD901R</b>	74.901.18	54.901.18
3829410	<b>K51G</b>		
3829970	<b>K70G</b>	70.070.07	50.070.07
3838390	<b>K70G</b>	70.070.07	50.070.07
3853990	<b>K51G</b>		
3853994	<b>K70G</b>	70.070.07	50.070.07
3854744	<b>K51G</b>		
3858389	<b>K51G</b>		
3858390	<b>K70G</b>	70.070.07	50.070.07
3927942	<b>K51G</b>		
3927943	<b>K70G</b>	70.070.07	50.070.07
8885021	<b>K95G</b>	70.095.07	50.095.07
8885621	<b>K121G</b>	70.121.07	50.121.07
8885856	<b>K121G</b>	70.121.07	50.121.07
8885857	<b>K70G</b>	70.070.07	50.070.07
12472161	<b>K56G</b>	70.056.07	50.056.07
12472162	<b>K58G</b>	70.058.07	
12540328	<b>K80G</b>		
12540329	<b>K110G</b>		
12540330	<b>K120G</b>		
12541348	<b>K180E</b>	70.180.05	50.180.05
15510849	<b>K931L</b>	70.931.12	50.931.12
15512233	<b>K970R</b>	70.970.18	50.970.18
15512234	<b>KH901L</b>	78.901.12	58.901.12
15512235	<b>K901L</b>	70.901.12	50.901.12
15512239	<b>KG931R</b>	77.931.18	57.931.18
15521976	<b>K58G</b>	70.058.07	
15522020	<b>K56G</b>	70.056.07	50.056.07
15536398	<b>K55G</b>	70.055.07	50.055.07
15584763	<b>K56G</b>	70.056.07	50.056.07
15585841	<b>KH931L</b>	78.931.12	58.931.12
15618118	<b>KG931R</b>	77.931.18	57.931.18
19243453	<b>K180E</b>	70.180.05	50.180.05
85106184	<b>K122E</b>	70.122.05	50.122.05
88911967	<b>K56G</b>	70.056.07	50.056.07
88911968	<b>K56G</b>	70.056.07	50.056.07
88911998	<b>K120G</b>		
88936011	<b>K80R</b>	70.080.18	50.080.18
88936044	<b>K961L</b>	70.961.12	50.961.12
88936084	<b>K60R</b>		
88936119	<b>K70R</b>	70.070.18	50.070.18
88936144	<b>KG931R</b>	77.931.18	57.931.18
94058104	<b>K68Z</b>	70.068.26	
97723802	<b>K69Z</b>	70.069.26	
97782770	<b>K69Z</b>	70.069.26	
98438973	<b>K69Z</b>	70.069.26	

PART NO.	QWIKKIT	PLUSKIT	ECONO KIT
<b>CHEVROLET / GMC CONT.</b>			
98441181	<b>K69Z</b>	70.069.26	
98443583	<b>K69Z</b>	70.069.26	
98443939	<b>K69Z</b>	70.069.26	
98448583	<b>K68Z</b>	70.068.26	
IC-2-40	<b>K170G</b>		

PART NO.	QWIKKIT	PLUSKIT	ECONO KIT
----------	---------	---------	-----------

# KING PIN KIT INTERCHANGE

PART NO.	QWIKKIT	PLUSKIT	ECONO KIT
<b>DAYTON CONT.</b>			
300-266	K961L	70.961.12	50.961.12
300-267	K180E	70.180.05	50.180.05
300-268	K102I	70.102.09	50.102.09
300-269	K140I	70.140.09	50.140.09
300-270	K108I		50.108.09
300-271	K120I	70.120.09	50.120.09
300-273	K71F	70.071.06	50.071.06
300-274	K120E	70.120.05	50.120.05
300-275	K121E	70.121.05	50.121.05
300-276	K120I	70.120.09	50.120.09
300-277	K141S	70.141.19	50.141.19
300-278	K160S	70.160.19	50.160.19
300-279	K56G	70.056.07	50.056.07
300-280	K941F	70.941.06	50.941.06
300-281	K942FA		
300-282	K102I	70.102.09	50.102.09
300-283	K180E	70.180.05	50.180.05
300-284	K961L	70.961.12	50.961.12
300-285	K71F	70.071.06	50.071.06
300-286	K76F	70.076.06	50.076.06
300-287	K80G		
300-288	K110G		
300-289	K120G		
300-290	K122V		
300-291	K140V		
300-292	K146F		
300-293	K122E	70.122.05	50.122.05
300-294	K146E	70.146.05	50.146.05
300-295	K146E	70.146.05	50.146.05
300-296	K70D	70.070.04	50.070.04
300-297	K122E	70.122.05	50.122.05
300-298	K146S		
300-299	K981R	70.981.18	50.981.18
300-300	K942F	70.942.06	50.942.06
300-303	K123E	70.123.05	50.123.05
300-305	K147E	70.147.05	50.147.05
300-306	K147E	70.147.05	50.147.05
300-307	K146E	70.146.05	50.146.05
300-310	K180R	70.180.18	50.180.18
300-312	KH946R	78.946.18	58.946.18
300-314	K70R	70.070.18	50.070.18
300-316	K80R	70.080.18	50.080.18
300-317	K981R	70.981.18	50.981.18
300-318	K103S	70.103.19	50.103.19
300-319	K103S	70.103.19	50.103.19
300-324	K941R	70.941.18	50.941.18
300-325	K180E	70.180.05	50.180.05
300-329	K181R	70.181.18	50.181.18
300-330	K181R	70.181.18	50.181.18
300-332	KG931R	77.931.18	57.931.18
300-334	K120R	70.120.18	50.120.18
300-336		50.121.08	
308-216	KH931L	78.931.12	58.931.12
308-231	K533M	70.533.13	50.533.13
308-232	K931L	70.931.12	50.931.12
308-249	K140I	70.140.09	50.140.09
308-262	K942F	70.942.06	50.942.06
308-268	K102I	70.102.09	50.102.09
308-274	K120E	70.120.05	50.120.05
308-276	K120I	70.120.09	50.120.09
308-277	K141S	70.141.19	50.141.19
308-279	K56G	70.056.07	50.056.07
308-283	K180E	70.180.05	50.180.05
308-284	K961L	70.961.12	50.961.12

PART NO.	QWIKKIT	PLUSKIT	ECONO KIT
<b>DAYTON CONT.</b>			
308-286	K76F	70.076.06	50.076.06
308-297	K122E	70.122.05	50.122.05
308-305	K147E	70.147.05	50.147.05
308-317	K981R	70.981.18	50.981.18
308-318	K103S	70.103.19	50.103.19
308-331	KG931R	77.931.18	57.931.18
<b>DODGE</b>			
1643174	K125G	70.125.07	50.125.07
1692644	K50F	70.053.06	50.053.06
1818726	KD901R	74.901.18	54.901.18
1843208	K70D	70.070.04	50.070.04
2808618	K901L	70.901.12	50.901.12
<b>E-ONE</b>			
513823	KH931L	78.931.12	58.931.12
<b>EATON</b>			
316111	K122E	70.122.05	50.122.05
328342	K122E	70.122.05	50.122.05
328343	K146E	70.146.05	50.146.05
328344	K122E	70.122.05	50.122.05
328345	K146E	70.146.05	50.146.05
328346	K123E	70.123.05	50.123.05
328347	K147E	70.147.05	50.147.05
328348	K123E	70.123.05	50.123.05
328349	K147E	70.147.05	50.147.05
329022	K141S	70.141.19	50.141.19
329023	K160S	70.160.19	50.160.19
329116	K162S		
329182	K103S	70.103.19	50.103.19
329404	K146E	70.146.05	50.146.05
329405	K146E	70.146.05	50.146.05
329432	K180E	70.180.05	50.180.05
329433	K180E	70.180.05	50.180.05
331434	K200S		
331435	K201S		
503700	K145E		
524530	K146E	70.146.05	50.146.05
806355	K120E	70.120.05	50.120.05
806356	K121E	70.121.05	50.121.05
811525	K180E	70.180.05	50.180.05
815984	K120E	70.120.05	50.120.05
823078	K122E	70.122.05	50.122.05
823946	K146E	70.146.05	50.146.05
824530	K146E	70.146.05	50.146.05
824920	K146E	70.146.05	50.146.05
1008431	K120E	70.120.05	50.120.05
1008500	K180E	70.180.05	50.180.05
8063558	K120E	70.120.05	50.120.05
<b>EATON TOP SPEC</b>			
KP2230	K533M	70.533.13	50.533.13
KP2262	K981	70.098.09	50.098.09
KP2266	K125G	70.125.07	50.125.07
KP2268	K95G	70.095.07	50.095.07
KP2271	K125G	70.125.07	50.125.07
KP2272	K120W		
KP2275	K901L	70.901.12	50.901.12
KP2276	K95G	70.095.07	50.095.07
KP2277	K51G		
KP2278	K51G		
KP2279	K70G	70.070.07	50.070.07
KP2280	K70G	70.070.07	50.070.07
KP2281	K51G		
KP2283	K70F	70.073.06	50.053.06
KP2284	K70F	70.073.06	50.053.06
KP2285	K109I		50.109.09

PART NO.	QWIKKIT	PLUSKIT	ECONO KIT
<b>EATON TOP SPEC CONT.</b>			
KP2288	KD901R	74.901.18	54.901.18
KP2289	K70D	70.070.04	50.070.04
KP2290	K70D	70.070.04	50.070.04
KP2291	K970R	70.970.18	50.970.18
KP2292	K901L	70.901.12	50.901.12
KP2293	K109I		50.109.09
KP2294	KD901R	74.901.18	54.901.18
KP2296	KH901L	78.901.12	58.901.12
KP2297	KH901L	78.901.12	58.901.12
KP2298	K970R	70.970.18	50.970.18
KP2305	K921L	70.921.12	50.921.12
KP2311	K140I	70.140.09	50.140.09
KP2312	K140I	70.140.09	50.140.09
KP2313	K75F	70.075.06	50.075.06
KP2314	KH931L	78.931.12	58.931.12
KP2315	K941F	70.941.06	50.941.06
KP2316	K95F	70.095.06	
KP2317	K55G	70.055.07	50.055.07
KP2318	K55G	70.055.07	50.055.07
KP2319	KE350F	75.350.06	55.350.06
KP2320	K101I	70.101.09	50.101.09
KP2321	K941F	70.941.06	50.941.06
KP2322	K108I		50.108.09
KP2323	K139I	70.139.09	50.139.09
KP2324	K139I	70.139.09	50.139.09
KP2325	K309I	70.309.09	50.309.09
KP2326	K309I	70.309.09	50.309.09
KP2327	K931L	70.931.12	50.931.12
KP2329	K535M		
KP2330	K533M	70.533.13	50.533.13
KP2331	K121G	70.121.07	50.121.07
KP2333	K126W	70.126.23	50.126.23
KP2334	K125W	70.125.23	50.125.23
KP2336	K616M	70.616.13	50.616.13
KP2337	K310I	70.310.09	50.310.09
KP2338	K931L	70.931.12	50.931.12
KP2339	K971R		
KP2340	K140I	70.140.09	50.140.09
KP2341	K120E	70.120.05	50.120.05
KP2342	K180E	70.180.05	50.180.05
KP2343	KE350F	75.350.06	55.350.06
KP2344	K50F	70.053.06	50.053.06
KP2365	K139I	70.139.09	50.139.09
KP2748	KH931L	78.931.12	58.931.12
KP2924	KG931R	77.931.18	57.931.18
KP2983	K50F	70.053.06	50.053.06
KP2985	K51G		
KP2987	K55G	70.055.07	50.055.07
KP2990	K70D	70.070.04	50.070.04
KP2991	K70F	70.073.06	50.053.06
KP2992	K70G	70.070.07	50.070.07
KP2994	K75F	70.075.06	50.075.06
KP2996	K95F	70.095.06	50.095.06
KP2997	K95G	70.095.07	50.095.07
KP2998	K981	70.098.09	50.098.09
KP3000	K101I	70.101.09	50.101.09
KP3001	K108I		50.108.09
KP3002	K109I		50.109.09
KP3004	K120E	70.120.05	50.120.05
KP3006	K120W		
KP3007	K121G	70.121.07	50.121.07
KP3008	K125G	70.125.07	50.125.07
KP3009	K125W	70.125.23	50.125.23
KP3010	K126W	70.126.23	50.126.23

PART NO.	QWIKKIT	PLUSKIT	ECONO KIT
<b>EATON TOP SPEC CONT.</b>			
KP3011	K139I	70.139.09	50.139.09
KP3012	K140I	70.140.09	50.140.09
KP3014	K170G		
KP3019	K309I	70.309.09	50.309.09
KP3020	K310I	70.310.09	50.310.09
KP3023	KE350F	75.350.06	55.350.06
KP3026	K533M	70.533.13	50.533.13
KP3028	K535M		
KP3030	K616M	70.616.13	50.616.13
KP3032	K901L	70.901.12	50.901.12
KP3033	KD901R	74.901.18	54.901.18
KP3034	KH901L	78.901.12	58.901.12
KP3035	K921L	70.921.12	50.921.12
KP3037	K941F	70.941.06	50.941.06
KP3038	K931L	70.931.12	50.931.12
KP3039	KH931L	78.931.12	58.931.12
KP3040	K970R	70.970.18	50.970.18
KP3041	K971R		
KP3130	K120E	70.120.05	50.120.05
KP3133	KG931R	77.931.18	57.931.18
KP3134	K56G	70.056.07	50.056.07
<b>ELGIN</b>			
KB325	K140I	70.140.09	50.140.09
KB325N	K140I	70.140.09	50.140.09
KB424	K109I		50.109.09
KB425	K109I		50.109.09
KB425CB	K109I		50.109.09
KB450	K125G	70.125.07	50.125.07
KB450A	K125G	70.125.07	50.125.07
KB450AN	K125G	70.125.07	50.125.07
KB458CB	K941F	70.941.06	50.941.06
KB462B	K51G		
KB463	K95G	70.095.07	50.095.07
KB463N	K95G	70.095.07	50.095.07
KB465A	KD901R	74.901.18	54.901.18
KB465AN	KD901R	74.901.18	54.901.18
KB477A	K70D	70.070.04	50.070.04
KB477AN	K70D	70.070.04	50.070.04
KB477ANR	K70D	70.070.04	50.070.04
KB477AR	K70D	70.070.04	50.070.04
KB479X	K120W		
KB491A	K51G		
KB491AN	K51G		
KB492	K70G	70.070.07	50.070.07
KB492A	K70G	70.070.07	50.070.07
KB492AN	K70G	70.070.07	50.070.07
KB493	K50F	70.053.06	50.053.06
KB504	K901L	70.901.12	50.901.12
KB504N	K901L		

# KING PIN KIT INTERCHANGE

PART NO.	QWIKKIT	PLUSKIT	ECONO KIT
<b>EUCLID CONT.</b>			
E-6451B	<b>KE350F</b>	75.350.06	55.350.06
E-6454B	<b>K56G</b>	70.056.07	50.056.07
E-6455B	<b>K71F</b>	70.071.06	50.071.06
E-6868B	<b>KG931R</b>	77.931.18	57.931.18
E-6869B	<b>K121E</b>	70.121.05	50.121.05
E-6869C	<b>K121E</b>	70.121.05	50.121.05
E-6875C	<b>K140I</b>	70.140.09	50.140.09
E-6876C	<b>K108I</b>		50.108.09
E-9312B	<b>K901L</b>	70.901.12	50.901.12
E-9941B	<b>K120I</b>	70.120.09	50.120.09
E-9942B	<b>K141S</b>	70.141.19	50.141.19
E-9943B	<b>K76F</b>	70.076.06	50.076.06
E-9944B	<b>K942F</b>	70.942.06	50.942.06
E-9945B	<b>K146F</b>		

PART NO.	QWIKKIT	PLUSKIT	ECONO KIT
<b>FLAGG</b>			
FKP-100-C	<b>KG931R</b>	77.931.18	57.931.18
FKP-101-C	<b>K121E</b>	70.121.05	50.121.05
FKP-102-C	<b>K56G</b>	70.056.07	50.056.07
FKP-103-B	<b>K71F</b>	70.071.06	50.071.06
FKP-104-B	<b>K72F</b>	70.072.06	50.072.06
FKP-105-B	<b>K942F</b>	70.942.06	50.942.06
FKP-106-B	<b>K96F</b>	70.096.06	50.096.06
FKP-107-C	<b>K941F</b>	70.941.06	50.941.06
FKP-108-C	<b>K941F</b>	70.941.06	50.941.06
FKP-109-B	<b>K180E</b>	70.180.05	50.180.05
FKP-110-B	<b>K102I</b>	70.102.09	50.102.09
FKP-111-B	<b>K961L</b>	70.961.12	50.961.12
FKP-111-C	<b>K961L</b>	70.961.12	50.961.12
FKP-112-B	<b>K108I</b>		50.108.09
FKP-113-C	<b>K140I</b>	70.140.09	50.140.09
FKP-114-B	<b>K51G</b>		
FKP-115-B	<b>K120E</b>	70.120.05	50.120.05
FKP-116-B	<b>K121E</b>	70.121.05	50.121.05
FKP-117-B	<b>K56G</b>	70.056.07	50.056.07
FKP-118-B	<b>K120I</b>	70.120.09	50.120.09
FKP-119-B	<b>K141S</b>	70.141.19	50.141.19
FKP-11-B	<b>K125G</b>	70.125.07	50.125.07
FKP-120-B	<b>K76F</b>	70.076.06	50.076.06
FKP-121-B	<b>K80G</b>		
FKP-122-B	<b>K110G</b>		
FKP-123-B	<b>K120G</b>		
FKP-124B	<b>K146F</b>		
FKP-125-C	<b>K942F</b>	70.942.06	50.942.06
FKP-126-C	<b>K122V</b>		
FKP-127-C	<b>K140V</b>		
FKP-128-C	<b>K942F</b>	70.942.06	50.942.06
FKP-129-B	<b>K942FA</b>		
FKP-130-B	<b>K160S</b>	70.160.19	50.160.19
FKP-130-C	<b>K160S</b>	70.160.19	50.160.19
FKP-131-B	<b>K122E</b>	70.122.05	50.122.05
FKP-132-B	<b>K146E</b>	70.146.05	50.146.05
FKP-133-C	<b>K146E</b>	70.146.05	50.146.05
FKP-134-C	<b>K146S</b>		
FKP-135-C	<b>K139I</b>	70.139.09	50.139.09
FKP-136-C	<b>K981R</b>	70.981.18	50.981.18
FKP-137-B	<b>K126W</b>	70.126.23	50.126.23
FKP-139-B	<b>K123E</b>	70.123.05	50.123.05
FKP-140-C	<b>KH946R</b>	78.946.18	58.946.18
FKP-141-C	<b>K180R</b>	70.180.18	50.180.18
FKP-142-C	<b>K80R</b>	70.080.18	50.080.18
FKP-143-C	<b>K70R</b>	70.070.18	50.070.18
FKP-144-B	<b>K147E</b>	70.147.05	50.147.05
FKP-145-C	<b>K103S</b>	70.103.19	50.103.19
FKP-146-C	<b>K941R</b>	70.941.18	50.941.18

PART NO.	QWIKKIT	PLUSKIT	ECONO KIT
<b>FLAGG CONT.</b>			
FKP-152-C	<b>K160S</b>	70.160.19	50.160.19
FKP-153-B	<b>K122E</b>	70.122.05	50.122.05
FKP-155-B	<b>K72F</b>	70.072.06	50.072.06
FKP-157-C	<b>K60R</b>		
FKP-158-C	<b>K181R</b>	70.181.18	50.181.18
FKP-27-B	<b>K95G</b>	70.095.07	50.095.07
FKP-34-B	<b>K70F</b>	70.073.06	50.073.06
FKP-36-B	<b>K50F</b>	70.053.06	50.053.06
FKP-37-B	<b>K901L</b>	70.901.12	50.901.12
FKP-38-B	<b>K51G</b>		
FKP-39-B	<b>K70G</b>	70.070.07	50.070.07
FKP-40-B	<b>K51G</b>		
FKP-43-B	<b>K70F</b>	70.073.06	50.073.06
FKP-44-B	<b>K109I</b>		50.109.09
FKP-46-B	<b>K70D</b>	70.070.04	50.070.04
FKP-49-B	<b>K970R</b>	70.970.18	50.970.18
FKP-4-B	<b>K51G</b>		
FKP-50-B	<b>K901L</b>	70.901.12	50.901.12
FKP-51-B	<b>K109I</b>		50.109.09
FKP-52-B	<b>KH901L</b>	78.901.12	58.901.12
FKP-53-B	<b>KD901R</b>	74.901.18	54.901.18
FKP-54-B	<b>K70F</b>	70.073.06	50.073.06
FKP-59-B	<b>K120W</b>		
FKP-62-B	<b>K921L</b>	70.921.12	50.921.12
FKP-68-B	<b>K140I</b>	70.140.09	50.140.09
FKP-69-B	<b>K75F</b>	70.075.06	50.075.06
FKP-70-B	<b>K55G</b>	70.055.07	50.055.07
FKP-71-B	<b>KH931L</b>	78.931.12	58.931.12
FKP-72-B	<b>K941F</b>	70.941.06	50.941.06
FKP-73-B	<b>K95F</b>	70.095.06	50.095.06
FKP-74-B	<b>KE350F</b>	75.350.06	55.350.06
FKP-75-B	<b>K101I</b>	70.101.09	50.101.09
FKP-76-B	<b>K108I</b>		50.108.09
FKP-77-B	<b>K139I</b>	70.139.09	50.139.09
FKP-78-B	<b>K309I</b>	70.309.09	50.309.09
FKP-79-B	<b>K941FA</b>		
FKP-81-B	<b>KE350F</b>	75.350.06	55.350.06
FKP-82-B	<b>K98I</b>	70.098.09	50.098.09
FKP-84-B	<b>K535M</b>		
FKP-85-B	<b>K533M</b>	70.533.13	50.533.13
FKP-86-B	<b>K121G</b>	70.121.07	50.121.07
FKP-88-B	<b>K126W</b>	70.126.23	50.126.23
FKP-89-B	<b>K125W</b>	70.125.23	50.125.23
FKP-8-B	<b>K98I</b>	70.098.09	50.098.09
FKP-90-B	<b>K931L</b>	70.931.12	50.931.12
FKP-91-B	<b>K310I</b>	70.310.09	50.310.09
FKP-92-B	<b>KG931R</b>	77.931.18	57.931.18
FKP-93-B	<b>K971R</b>		
FKP-94-B	<b>K616M</b>	70.616.13	50.616.13
FKP-96-B	<b>K140I</b>	70.140.09	50.140.09
FKP-97-C	<b>K931L</b>	70.931.12	50.931.12
FKP-98-C	<b>K120E</b>	70.120.05	50.120.05
FKP-99-C	<b>KH931L</b>	78.931.12	58.931.12

PART NO.	QWIKKIT	PLUSKIT	ECONO KIT
<b>FLEETRITE</b>			
FAK4444	<b>K51G</b>		
FAK4446	<b>K98I</b>	70.098.09	50.098.09
FAK4454	<b>K95G</b>	70.095.07	50.095.07
FAK4460	<b>K120W</b>		
FAK4461	<b>K50F</b>	70.053.06	50.053.06
FAK4465	<b>K95G</b>	70.095.07	50.095.07
FAK4467	<b>K70G</b>	70.070.07	50.070.07
FAK4468	<b>K70G</b>	70.070.07	50.070.07
FAK4469	<b>K51G</b>		
FAK4470	<b>K51G</b>		

PART NO.	QWIKKIT	PLUSKIT	ECONO KIT
<b>FLEETRITE CONT.</b>			
FAK4471	<b>K70F</b>	70.073.06	50.073.06
FAK4472	<b>K70F</b>	70.073.06	50.073.06
FAK4474	<b>K109I</b>		50.109.09
FAK4477	<b>K109I</b>		50.109.09
FAK4485	<b>K140I</b>	70.140.09	50.140.09
FAK4487	<b>K75F</b>	70.075.06	50.075.06
FAK4488	<b>K55G</b>	70.055.07	50.055.07
FAK4489	<b>K55G</b>	70.055.07	50.055.07
FAK4492	<b>KE350F</b>	75.350.06	55.350.06
FAK4493	<b>K95F</b>	70.095.06	
FAK4494	<b>K941F</b>	70.941.06	50.941.06
FAK4495	<b>K101I</b>	70.101.09	50.101.09
FAK4497	<b>K108I</b>		50.108.09
FAK4498	<b>K139I</b>	70.139.09	50.139.09
FAK4500	<b>K309I</b>	70.309.09	50.309.09
FAK4504	<b>K941FA</b>		
FAK4505	<b>KE350F</b>	75.350.06	55.350.06
FAK4507	<b>K535M</b>		
FAK4508	<b>K533M</b>	70.533.13	50.533.13
FAK4509	<b>K121G</b>	70.121.07	50.121.07
FAK4510	<b>K125W</b>	70.125.23	50.125.23
FAK4511	<b>K126W</b>	70.126.23	50.126.23
FAK4514	<b>K616M</b>	70.616.13	50.616.13
FAK4516	<b>K310I</b>	70.310.09	50.310.09
FAK4517	<b>K140I</b>	70.140.09	50.140.09
FAK4518	<b>K139I</b>	70.139.09	50.139.09
FAK4526	<b>K170G</b>		
FAK4527	<b>K125G</b>	70.125.07	50.125.07
FAK4531	<b>KD901R</b>	74.901.18	54.901.18
FAK4532	<b>K70D</b>	70.070.04	50.070.04
FAK4533	<b>K125G</b>	70.125.07	50.125.07
FAK4536	<b>KD901R</b>	74.901.18	54.901.18
FAK4537	<b>K70D</b>	70.070.04	50.070.04
FAK4538	<b>K970R</b>	70.970.18	50.970.18
FAK4539	<b>K970R</b>	70.970.18	50.970.18
FAK4540	<b>K901L</b>	70.901.12	50.901.12
FAK4541	<b>KH901L</b>	78.901.12	58.901.12
FAK4542	<b>KH901L</b>	78.901.12	58.901.12
FAK4544	<b>K901L</b>	70.901.12	50.901.12
FAK4546	<b>K109I</b>		50.109.09
FAK4548	<b>KD901R</b>	74.901.18	54.901.18
FAK4549	<b>K125G</b>	70.125.07	50.125.07
FAK4550	<b>K970R</b>	70.970.18	50.970.18
FAK4551	<b>K901L</b>	70.901.12	50.901.12
FAK4552	<b>KH901L</b>	78.901.12	58.901.12
FAK4553	<b>K921L</b>	70.921.12	50.921.12
FAK4555	<b>K931L</b>	70.931.12	50.931.12
FAK4558	<b>KH931L</b>	78.931.12	58.931.12
FAK4559	<b>K921L</b>	70.921.12	50.921.12
FAK4560	<b>K971R</b>		
FAK4561	<b>K931L</b>	70.931.12	50.931.12
FAK4564	<b>K931L</b>	70.931.12	50.931.12
FAK4566	<b>KG931R</b>	77.931.18	57.931.18
FAK4567	<b>KG931R</b>	77.931.18	57.931.18
FAK4568	<b>KH931L</b>	78.931.12	58.931.12
FAK4569	<b>K70D</b>	70.070.04	50.070.04
FAK4570	<b>K961L</b>	70.961.12	50.961.12
FAK4571	<b>KH901L</b>	78.901.12	58.901.12
FAK4572	<b>K120E</b>	70.120.05	50.120.05
FAK4573	<b>K121E</b>	70.121.05	50.121.05
FAK4574	<b>K180E</b>	70.180.05	50.180.05
FAK4580	<b>K170G</b>		
FAK4582	<b>K102I</b>	70.102.09	50.102.09
FAK4583	<b>K120E</b>	70.120.05	50.120.05

PART NO.	QWIKKIT	PLUSKIT	ECONO KIT
<b>FLEETRITE CONT.</b>			
FAK4584	<b>K121E</b>	70.121.05	50.121.05
FAK4585	<b>K51G</b>		
FAK4586	<b>K72F</b>	70.072.06	50.072.06
FAK4587	<b>K942F</b>	70.942.06	50.942.06</

# KING PIN KIT INTERCHANGE

PART NO.	QWIKKIT	PLUSKIT	ECONO KIT
<b>HD PLUS</b>			
HKP2025	K98I	70.098.09	50.098.09
HKP2030	K125G	70.125.07	50.125.07
HKP2055	K95G	70.095.07	50.095.07
HKP2065	K50F	70.053.06	50.053.06
HKP2070	K901L	70.901.12	50.901.12
HKP2075	K51G		
HKP2080	K70G	70.070.07	50.070.07
HKP2090	K51G		
HKP2095	K70F	70.073.06	50.073.06
HKP2110	K70F	70.073.06	50.073.06
HKP2115	K970R	70.970.18	50.970.18
HKP2120	K901L	70.901.12	50.901.12
HKP2125	KH901L	78.901.12	58.901.12
HKP2130	KH901L	78.901.12	58.901.12
HKP2135	KH901L	78.901.12	58.901.12
HKP2160	K921L	70.921.12	50.921.12
HKP2180	K140I	70.140.09	50.140.09
HKP2185	K75F	70.075.06	50.075.06
HKP2190	K55G	70.055.07	50.055.07
HKP2200	KH931L	78.931.12	58.931.12
HKP2205	K941F	70.941.06	50.941.06
HKP2210	K95F	70.095.06	50.095.06
HKP2220	K101I	70.101.09	50.101.09
HKP2230	K108I		
HKP2235	K139I	70.139.09	50.139.09
HKP2245	K309I	70.309.09	50.309.09
HKP2250	K941FA		
HKP2270	K931L	70.931.12	50.931.12
HKP2275	K535M		
HKP2280	K533M	70.533.13	50.533.13
HKP2285	K126W	70.126.23	50.126.23
HKP2295	KG931R	77.931.18	57.931.18
HKP2300	KG931R	77.931.18	57.931.18
HKP2305	K971R		
HKP2310	K121G	70.121.07	50.121.07
HKP2315	K140I	70.140.09	50.140.09
HKP2320	K120E	70.120.05	50.120.05
HKP2335	K121E	70.121.05	50.121.05
HKP2340	K616M	70.616.13	50.616.13
HKP2345	K102I	70.102.09	50.102.09
HKP2350	K961L	70.961.12	50.961.12
HKP2355	K72F	70.072.06	50.072.06
HKP2360	K96F	70.096.06	50.096.06
HKP2365	K942F	70.942.06	50.942.06
HKP2370	K70D	70.070.04	50.070.04
HKP2375	K120E	70.120.05	50.120.05
HKP2380	K121E	70.121.05	50.121.05
HKP2390	K310I	70.310.09	50.310.09
HKP2400	K56G	70.056.07	50.056.07
HKP2435	K70D	70.070.04	50.070.04
HKP2640	K120W		
HKP2660	K125G	70.125.07	50.125.07
HKP2665	K70G	70.070.07	50.070.07
HKP2670	K70G	70.070.07	50.070.07
HKP2685	KD901R	74.901.18	54.901.18
HKP2690	KD901R	74.901.18	54.901.18
HKP2695	K95G	70.095.07	50.095.07
HKP2730	K70D	70.070.04	50.070.04
HKP2735	K70G	70.070.07	50.070.07
HKP2740	K51G		
HKP2745	K51G		
HKP2750	K51G		
HKP2815	K970R	70.970.18	50.970.18
HKP2840	K140I	70.140.09	50.140.09

PART NO.	QWIKKIT	PLUSKIT	ECONO KIT
<b>HD PLUS CONT.</b>			
HKP2855	K55G	70.055.07	50.055.07
HKP2860	KH901L	78.901.12	58.901.12
HKP2875	K101I	70.101.09	50.101.09
HKP2880	K101I	70.101.09	50.101.09
HKP2885	K102I	70.102.09	50.102.09
HKP2890	K108I		
HKP2895	K139I	70.139.09	50.139.09
HKP2900	K139I	70.139.09	50.139.09
HKP2905	K139I	70.139.09	50.139.09
HKP2910	K309I	70.309.09	50.309.09
HKP2915	K309I	70.309.09	50.309.09
HKP2930	K931L	70.931.12	50.931.12
HKP2935	K125W	70.125.23	50.125.23
HKP2945	K121G	70.121.07	50.121.07
HKP2950	K310I	70.310.09	50.310.09
HKP2955	K310I	70.310.09	50.310.09
HKP2970	KD901R	74.901.18	54.901.18
HKP2975	K931L	70.931.12	50.931.12
HKP2995	KH931L	78.931.12	58.931.12
HKP3000	K941F	70.941.06	50.941.06
HKP3005	K180E	70.180.05	50.180.05
HKP3010	K180E	70.180.05	50.180.05
HKP3015	K102I	70.102.09	50.102.09
HKP3025	K961L	70.961.12	50.961.12
HKP3030	K961L	70.961.12	50.961.12
HKP3040	K108I		
HKP3045	K941FA		
HKP3050	K120I	70.120.09	50.120.09
HKP3055	K120I	70.120.09	50.120.09
HKP3060	K141S	70.141.19	50.141.19
HKP3065	K942FA		
HKP3070	K76F	70.076.06	50.076.06
HKP3080	K120E	70.120.05	50.120.05
HKP3085	K121E	70.121.05	50.121.05
HKP3090	K146F		
HKP3095	K180E	70.180.05	50.180.05
HKP3100	K80G		
HKP3105	K110G		
HKP3110	K120G		
HKP3125	K141S	70.141.19	50.141.19
HKP3130	K942F	70.942.06	50.942.06
HKP3135	K942FA		
HKP3150	K160S	70.160.19	50.160.19
HKP3155	K122E	70.122.05	50.122.05
HKP3160	K146E	70.146.05	50.146.05
HKP3165	K146E	70.146.05	50.146.05
HKP3170	K139I	70.139.09	50.139.09
HKP3175	K180E	70.180.05	50.180.05
HKP3190	K122V		
HKP3195	K102I	70.102.09	50.102.09
HKP3200	K160S	70.160.19	50.160.19
HKP3235	K50F	70.073.06	50.053.06
HKP3240	K901L	70.901.12	50.901.12
HKP3250	K109I		
HKP3290	K101I	70.101.09	50.101.09
HKP3295	K139I	70.139.09	50.139.09
HKP3385	K981R	70.981.18	50.981.18
HKP3395	K146S		
HKP3450	K147E	70.147.05	50.147.05
HKP3500	K180R	70.180.18	50.180.18
<b>HENDRICKSON</b>			
001434	K127W	70.127.23	50.127.23
002916	K126W	70.126.23	50.126.23
003200	K120H		

PART NO.	QWIKKIT	PLUSKIT	ECONO KIT
<b>HENDRICKSON CONT.</b>			
003270	K120H		
006648	K131H		
60961-040			50.121.08
<b>IMT / INGERSOLL</b>			
700040	K700T	70.700.20	
<b>ISUZU</b>			
94058104	K68Z	70.068.26	
97782770	K69Z	70.069.26	
98438973	K69Z	70.069.26	
98443939	K69Z	70.069.26	
98448583	K68Z	70.068.26	
987441181	K69Z	70.069.26	
997723802	K69Z	70.069.26	
5-87830978-2	K68Z	70.068.26	
5-87830978-5	K68Z	70.068.26	
5-87831608-1	K69Z	70.069.26	
5-87832183-2	K69Z	70.069.26	
5-87832209-0	K69Z	70.069.26	
5-87832211	K69Z	70.069.26	
5-87832219-0	K69Z	70.069.26	
5-87832219-1	K69Z	70.069.26	
5-87832220-0	K69Z	70.069.26	
<b>KENWORTH</b>			
123	K125G	70.125.07	50.125.07
144	K125G	70.125.07	50.125.07
156	K970R	70.970.18	50.970.18
157	K970R	70.970.18	50.970.18
167	K901L	70.901.12	50.901.12
168	KH901L	78.901.12	58.901.12
170	KH901L	78.901.12	58.901.12
172	K901L	70.901.12	50.901.12
195	K931L	70.931.12	50.931.12
198	KH931L	78.931.12	58.931.12
199	K921L	70.921.12	50.921.12
1300	K971R		
1307	K931L	70.931.12	50.931.12
<b>KGI</b>			
579-1044	K150KG		
KA531	K230KG	70.230.07	
<b>KIMBLE</b>			
1170860	K127W	70.127.23	50.127.23
1170859	K126W	70.126.23	50.126.23
741-12001-71	K149E		
<b>MACK</b>			
195	K931L	70.931.12	50.931.12
198	KH931L	78.931.12	58.931.12
205S012	KH901L	78.901.12	58.901.12
205S015	K921L	70.921.12	50.921.12
250S011	K125G	70.125.07	50.125.07
301SQ28E	K535M		
301SQ44	KH901L	78.901.12	58.901.12
301SQ46A	K535M		
301SQ46B	K535M		
301SQ47B	K533M	70.533.13	50.533.13
301SQ47CPI	K533M	70.533.13	50.533.13
301SQ47D	K533M	70.533.13	50.533.13
301SQ47E	K533M	70.533.13	50.533.13
301SQ52	K616M	70.616.13	50.616.13
301SQ52A	K616M	70.616.13	50.616.13
301SQ53	K536M		
312SQ46B	K535M		
50.00.336305	K75M		
<b>MAN</b>			
81.44205-6013	K120N		

PART NO.	QWIKKIT	PLUSKIT	ECONO KIT
<b>MCI BUS</b>			
01-01-1017	KH946R	78.946.18	58.946.18
01-01-1079	KH946R	78.946.18	58.946.18
39470254-7	K961L	70.961.12	50.961.12
1J-2-54	KG931R	77.931.18	57.931.18
<b>MITSUBISHI</b>			
MC992486	K60U		
MK703748	K60U		
<b>MOOG</b>			
8343B	K51G		
8355B	K98I	70.098.09	50.098.09
8375B	K98I	70.098.09	50.098.09
8375T	K98I	70.098.09	50.098.09
8386B	K125G	70.125.07	50.125.07
8386N	K125G	70.125.07	50.125.07
8460B	KD901R	74.901.18	54.901.18
8460N	KD901R	74.901.18	54.901.18
8462B	K95G	70.095.07	50.095.07
8462N	K95G	70.095.07	50.095.07
8464B	K51G		
8467	K70D	70.070.04	50.070.04
8476B	K120W		
8478B	K535M		
8479B	K70D	70.070.04	50.070.04
8479N	K70D	70.070.04	50.070.04
8483B	K970R	70.970.18	50.970.18
8483N	K970R	70.970.18	50.970.18
8484T	K51G		
8486T	K70G	70.070.07	50.070.07
8488B	K50F	70.053.06	50.053.06
8489B	K901L	70.901.12	50.901.12
8489N	K901L	70.901.12	50.901.12
8490T	K51G		
8491B	K70G	70.070.07	50.070.07
8491N	K70G	70.070.07	50.070.07
8492B	K51G		
8492N	K51G		
8493N	K70F	70.073.06	50.073.06
8500B	K70F	70.073.06	50.073.06
8500F	K70F	70.073.06	50.073.06
8500N	K70F	70.073.06	50.073.06
8502B	K109I		
8504B	KD901R	74.901.18	54.901.18
8507B	K70D	70.070.04	50.070.04
8507N	K70D	70.070.04	50.070.04
8509B	KE350F	75.350.06	55.350.06
8514B	K970R	70.970.18	50.970.18
8514N	K970R	70.970.18	50.970.18
8515B	K901L	70.901.12	50.901.12
8515N	K901L	70.901.12	50.901.12
8518B	KH901L	78.901.12	58.901.12
8518N	KH901L	78.901.12	58.901.12
8519B	KD901R	74.901.18	54.901.18
8519N	KD901R	74.901.18	54.901.18
8520B	K70F	70.073.06	50.073.06
8525B	K50F	70.053.06	50.053.06
8527B	K120W		
8536B	K125G	70.125.07	50.125.07
8536N	K125G	70.125.07	50.125.07
8553B	K921L	70.921.12	50.921.12
8567B	K140I	70.140.09	50.140.09
8567N	K140I	70.140.09	50.140.09
8568B	K75F	70.075.06	50.

# KING PIN KIT INTERCHANGE

PART NO.	QWIKKIT	PLUSKIT	ECONO KIT
<b>NAVISTAR CONT.</b>			
597258C91	<b>KH931L</b>	78.931.12	58.931.12
597556C91	<b>K931L</b>	70.931.12	50.931.12
61556R91	<b>K981</b>	70.098.09	50.098.09
69576R92	<b>K125G</b>	70.125.07	50.125.07
870148R91	<b>K901L</b>	70.901.12	50.901.12
870148R92	<b>K901L</b>	70.901.12	50.901.12
966157R91	<b>KH901L</b>	78.901.12	58.901.12
966157R92	<b>KH901L</b>	78.901.12	58.901.12
974021R91	<b>K125G</b>	70.125.07	50.125.07

<b>NEO PLAN</b>			
KL0800000-025	<b>K162S</b>		

<b>NEW FLYER</b>			
6313078	<b>K120N</b>		
6330169	<b>KH946R</b>	78.946.18	58.946.18

<b>NEW STAR S &amp; S</b>			
S-3596	<b>K1081</b>		50.108.09
S-3682	<b>K55G</b>	70.055.07	50.055.07
S-4483	<b>K120I</b>	70.120.09	50.120.09
S-4948	<b>K139I</b>	70.139.09	50.139.09
S-4949	<b>K309I</b>	70.309.09	50.309.09
S-4988	<b>K140I</b>	70.140.09	50.140.09
S-4996	<b>K981</b>	70.098.09	50.098.09
S-5134	<b>K310I</b>	70.310.09	50.310.09
S-5223	<b>K101I</b>	70.101.09	50.101.09
S-6072	<b>K533M</b>	70.533.13	50.533.13
S-6073	<b>K616M</b>	70.616.13	50.616.13
S-6485	<b>K120E</b>	70.120.05	50.120.05
S-6486	<b>K121E</b>	70.121.05	50.121.05
S-6488	<b>K70F</b>	70.073.06	50.073.06
S-6492	<b>K70D</b>	70.070.04	50.070.04
S-6494	<b>K70F</b>	70.073.06	50.073.06
S-6501	<b>KE350F</b>	75.350.06	55.350.06
S-6502	<b>K941F</b>	70.941.06	50.941.06
S-6503	<b>K95F</b>	70.095.06	50.095.06
S-6504	<b>K75F</b>	70.075.06	50.075.06
S-6634	<b>K51G</b>		
S-6635	<b>K70G</b>	70.070.07	50.070.07
S-6643	<b>K121G</b>	70.121.07	50.121.07
S-6663	<b>K109I</b>		50.109.09
S-6938	<b>KD901R</b>	74.901.18	54.901.18
S-6939	<b>K125G</b>	70.125.07	50.125.07
S-6942	<b>K970R</b>	70.970.18	50.970.18
S-6943	<b>K970R</b>	70.970.18	50.970.18
S-6944	<b>K901L</b>	70.901.12	50.901.12
S-6945	<b>KH901L</b>	78.901.12	58.901.12
S-6946	<b>KH901L</b>	78.901.12	58.901.12
S-6947	<b>K901L</b>	70.901.12	50.901.12
S-6948	<b>K931L</b>	70.931.12	50.931.12
S-6949	<b>KH931L</b>	78.931.12	58.931.12
S-6950	<b>K921L</b>	70.921.12	50.921.12
S-6963	<b>K971R</b>		
S-6964	<b>K931L</b>	70.931.12	50.931.12
S-6965	<b>KG931R</b>	77.931.18	57.931.18
S-7190	<b>K120W</b>		
S-7191	<b>K126W</b>	70.126.23	50.126.13
S-7463	<b>K140I</b>	70.140.09	50.140.09
S-7721	<b>K70G</b>	70.070.07	50.070.07
S-7801	<b>K140I</b>	70.140.09	50.140.09
S-8371	<b>K120E</b>	70.120.05	50.120.05
S-8513	<b>KG931R</b>	77.931.18	57.931.18
S-8529	<b>KH931L</b>	78.931.12	58.931.12
S-8678	<b>K961L</b>	70.961.12	50.961.12
S-9304	<b>K102I</b>	70.102.09	50.102.09
S-9365	<b>K180E</b>	70.180.05	50.180.05

PART NO.	QWIKKIT	PLUSKIT	ECONO KIT
<b>NEW STAR S &amp; S CONT.</b>			
S-9722	<b>K55G</b>	70.055.07	50.055.07
S-A482	<b>K102I</b>	70.102.09	50.102.09
S-A483	<b>K120I</b>	70.120.09	50.120.09
S-A484	<b>K141S</b>	70.141.19	50.141.19
S-A811	<b>K120I</b>	70.120.09	50.120.09
S-C119	<b>K981R</b>	70.981.18	50.981.18
S-C464	<b>K122E</b>	70.122.05	50.122.05
S-D562	<b>K122E</b>	70.122.05	50.122.05
S-D819	<b>K120G</b>		
S-F091	<b>K80G</b>		
S-F092	<b>K110G</b>		
S-F187	<b>K180E</b>	70.180.05	50.180.05

<b>OTTAWA</b>			
90013937	<b>K961L</b>	70.961.12	50.961.12

<b>PETERBILT</b>			
123	<b>K125G</b>	70.125.07	50.125.07
144	<b>K125G</b>	70.125.07	50.125.07
156	<b>K970R</b>	70.970.18	50.970.18
157	<b>K970R</b>	70.970.18	50.970.18
167	<b>K901L</b>	70.901.12	50.901.12
168	<b>KH901L</b>	78.901.12	58.901.12
170	<b>KH901L</b>	78.901.12	58.901.12
172	<b>K901L</b>	70.901.12	50.901.12
195	<b>K931L</b>	70.931.12	50.931.12
198	<b>KH931L</b>	78.931.12	58.931.12
199	<b>K921L</b>	70.921.12	50.921.12
1300	<b>K971R</b>		
1303	<b>K971R</b>		

<b>RIDEWELL</b>			
1660106	<b>KG931R</b>	77.931.18	57.931.18
16673258034	<b>K127W</b>	70.127.23	50.127.23

<b>ROCKWELL</b>			
17110	<b>KG931R</b>	77.931.18	57.931.18
17111	<b>KG931R</b>	77.931.18	57.931.18
R200001	<b>K51G</b>		
R200003	<b>K981</b>	70.098.09	50.098.09
R200011	<b>K95G</b>	70.095.07	50.095.07
R200017	<b>K120W</b>		
R200018	<b>K50F</b>	70.053.06	50.053.06
R200022	<b>K95G</b>	70.095.07	50.095.07
R200024	<b>K70G</b>	70.070.07	50.070.07
R200025	<b>K70G</b>	70.070.07	50.070.07
R200026	<b>K51G</b>		
R200027	<b>K51G</b>		
R200028	<b>K70F</b>	70.073.06	50.073.06
R200029	<b>K70F</b>	70.073.06	50.073.06
R200031	<b>K109I</b>		50.109.09
R200034	<b>K109I</b>		50.109.09
R200042	<b>K140I</b>	70.140.09	50.140.09
R200043	<b>K140I</b>	70.140.09	50.140.09
R200044	<b>K75F</b>	70.075.06	50.075.06
R200045	<b>K55G</b>	70.055.07	50.055.07
R200046	<b>K55G</b>	70.055.07	50.055.07
R200049	<b>KE350F</b>	75.350.06	55.350.06
R200050	<b>K95F</b>	70.095.06	50.095.06
R200051	<b>K941F</b>	70.941.06	50.941.06
R200052	<b>K101I</b>	70.101.09	50.101.09
R200054	<b>K1081</b>		50.108.09
R200055	<b>K139I</b>	70.139.09	50.139.09
R200056	<b>K139I</b>	70.139.09	50.139.09
R200057	<b>K309I</b>	70.309.09	50.309.09
R200058	<b>K309I</b>	70.309.09	50.309.09
R200061	<b>K941FA</b>		
R200062	<b>KE350F</b>	75.350.06	55.350.06

PART NO.	QWIKKIT	PLUSKIT	ECONO KIT
<b>ROCKWELL CONT.</b>			
R200064	<b>K535M</b>		
R200065	<b>K533M</b>	70.533.13	50.533.13
R200066	<b>K121G</b>	70.121.07	50.121.07
R200067	<b>K125W</b>	70.125.23	50.125.23
R200068	<b>K126W</b>	70.126.23	50.126.23
R200071	<b>K616M</b>	70.616.13	50.616.13
R200073	<b>K310I</b>	70.310.09	50.310.09
R200074	<b>K140I</b>	70.140.09	50.140.09
R200075	<b>K139I</b>	70.139.09	50.139.09
R200121	<b>K170G</b>		
R200123	<b>K125G</b>	70.125.07	50.125.07
R200138	<b>KD901R</b>	74.901.18	54.901.18
R200142	<b>KD901R</b>	74.901.18	54.901.18
R200143	<b>K70D</b>	70.070.04	50.070.04
R200144	<b>K125G</b>	70.125.07	50.125.07
R200145	<b>K170G</b>		
R200152	<b>K125G</b>	70.125.07	50.125.07
R200154	<b>KD901R</b>	74.901.18	54.901.18
R200155	<b>K70D</b>	70.070.04	50.070.04
R200156	<b>K970R</b>	70.970.18	50.970.18
R200157	<b>K970R</b>	70.970.18	50.970.18
R200163	<b>K901L</b>	70.901.12	50.901.12
R200167	<b>K901L</b>	70.901.12	50.901.12
R200168	<b>KH901L</b>	78.901.12	58.901.12
R200170	<b>KH901L</b>	78.901.12	58.901.12
R200172	<b>K901L</b>	70.901.12	50.901.12
R200174	<b>K109I</b>	50.109.09	
R200184	<b>KD901R</b>	74.901.18	54.901.18
R200186	<b>K125G</b>	70.125.07	50.125.07
R200188	<b>K970R</b>	70.970.18	50.970.18
R200189	<b>KH901L</b>	78.901.12	58.901.12
R200190	<b>K901L</b>	70.901.12	50.901.12
R200191	<b>KH901L</b>	78.901.12	58.901.12
R200193	<b>K921L</b>	70.921.12	50.921.12
R200195	<b>K931L</b>	70.931.12	50.931.12
R200198	<b>KH931L</b>	78.931.12	58.931.12
R200199	<b>K921L</b>	70.921.12	50.921.12
R200250	<b>K180E</b>	70.180.05	50.180.05
R200251	<b>K121E</b>	70.121.05	50.121.05
R200267	<b>K120E</b>	70.120.05	50.120.05
R200268	<b>K102I</b>	70.102.09	50.102.09
R200269	<b>K120E</b>	70.120.05	50.120.05
R200270	<b>K121E</b>	70.121.05	50.121.05
R200271	<b>K51G</b>		
R200272	<b>K72F</b>	70.072.06	50.072.06
R200273	<b>K942F</b>	70.942.06	50.942.06
R200274	<b>K941F</b>	70.941.06	50.941.06
R200275	<b>K96F</b>	70.096.06	50.096.06
R200276	<b>K941F</b>	70.941.06	50.941.06
R200277	<b>K1081</b>		50.108.09
R200278	<b>K140I</b>	70.140.09	50.140.09
R200279	<b>K160S</b>	70.160.19	50.160.19
R200280	<b>K76F</b>	70.076.06	50.076.06
R200281	<b>K122E</b>	70.122.05	50.122.05
R200282	<b>K80G</b>		
R200283	<b>K110G</b>		
R200284	<b>K120G</b>		
R200285	<b>KH931L</b>	78.931.12	58.931.12
R2002916	<b>K127W</b>	70.127.23	50.127.23
R200300	<b>K56G</b>	70.056.07	50.056.07
R201300	<b>K971R</b>		
R201303	<b>K970R</b>	70.970.18	50.970.18
R201307	<b>K931L</b>	70.931.12	50.931.12
R201309	<b>KG931R</b>	77.931.18	57.931.18

PART NO.	QWIKKIT	PLUSKIT	ECONO KIT
<b>ROCKWELL CONT.</b>			
R201310	<b>KG931R</b>	77.931.18	57.931.18
R201312	<b>KH931L</b>	78.931.12	58.931.12
R201314	<b>K70D</b>	70.070.04	50.070.04
R201315	<b>K961L</b>	70.961.12	50.961.12
R201318	<b>K941R</b>	70.941.18	50.941.18
R201319	<b>KG931R</b>	77.931.18	57.931.18
R201320	<b>K71D</b>	70.071.04	50.071.04
R201370	<b>K931L</b>	70.931.12	50.931.12
R201419	<b>K981R</b>	70.981.18	50.981.18
R201420	<b>KH946R</b>	78.946.18	58.946.18
R201424	<b>KH946R</b>	78.946.18	58.946.18
R201425	<b>KG931R</b>	77.931.18	57.931.18
R201426	<b>K120I</b>	70.120.09	50.120.09
R201427	<b>K141S</b>	70.141.19	50.141.19
R201470	<b>K961L</b>	70.961.12	50.961.12
R201471	<b>KG931R</b>	77.931.18	57.931.18
R201472	<b>K981R</b>	70.981.18	50.981.18
R201473	<b>K120R</b>	70.120.18	50.120.18
R201474	<b>K80R</b>	70.080.18	50.080.18
R201475	<b>K180R</b>	70.180.18	50.180.18
R201476	<b>K181R</b>	70.181.18	50.181.18
R201477	<b>KH931L</b>	78	

# KING PIN KIT INTERCHANGE

**PART NO. QWIKKIT PLUSKIT ECONO KIT**

**SPICER CONT.**

KPK1051	K71F	70.071.06	50.071.06
KPK1052	K72F	70.072.06	50.076.06
KPK1053	K942F	70.942.06	50.942.06
KPK1054	K96F	70.096.06	50.096.06
KPK1055	K941F	70.941.06	50.941.06
KPK1056	K71F	70.071.06	50.071.06
KPK1057	K76F	70.076.06	50.076.06
KPK1058	K942FA		
KPK1062	K95G	70.095.07	50.095.07
KPK1063	K95G	70.095.07	50.095.07
KPK1067	K70G	70.070.07	50.070.07
KPK1068	K80R	70.080.18	70.080.18
KPK1069	K70G	70.070.07	50.070.07
KPK1073	K55G	70.055.07	50.055.07
KPK1075	K55G	70.055.074	50.055.07
KPK1076	K310I	70.310.09	50.310.09
KPK1077	K121G	70.121.07	50.121.07
KPK1078	K971R		
KPK1080	K56G	70.056.07	50.056.07
KPK1082	K56G	70.056.07	50.056.07
KPK1083	K80G		
KPK1084	K110G		
KPK1085	K120G		
KPK1086	K981R	70.981.18	50.981.18
KPK1088	K901L	70.901.12	50.901.12
KPK1089	K109I		50.109.09
KPK1092	K970R	70.970.18	50.970.18
KPK1093	K109I		50.109.09
KPK1094	K140I	70.140.09	50.140.09
KPK1095	K108I		50.108.09
KPK1096	K139I	70.139.09	50.139.09
KPK1097	K309I	70.309.09	50.309.09
KPK1098	K981R	70.981.18	50.981.18
KPK1102	K108I		50.108.09
KPK1105	K535M		
KPK1106	K533M	70.533.13	50.533.13
KPK1108	K616M	70.616.13	50.616.13
KPK1109	K536M		
KPK1110	K125G	70.125.07	50.125.07
KPK1111	KD901R	70.901.18	50.901.18
KPK1112	KH901L	78.901.12	58.901.12
KPK1113	KH901L	78.901.12	58.901.12
KPK1114	K970R	70.970.18	50.970.18
KPK1115	K921L	70.921.12	50.921.12
KPK1116	KH931L	78.931.12	58.931.12
KPK1117	K931L	70.931.12	50.931.12
KPK1118	KG931R	77.931.18	57.931.18
KPK1119	K931L	70.931.12	50.931.12
KPK1120	KG931R	77.931.18	57.931.18
KPK1121	KH931L	78.931.12	58.931.12
KPK1122	K961L	70.961.12	50.961.12
KPK1123	K961L	70.961.12	50.961.12
KPK1124	K180R	70.180.18	50.180.18
KPK1128	K120W		
KPK1130	K126W	70.126.23	50.126.23
KPK1131	K125W	70.125.23	50.125.23
KPK1134	K140I	70.140.09	50.140.09
KPK1136	K101I	70.101.09	50.101.09
KPK1148	K121E	70.121.05	50.121.05

**SPICER SPIRAL**

KPK3001	K961L	70.961.12	50.961.12
KPK3002	K147E	70.147.05	50.147.05
KPK3003	K120I	70.120.09	50.120.09
KPK3004	K103S	70.103.19	50.103.19

**PART NO. QWIKKIT PLUSKIT ECONO KIT**

**SPICER SPIRAL CONT.**

KPK3005	K102I	70.102.09	50.102.09
KPK3006	K120E	70.120.05	50.120.05
KPK3007	KH931L	78.931.12	58.931.12
KPK3008	K80R	70.080.18	50.080.18
KPK3009	K180E	70.180.05	50.180.05
KPK3010	KG931R	77.931.18	57.931.18
KPK3011	K122E	70.122.05	50.122.05
KPK3013	K533M	70.533.13	50.533.13
KPK3016	K146E	70.146.05	50.146.05
KPK3017	K56G	70.056.07	50.056.07
KPK3021	K931L	70.931.12	50.931.12
KPK3044	K55G	70.055.07	50.055.07
KPK3056	K981R	70.981.18	50.981.18
KPK3057	K941R	70.941.18	50.941.18
KPK3059	KH946R	78.946.18	58.946.18
KPK3064	K141S	70.141.19	50.141.19

**STEERING**

SKB0793118	KG931R	77.931.18	57.931.18
SKB0893112	KH931L	78.931.12	58.931.12
SKB10209	K102I	70.102.09	50.102.09
SKB10319	K103S	70.103.19	50.103.19
SKB12001	K120A		
SKB12005	K120E	70.120.05	50.120.05
SKB12008	K120H		
SKB12009	K120I	70.120.09	50.120.09
SKB12205	K122E	70.122.05	50.122.05
SKB12523	K125W	70.125.23	50.125.23
SKB12623	K126W	70.126.23	50.126.23
SKB12723	K127W	70.127.23	50.127.23
SKB13023	K130W	70.130.23	50.130.23
SKB13108	K131H		
SKB14605	K146E	70.146.05	50.146.05
SKB14705	K147E	70.147.05	50.147.05
SKB14905	K149E		
SKB18005	K180E	70.180.05	50.180.05
SKB18118	K181R	70.181.18	50.181.18
SKB93112	K931L	70.931.12	50.931.12
SKB94118	K941R	70.941.18	50.941.18
SKB96112	K961L	70.961.12	50.961.12
SKB98118	K981R	70.981.18	50.981.18
SKS0793118	KG931R	77.931.18	57.931.18
SKS0893112	KH931L	78.931.12	58.931.12
SKS10209	K102I	70.102.09	50.102.09
SKS10319	K103S	70.103.19	50.103.19
SKS12001	K120A		
SKS12005	K120E	70.120.05	50.120.05
SKS12008	K120H		
SKS12009	K120I	70.120.09	50.120.09
SKS12105	K121E	70.121.05	50.121.05
SKS12205	K122E	70.122.05	50.122.05
SKS12523	K125W	70.125.23	50.125.23
SKS12623	K126W	70.126.23	50.126.23
SKS12723	K127W	70.127.23	50.127.23
SKS13023	K130W	70.130.23	50.130.23
SKS13108	K131H		
SKS14119	K141S	70.141.19	50.141.19
SKS14605	K146E	70.146.05	50.146.05
SKS14705	K147E	70.147.05	50.147.05
SKS14905	K149E		
SKS18005	K180E	70.180.05	50.180.05
SKS18118	K181R	70.181.18	50.181.18
SKS53313	K533M	70.533.13	50.533.13
SKS53613	K536M		
SKS61613	K616M	70.616.13	50.616.13

**PART NO. QWIKKIT PLUSKIT ECONO KIT**

**STEERING CONT.**

SKS7018	K70R	70.070.18	50.070.18
SKS8018	K80R	70.080.18	50.080.18
SKS8123	K81W		
SKS93112	K931L	70.931.12	50.931.12
SKS94118	K941R	70.941.18	50.941.18
SKS96112	K961L	70.961.12	50.961.12
SKS98118	K981R	70.981.18	50.981.18

**STEMCO KAISER**

	K101I	70.101.09	50.101.09
	K102I	70.102.09	50.102.09
	K103S	70.103.19	50.103.19
	K108I		50.108.09
	K109I		50.109.09
	K120E	70.120.05	50.120.05
	K120I	70.120.09	50.120.09
	K120R	70.120.18	50.120.18
	K121E	70.121.05	50.121.05
	K121G	70.121.07	50.121.07
	K122E	70.122.05	50.122.05
	K123E	70.123.05	50.123.05
	K125G	70.125.07	50.125.07
	K125W	70.125.23	50.125.23
	K126W	70.126.23	50.126.23
	K127W	70.127.23	50.127.23
	K130W	70.130.23	50.130.23
	K139I	70.139.09	50.139.09
	K140I	70.140.09	50.140.09
	K141S	70.141.19	50.141.19
	K146E	70.146.05	50.146.05
	K147E	70.147.05	50.147.05
	K160S	70.160.19	50.160.19
	K180E	70.180.05	50.180.05
	K180R	70.180.18	50.180.18
	K181R	70.181.18	50.181.18
	K309I	70.309.09	50.309.09
	K310I	70.310.09	50.310.09
	K50F	70.053.06	50.053.06
	K533M	70.533.13	50.533.13
	K55G	70.055.07	50.055.07
	K56G	70.056.07	50.056.07
	K616M	70.616.13	50.616.13
	K68Z	70.068.26	
	K69Z	70.069.26	
	K70D	70.070.04	50.070.04
	K70F	70.073.06	50.073.06
	K70G	70.070.07	50.070.07
	K70R	70.070.18	50.070.18
	K71D	70.071.04	50.071.04
	K71F	70.071.06	50.071.06
	K72F	70.072.06	50.072.06
	K75F	70.075.06	50.075.06
	K76F	70.076.06	50.076.06
	K80R	70.080.18	50.080.18
	K901L	70.901.12	50.901.12
	K921L	70.921.12	50.921.12
	K931L	70.931.12	50.931.12
	K941F	70.941.06	50.941.06
	K941R	70.941.18	50.941.18
	K942F	70.942.06	50.942.06
	K95F	70.095.06	50.095.06
	K95G	70.095.07	50.095.07
	K961L	70.961.12	50.961.12
	K96F	70.096.06	50.096.06
	K970R	70.970.18	50.970.18

**PART NO. QWIKKIT PLUSKIT ECONO KIT**

**STEMCO KAISER CONT.**

	K981R	70.981.18	50.981.18
	K98I	70.098.09	50.098.09
	KD901R	74.901.18	54.901.18
	KE350F	75.350.06	55.350.06
	KG931R	77.931.18	57.931.18
	KH901L	78.901.12	58.901.12
	KH931F	78.931.06	58.931.06
	KH931L	78.931.12	58.931.12
	KH946R	78.946.18	58.946.18

**THOMAS BUS**

8314171	K102I	70.102.09	50.102.09
1307	K931L	70.931.12	50.931.12
1309	KG931R	77.931.18	57.931.18
1310	KG931R	77.931.18	57.931.18
P6073300019KZ	K120A		
P6073300119KZ	K120A		

**TRAYER / ROAD LEVELER**

TK257	K98I	70.098.09	50.098.09
TK331	K51G		
TK331B	K51G		
TK336	K98I	70.098.09	50.098.09
TK406	K95G	70.095.07	50.095.07
TK422	K125G	70.125.07	50.125.07
TK443	K120W		
TK461	K50F	70.053.06	50.053.06
TK462	K70G	70.070.07	50.070.07
TK463	K51G		
TK464	K901L	70.901.12	50.901.12
TK467	K95G	70.095.07	50.095.07
TK472	K51G		
TK472B	K51G		
TK473	K70G	70.070.07	50.070.07
TK473B	K70G	70.070.07	50.070.07
TK475	K51G		
TK480	K70D	70.070.04	50.070.04
TK481	K70D	70.070.04	50.070.04
TK482	K901L	70.901.12	50.901.12
TK483	K70F	70.073.06	50.073.06
TK483B	K70F	70.073.06	50.073.06
TK490	K109I		50.109.09
TK496	KD901R	74.901.18	54.901.18
TK497	K70D	70.070.04	50.070.04
TK498	K70D	70.070.04	50.070.04
TK506	K970R	70.970.18	50.970.18
TK507	K901L	70.901.12	50.901.12
TK509	K970R	70.970.18	50.970.18
TK510	KD901R	74.901.18	54.901.18
TK512	KH901L	78.901.12	58.901.12
TK513	KH901L	78.9	

# KING PIN KIT INTERCHANGE

PART NO.	QWIKKIT	PLUSKIT	ECONO KIT
<b>TRW CONT.</b>			
K570B	K971R		
K571B	K310I	70.310.09	50.310.09
K572B	K140I	70.140.09	50.140.09
K574B	K616M	70.616.13	50.616.13
K576C	K931L	70.931.12	50.931.12
K577C	K56G	70.056.07	50.056.07
K578B	K71F	70.071.06	50.071.06
K582	KG931R	77.931.18	57.931.18
K583	KG931R	77.931.18	57.931.18
K584	K120E	70.120.05	50.120.05
K585	KH931L	78.931.12	58.931.12
K586	K121E	70.121.05	50.121.05
K587	K72F	70.072.06	50.072.06
K588	K942F	70.942.06	50.942.06
K589	K96F	70.096.06	50.096.06
K590	K941F	70.941.06	50.941.06
K591B	K180E	70.180.05	50.180.05
K592	K102I	70.102.09	50.102.09
K593	K961L	70.961.12	50.961.12
K594	K140I	70.140.09	50.140.09
K595	K108I		50.108.09
K596	K941F	70.941.06	50.941.06
K602	K120I	70.120.09	50.120.09
K602C	K120I	70.120.99	50.120.09
K603C	K141S	70.141.19	50.141.19
K606C	K942FA		
K607B	K76F	70.076.06	50.076.06
K608	K51G		
K609	K120E	70.120.05	50.120.05
K610	K121E	70.121.05	50.121.05
K611	K56G	70.056.07	50.056.07
K612B	K146F		
K617	K180E	70.180.05	50.180.05
K618C	K80G		
K619C	K110G		
K620	K120G		
K623C	K141S	70.141.19	50.141.19
K624C	K942F	70.942.06	50.942.06
K627C	K160S	70.160.19	50.160.19
K628	K122E	70.122.05	50.122.05

PART NO.	QWIKKIT	PLUSKIT	ECONO KIT
<b>TW</b>			
FKP102C	K56G	70.056.07	50.056.07
FKP105B	K941F	70.941.06	50.941.06
FKP115B	K120E	70.120.05	50.120.05
FKP39B	K70G	70.070.07	50.070.07
FKP68B	K140I	70.140.09	50.140.09
FKP77B	K139I	70.139.09	50.139.09
FKP85B	K533M	70.533.13	50.533.13
FKP86B	K121G	70.121.07	50.121.07
FKP90B	K931L	70.931.12	50.931.12
FKP94B	K616M	70.616.13	50.616.13
FKP98B	K120E	70.120.05	50.120.05

PART NO.	QWIKKIT	PLUSKIT	ECONO KIT
<b>VOLVO-WHITE</b>			
123	K125G	70.125.07	50.125.07
138	KD901R	74.901.18	54.901.18
142	KD901R	74.901.18	54.901.18
143	K70D	70.070.04	50.070.04
144	K125G	70.125.07	50.125.07
154	KD901R	74.901.18	54.901.18
155	K70D	70.070.04	50.070.04
156	K970R	70.970.18	50.970.18
157	K970R	70.970.18	50.970.18
167	K901L	70.901.12	50.901.12
168	KH901L	78.901.12	58.901.12
170	KH901L	78.901.12	58.901.12
172	K901L	70.901.12	50.901.12
195	K931L	70.931.12	50.931.12
198	KH931L	78.931.12	58.931.12
199	K921L	70.921.12	50.921.12
1300	K971R		
1307	K931L	70.931.12	50.931.12
216446	K120W		
216677	KD901R	74.901.18	54.901.18
217175	K125W	70.125.23	50.125.23
836687	K125G	70.125.07	50.125.07
857328	K125G	70.125.07	50.125.07
859552	K970R	70.970.18	50.970.18
1115275	K961L	70.961.12	50.961.12
1715442	K970R	70.970.18	50.970.18
1720728	KH901L	78.901.12	58.901.12
1739844	KH901L	78.901.12	58.901.12
20751021			50.121.08
3009155	K901L	70.901.12	50.901.12
3090266	K140V		
3090267	K122V		
3093704	K981R	70.981.18	50.981.18
3130711	K122V		
3133649	K121G	70.121.07	50.121.07
3947959	K122E	70.122.05	50.122.05
7000856	K901L	70.901.12	50.901.12
85101057	KG931R	77.931.18	57.931.18
85104370			50.121.08
85104371			50.121.08
85106184	K122E	70.122.05	50.122.05
85108338	K536M		
85125838	KH931L	78.931.12	58.931.12
02-7091941	K921L	70.921.12	50.921.12
37090-4417	KG931R	77.931.18	57.931.18
37090-5000	K931L	70.931.12	50.931.12
37090-5002	KG931R	77.931.18	57.931.18
37090-5005	K126W	70.126.23	50.126.23
37090-5015	K971R		
37090-5018	K931L	70.931.12	50.931.12
37090-5019	KG931R	77.931.18	57.931.18
37090-5022	KH931L	78.931.12	58.931.12
V1110083	KH931L	78.931.12	58.931.12
V1112400	K120E	70.120.05	50.120.05
V1112446	K120E	70.120.05	50.120.05
V1112810	K120E	70.120.05	50.120.05
V276193	K122V		

PART NO.	QWIKKIT	PLUSKIT	ECONO KIT
<b>WATSON CHALIN</b>			
SRK98	K130W	70.130.23	50.130.23
SRK102	K961L	70.961.12	50.961.12
SRK103	K941R	70.941.18	50.941.18
SRK105	KH931L	78.931.12	58.931.12
SRK112	K130W	70.130.23	50.130.23
SRK115	K81W		
SRK120	K181R	70.181.18	50.181.18

PART NO.	QWIKKIT	PLUSKIT	ECONO KIT
<b>WESTERN STAR</b>			
195	K931L	70.931.12	50.931.12
198	KH931L	78.931.12	58.931.12
1307	K931L	70.931.12	50.931.12
217175	K125W	70.125.23	50.125.23
806355	K120E	70.120.05	50.120.05
37090-5000	K931L	70.931.12	50.931.12
37090-5002	KG931R	77.931.18	57.931.18
37090-5005	K126W	70.126.23	50.126.23
37090-5015	K971R		
37090-5018	K931L	70.931.12	50.931.12
37090-5019	KG931R	77.931.18	57.931.18
37090-5022	KH931L	78.931.12	58.931.12

PART NO.	QWIKKIT	PLUSKIT	ECONO KIT
<b>WESTPORT</b>			
143698-0001	K125W	70.125.23	50.125.23
143698-0002	K126W	70.126.23	50.126.23
143698-0018	K181R	70.181.18	50.181.18
143698-0024	K95F	70.095.06	50.095.06
143698-0029	K127W	70.127.23	50.127.23
143698-0040	K72F	70.072.06	50.072.06
143698-0051	K126W	70.126.23	50.126.23
143698-0052	K127W	70.127.23	50.127.23
143698-0053	K96F	70.096.06	50.096.06
143698-0063	K127W	70.127.23	50.127.23
1637090-4405	K126W	70.126.23	50.126.23

PART NO.	QWIKKIT	PLUSKIT	ECONO KIT
<b>WORKHORSE</b>			
8003056	K50W		
8007225	K50W		
8006372	K58G	70.058.07	
8007232	K72F	70.072.06	50.072.06
8803050	K56G	70.056.07	50.056.07

# SPRING PIN INTERCHANGE

SUPPLIER	STEMCO KAISER
<b>BLUEBIRD</b>	
00051758	BSP12-17
0997056	BSP25-2
0663856	BSP25-2
1034271	BSP60-1
1353440	BSP55-1
1662774	BSP12-17

SUPPLIER	STEMCO KAISER
<b>CRANE CARRIER</b>	
243-233	BSP12-12

SUPPLIER	STEMCO KAISER
<b>DAYTON</b>	
327-106	BSP16-2
327-107	BSP2-2
327-109	BSP54-1
327-124	BSP16-2
327-128	BSP60-1
327-129	BSP35-1
327-148	BSP18-5
327-209	BSP10-8
327-211	BSP10-7
327-212	BSP12-20
327-216	BSP25-2
327-224	BSP12-13
327-225	BSP12-12
327-227	BSP59-1
327-229	BSP34-1
327-230	BSP35-1
327-237	BSP10-9
327-250	BSP25-2
327-254	BSP2-2
327-256	BSP12-21
327-290	BSP20-2
327-297	BSP67-1
327-305	BSP68-1
327-306	BSP69-1
327-331	BSP90-1
327-342	BSP31-6
327-384	BSP24-2
327-403	BSP10-8
327-434	BSP70-1
327-437	BSP46-2
327-443	BSP71-1
327-445	BSP12-12
327-446	BSP12-17
327-447	BSP12-18
327-450	BSP38-2
327-479	BSP55-1
327-480	BSP49-1
327-481	BSP38-2
327-483	BSP50-1
327-485	BSP55-1
327-487	BSP38-2
327-490	BSP79-1
327-491	BSP50-3
327-508	BSP63-1
327-516	BSP50-2
327-521	BSP75-1
327-522	BSP12-17
327-533	BSP83-1
327-737	BSP20-2

SUPPLIER	STEMCO KAISER
<b>DODGE</b>	
E-1818	BSP2-2
E-3761	BSP46-2

SUPPLIER	STEMCO KAISER
<b>EUCLID</b>	
E1817TU	BSP16-2
E1818	BSP2-2
E3715	BSP31-6
E3761	BSP46-2
E7312	BSP34-1
E7316	BSP35-1
E7318	BSP71-1

SUPPLIER	STEMCO KAISER
<b>FLAGG</b>	
B1112-50	BSP16-2
B1140-62	BSP59-1
B1144-43	BSP25-2
B1146-43	BSP18-5
B1171-50	BSP2-2
B1185-43	BSP25-2
B1197-43	BSP10-7
B1205-43	BSP12-20
B1220-55	BSP20-2
B1220-55	BSP68-1
B1221-55	BSP67-1
B1252-96	BSP10-6
B1258-62	BSP31-6
B1262-55	BSP12-20
B1268-55	BSP10-9
B1310-43	BSP10-7
B1311-43	BSP10-8
B1314-55	BSP12-21
B1318-16	BSP10-8
B1335-75	BSP12-12
B1336-75	BSP12-13
B1339-62	BSP90-1
B1354-96	BSP24-2
B1355-62	BSP59-1
B1363-59	BSP69-1
B1368-55	BSP35-1
B1369-55	BSP34-1
B1372-59	BSP70-1
B1378-50	BSP2-2
B1386-50	BSP46-2
B1389-24	BSP12-12
B1400-55	BSP71-1
B1401-75	BSP12-12
B1403-75	BSP12-17
B1407-50	BSP54-1
B1408-46	BSP38-2
B1409-46	BSP79-1
B1419-75	BSP50-1
B1420-75	BSP50-1
B1430-46	BSP44-2
B1434-55	BSP49-1
B1435-55	BSP55-1
B1438-46	BSP38-2
B1445-46	BSP38-2
B1446-59	BSP67-1
B1464-92	BSP83-1
B1479-94	BSP63-1
B1480	BSP60-1
B1488-46	BSP50-3
B1489-14	BSP12-17
B1491-96	BSP83-1
B1498-43	BSP50-2

SUPPLIER	STEMCO KAISER
<b>FORD</b>	
RB161	BSP41-1
7EQ-5780	BSP25-2
B77Z-5465-A	BSP18-5
B80H-5780-A	BSP25-2
B80H-5780-B	BSP2-2
DOHZ-5780-B	BSP12-20
DOHZ-5780-D	BSP16-2
DOHZ-5780-E	BSP10-8
DOHZ-5780-F	BSP10-7
E3HZ-5780-A	BSP46-2
E5HZ-5780A	BSP10-7
E5HZ-5780B	BSP10-8
F7HT-5A3140A	BSP50-2
TWAA-5780-A	BSP16-2

SUPPLIER	STEMCO KAISER
<b>FREIGHTLINER</b>	
16-12302-000	BSP79-1

# SPRING PIN INTERCHANGE BEARING INTERCHANGE

## SUPPLIER STEMCO KAISER

PETERBILT	
02-01846	BSP12-12
02-01847	BSP12-13

## PIERCE

1006380	BSP66-1
1006381	BSP66-2
1006382	BSP65-1
1006383	BSP65-2
1006385	BSP24-2
1006386	BSP49-1
1006387	BSP55-1
2267668	BSP24-2
2267670	BSP49-1
2267672	BSP55-1
2267673	BSP65-1
2267676	BSP65-2
2267678	BSP66-1
2267679	BSP66-2
40-0190	BSP66-1
40-0195	BSP65-1
40-4958	BSP55-1
40-6006	BSP66-2
40-6745	BSP65-2
40-6954	BSP24-2
40-8553	BSP49-1
40-9529	BSP66-1
40-9530	BSP66-2
40-9531	BSP65-1
40-9532	BSP65-2
40-9533	BSP24-2
40-9534	BSP49-1
40-9535	BSP55-1

## TW

81205	BSP12-20
81220	BSP25-2
81258	BSP31-6
81310	BSP10-7
81311	BSP10-8
81354	BSP24-2
81400	BSP71-1
81408	BSP38-2
81434	BSP49-1

## VOLVO

1075226	BSG0078-1
1075723	BSP83-1
1076334	BSP85-1
1614229	BSP85-1
3082276	BSP24-2
3974787	BSP24-2
V1614230	BSP83-1

## WESTERN STAR

37121-3412	BSP63-2
37121-3413	BSP63-1

## WHITE

04-9040450	BSP21-2
37121-0001	BSP24-2

## SUPPLIER STEMCO KAISER

T110	701.4.9
T119	701.4.14
T126	701.4.4
T1260S	701.4.34
T1370	701.4.23
T139	701.4.15
T139S	701.4.35
T149	701.4.5
T1490S	701.4.36
T163	701.4.1
T1760	701.4.18
T179SP	701.4.31
T182	701.4.2
T1822S	701.4.30
T18294S	701.4.28
T182S	701.4.27
T1880	701.4.3
T188S	701.4.25
T189	701.4.24
T1910	701.4.19
T1920	701.4.17
T1921	701.4.20
T194S	701.4.21
T195S	701.4.22
T202	701.4.29
T208	701.4.11
T208S	701.4.37
T216SP	701.4.32
528548B1	701.4.26

# SHIM PACK CROSS REFERENCE SHEET

INDIVIDUAL SHIM NUMBER	10 PACK NUMBER	THICKNESS	OUTSIDE DIAMETER	INSIDE DIAMETER	KIT REFERENCE (TOP 10)
80P1-1	SP1-1	0.005	2.87	1.63	K139I, K140I, K95F, K96F, K971R, 70.139.09, 70.140.09, 70.095.06, 70.096.06
80P1-12	SP1-12	0.005	2.50	1.33	K71F, K72F, 50.071.06, 50.072.06, 70.071.06, 70.072.06
80P1-14	SP1-14	0.005	2.62	1.65	K120E, K121E, 50.120.05, 50.121.05, 70.120.05, 70.121.05
80P1-2	SP1-2	0.005	2.81	1.87	K122E, K126W, K127W, K931L, K961L, KG931R, KH946R, 70.122.05, 70.961.12
80P1-21	SP1-21	0.005	1.94	1.20	K50W, K55G, K565G, K586, K68Z, K69Z, 50.055.07, 50.056.07, 70.055.07, 70.056.07, 70.058.07
80P1-22	SP1-22	0.005	2.24	1.39	K101I, K102I, K103S, 50.101.09, 50.102.09, 50.103.19, 70.101.09, 70.102.09, 70.103.19
80P1-23	SP1-23	0.005	3.60	2.14	K120I, K141S, K160A, K160S, K161S, 50.120.09, 50.141.19, 50.160.19, 70.120.09, 70.141.19, 70.160.19
80P1-24	SP1-24	0.005	3.00	1.90	K120H, K146E, K147E, 50.146.05, 50.147.05, 70.146.05, 70.146.05
80P1-26	SP1-26	0.005	1.61	1.32	K80G
80P1-30	SP1-30	0.005	3.75	2.27	K700T
80P1-5	SP1-5	0.005	2.50	1.50	K170G, K75F, K76F, KD901R, 50.075.06, 50.076.06, 54.901.18, 70.075.06, 70.076.06, 74.901.18
80P1-9	SP1-9	0.005	3.25	2.03	K180E, K180R, K181R, KH901L, KH931L, 50.180.05, 78.931.12, 70.180.05, 78.901.12, 78.931.12
80P2-1	SP2-1	0.010	2.00	1.31	K50F, K70D, K70F, K70G, K71D, 70.053.06, 70.073.06, 70.070.07, 70.071.04
80P2-10	SP2-10	0.010	2.50	1.33	K71F, K72F, 50.071.06, 50.072.06, 70.071.06, 70.072.06
80P2-11	SP2-11	0.010	2.62	1.65	K120E, K121E, 50.120.05, 50.121.05, 70.120.05, 70.121.05
80P2-15	SP2-15	0.010	2.50	1.81	K120R, K981R, 50.981.18, 70.981.18
80P2-17	SP2-17	0.010	1.94	1.20	K55G, K56G, K58G, K68Z, K69Z, 50.055.07, 50.056.07, 70.055.07, 70.056.07, 70.058.07
80P2-18	SP2-18	0.010	2.24	1.39	K101I, K102I, K103S, 50.101.09, 50.102.09, 50.103.19, 70.101.09, 70.102.09, 70.103.19
80P2-19	SP2-19	0.010	3.60	2.14	K120I, K140S, K160S, K161S, 50.120.09, 50.140.19, 50.160.19, 70.120.09, 70.140.19, 70.160.19
80P2-2	SP2-2	0.010	2.50	1.50	K170G, K75F, K76F, KD901R, 50.075.06, 50.076.06, 54.901.18, 70.075.06, 70.076.06, 74.901.18
80P2-20	SP2-20	0.010	3.00	1.90	K120H, K146E, K147E, 50.146.05, 50.147.05, 70.146.05, 70.146.05
80P2-21	SP2-21	0.010	2.50	1.52	K70R, K80R, K941R, 50.070.18, 50.080.18, 50.941.18, 70.070.18, 70.080.18, 70.941.18
80P2-24	SP2-24	0.010	1.95	1.25	K60R
80P2-27	SP2-27	0.010	3.75	2.27	K700T, 70.700.20
80P2-3	SP2-3	0.010	1.75	1.15	K51G
80P2-5	SP2-5	0.010	2.81	1.87	K122E, K126W, K127W, K931L, K961L, KG931R, KH946R, 70.122.05, 70.961.12
80P2-7	SP2-7	0.010	3.25	2.03	K180E, K180R, K181R, KH901L, KH931L, 50.180.05, 78.931.12, 70.180.05, 78.901.12, 78.931.12
80P2-8	SP2-8	0.010	2.00	1.15	KE350F, 5.350.06, 50.050.04, 75.300.06, 70.050.04
80P2-9	SP2-9	0.010	2.31	1.22	K95G, 50.095.07, 70.095.07
80P3-24	SP3-24	0.030	2.81	1.87	K80A, K120A, K122E, K123E, K123K, 50.122.05, 50.123.05, 70.122.05, 70.123.05
80P3-26	SP3-26	0.015	1.89	1.60	K110G, K120G
80P3-29	SP3-29	0.030	3.25	2.03	K180E, K180R, K181R, KH901L, KH931L, 50.180.05, 78.931.12, 70.180.05, 78.901.12, 78.931.12
80P3-31	SP3-31	0.030	3.00	1.90	K120H, K146E, K147E, 50.146.05, 50.147.05, 70.146.05, 70.146.05

SHIM PACK CROSS-REFERENCE SHEET

AUG 2017

01 577 0083

# QWIKKIT COMPONENTS

KIT REF.	K1011		K1021		K103S		K1081		K1091		K110G		K120A		K120E		K120G	
PART REF.	QTY	PART NO.	QTY	PART NO.	QTY	PART NO.	QTY	PART NO.	QTY	PART NO.	QTY	PART NO.	QTY	PART NO.	QTY	PART NO.	QTY	PART NO.
<b>KING PIN</b>	2	10M13-1	2	10M37-1	2	10M56-1	2	10M27-1	2	10M14-2	2	10M42-5	2	10M63-1	2	10M24-10	2	10M42-6
<b>BUSHING</b>	4	20M13-1	4	20M13-1	4	20M13-1	4	20M14-4	4	20M14-4	2	20M18-9	4	32A18-4	4	20M16-8	2	20M18-9
<b>STEEL LINER</b>																		
<b>TAPER LOCK PINS</b>	2	60M7-1	2	60M4-10	4	60M2-20	2	60M2-11	4	602.4.1			4	60M1-21	2	60M2-15		
			2	60M4-11														
			2	60M7-8														
<b>END PLATE / PLUG</b>	4	401.12.1	4	401.12.1			4	401.3.1	4	401.3.1			4	45P8-4	4	401.127.2		
<b>O-RING GASKET</b>	4	93P1-6	4	93P1-6	4	92P1-28	4	92P1-8	4	92P1-8	2	41P10-2	4	92P1-37	4	92P1-11	2	41P10-2
<b>BUSHING SEAL</b>	4	91P1-14	4	91P1-14	4	91P1-14	4	91P1-19			2	91P5-2	4	91P1-47	4	91P1-25	2	91P5-2
											2	91P6-2					2	91P6-2
<b>BEARING</b>	2	701.4.35	2	701.4.35	2	701.4.35	2	701.4.5	2	701.4.5	2	70P4-4A	1	701.4.31	2	701.4.19	2	70P4-4A
											2	70P4-4B	1	701.7.1			2	70P4-4B
<b>BEARING SEAL</b>							2	91P2-15										
<b>SHIM</b>	5	80P1-22	5	80P1-22	5	80P1-22	7	80P1-1	7	80P1-1	6	80P3-26	6	80P2-5	5	80P1-14	6	80P3-26
	5	80P2-18	5	80P2-18	5	80P2-18							12	80P3-24	5	80P2-11		
<b>CAP SCREW</b>	8	5/16-18X.6	8	5/16-18X.6			12	5/16-18X.7	12	5/16-18X.7					12	5/16-18X1		
<b>NUT</b>	2	50P19-2	2	50P19-2	4	50P19-2	2	50P19-3					4	50P19-1	2	50P19-3		
<b>LOCK WASHER</b>	8	5/16	8	5/16			12	5/16	12	5/16					12	5/16		
<b>FELT WASHER</b>																		
<b>EXPANSION PLUG</b>																		
<b>RELIEF FITTING</b>																		
<b>COTTER PIN</b>																		
<b>LOCK RING</b>													4	100P1-5				
<b>CASTLE NUT</b>											2	50P17-1					2	50P17-1

KIT REF.	K123E		K123K		K125G		K125W		K126W		K127W		K130R		K130W		K131H		
PART REF.	QTY	PART NO.	QTY	PART NO.	QTY	PART NO.	QTY	PART NO.	QTY	PART NO.	QTY	PART NO.	QTY	PART NO.	QTY	PART NO.	QTY	PART NO.	
<b>KING PIN</b>	2	10M55-2	2	10M35-5	2	9M16-6	2	10M18-2	2	10M18-2	2	10M18-2	2	10M33-5	2	10M21-3	2	10M18-8	
<b>BUSHING</b>	4	20M19-9	4	20M19-9	4	20M16-7	2	20M18-1	2	20M18-1	2	20M18-1	2	20M19-9	4	20M20-1	4	20M18-10	
							2	20M18-2	2	20M18-2	2	20M18-2	2	20M19-11					
<b>STEEL LINER</b>																			
<b>TAPER LOCK PINS</b>	2	60M1-16	2	60M1-23					2	60M2-8	2	60M2-8	2	60M1-7	2	60M1-1	2	60M1-1	
	2	60M1-17											2	60M1-8					
<b>END PLATE / PLUG</b>	4	45P6-1	4	45P6-1	2	40P16	4	401.20.1	4	401.20.1	4	45P2-3	2	45P2-3	4	45P2-3	4	45P8-1	
													2	45P17-1					
<b>O-RING GASKET</b>	4	93P1-12			2	41P4-1	4	92P1-4	4	92P1-4								4	92P1-17
<b>BUSHING SEAL</b>	4	91P1-29	4	91P1-29	4	91P3-1	4	91P1-44	4	91P1-44	4	91P1-44	4	91P1-29	4	91P1-29	4	91P1-44	
<b>BEARING</b>	2	701.4.28	2	701.4.2	2	701.4.1	2	701.4.25	2	701.4.17	2	701.4.20	2	701.4.27	2	701.4.27	2	701.4.30	
<b>BEARING SEAL</b>													2	91P2-11					
<b>SHIM</b>	3	80P1-2	3	80P1-2	5	80P3-3	7	80P1-2	7	80P1-2	7	80P1-2	7	80P1-2	4	80P1-19	4	80P1-19	
	5	80P2-5	5	80P2-5	2	80P3-4	5	80P2-5	5	80P2-5	5	80P2-5	5	80P2-5	2	80P2-15	4	80P2-15	
	2	80P3-24	2	80P3-24	2	80P3-5							2	80P3-33	4	80P3-33			
<b>CAP SCREW</b>											6	5/16-18X.5	12	1/4-20X1/2	12	1/4-20X1/2			
<b>NUT</b>	4	50P19-2	2	50P19-2									2	50P19-1	2	50P19-1	2	50P19-1	
<b>LOCK WASHER</b>													6	5/16	12	1/4			
<b>FELT WASHER</b>																			
<b>EXPANSION PLUG</b>																			
<b>RELIEF FITTING</b>																			
<b>COTTER PIN</b>																			
<b>LOCK RING</b>																			
<b>CASTLE NUT</b>																			

KIT REF.	K120H		K120I		K120N		K120R		K120W		K121E		K121G		K122E		K122V		
PART REF.	QTY	PART NO.	QTY	PART NO.	QTY	PART NO.	QTY	PART NO.	QTY	PART NO.	QTY	PART NO.	QTY	PART NO.	QTY	PART NO.	QTY	PART NO.	
<b>KING PIN</b>	2	10M51-2	2	10M38-2	2	10M54-1	2	10M33-3	2	10M18-1	2	10M24-10	2	10M21-8	2	10M35-3	2	9M12-1	
<b>BUSHING</b>	4	20M18-10	4	20M21-11	2	32A18-1	4	20M20-1	2	20M18-1	4	20M16-8	2	20M19-7	4	20M19-9	2	20M24-2	
					2	32A18-2			2	20M18-2			2	20M19-8					
<b>STEEL LINER</b>																		2	31M18-1
<b>TAPER LOCK PINS</b>			2	60M2-19			2	60M1-1	2	60M2-1	2	60M2-15	2	60M4-7	2	60M1-9			
			2	60M2-20			2	60M1-8					2	60M4-8					
<b>END PLATE / PLUG</b>	4	45P8-1			4	401.140.1	4	401.128.1	4	401.20.1	4	401.127.2	4	401.128.1	4	45P6-1			
<b>O-RING GASKET</b>	4	92P1-17	4	92P1-20	4	92P1-27	4	92P1-4	4	92P1-4	4	92P1-11	4	92P1-4	4	93P1-12	2	92P1-24	
																	2	92P1-25	
<b>BUSHING SEAL</b>	4	91P1-44	4	91P1-32			4	91P1-29			4	91P1-25			4	91P1-29	2	91P7-1	
																	2	91P8-1	
<b>BEARING</b>	2	701.4.30	2	701.4.21	2	701.4.26	2	701.4.27	2	701.4.25	2	70P2-13	2	701.4.18	2	701.4.2	2	70P4-3	
<b>BEARING SEAL</b>													2	91P2-9/10					
<b>SHIM</b>	26	80P2-20	6	80P1-23	4	80P1-9	5	80P1-19	7	80P1-2	5	80P1-14	5	80P1-2	3	80P1-2	2	80P3-25	
			6	80P2-19	4	80P2-7	3	80P2-15			5	80P2-11	5	80P2-5	5	80P2-5	4	80P3-26	
			4	80P3-30	6	80P3-32	4	80P3-33							2	80P3-24	2	80P3-28	
<b>CAP SCREW</b>	4	5/8-11X1.25	12	5/16-18X1			12	5/16-18X1	12	1/4-20X1/2	12	5/16-18X1	12	5/16-18X.7					
<b>NUT</b>			4	50P19-2			4	50P19-1	2	50P19-1	2	50P19-3			2	50P19-1			
<b>LOCK WASHER</b>			12	5/16			12	5/16	12	1/4	12	5/16	12	5/16					
<b>FELT WASHER</b>																			
<b>EXPANSION PLUG</b>																			
<b>RELIEF FITTING</b>					4	90P3-1			4	90P1-1			4	90P1-1					
<b>COTTER PIN</b>																		2	102P16-3
<b>LOCK RING</b>	4	103P1-1			4	100P1-9							2	100P1-7					
<b>CASTLE NUT</b>																			

K
---



# QWIKKIT COMPONENTS

KIT REF.	K70G		K70R		K71D		K71F		K72F		K75F		K75M		K76F		K80A	
PART REF.	QTY	PART NO.	QTY	PART NO.	QTY	PART NO.	QTY	PART NO.	QTY	PART NO.	QTY	PART NO.	QTY	PART NO.	QTY	PART NO.	QTY	PART NO.
<b>KING PIN</b>	2	10M12-1	2	10M52-3	2	10M2-1	2	10M13-6	2	10M37-4	2	10M25-1	2	10M13-7	2	10M25-1	2	10M63-2
<b>BUSHING</b>	4	20M12-1	4	20M15-7	4	20M2-1	4	20M13-4	4	20M13-7	4	20M14-6	4	32A16-12	4	20M14-6	4	32A18-5
<b>STEEL LINER</b>																		
<b>TAPER LOCK PINS</b>	2	60M3-1	2	60M1-14	4	602.4.1	2	60M2-17	2	60M1-10	2	60M1-1	2	60P6-1	2	60M1-1	4	60M1-21
			2	60M1-7					2	60M1-11	2	60M1-2			2	60M1-2		
<b>END PLATE / PLUG</b>	4	401.12.2			4	401.143.1	4	45P2-4	4	45P2-4	2	401.128.1	4	401.138.1	4	45P2-5	4	45P8-4
<b>O-RING GASKET</b>	4	41P3-1			4	92P1-16					2	92P1-4	4	92P1-23			4	92P1-37
<b>BUSHING SEAL</b>			4	91P1-41	4	91P1-43	4	91P1-35	4	91P1-35	4	91P1-16	4	91P1-37	4	91P1-16	4	91P1-47
<b>BEARING</b>	2	701.4.4	2	701.4.5	2	701.4.34	2	70P2-15	2	701.4.23	2	701.4.5	2	70P2-14	2	701.4.5	1	701.4.31
																	1	701.7.1
<b>BEARING SEAL</b>			2	91P2-15									2	91P2-14				
<b>SHIM</b>	5	80P1-4	5	80P1-25	5	80P1-4	5	80P1-12	5	80P2-10	5	80P1-5			5	80P1-5	6	80P2-5
	5	80P2-1	5	80P2-21	5	80P2-1	5	80P2-10			5	80P2-2			5	80P2-2	12	80P3-24
<b>CAP SCREW</b>	8	1/4-28X1/2			8	5/16-18X3/4					6	5/16-18X3/4						
<b>NUT</b>	2	50P19-2	4	50P19-1			2	50P19-1	4	50P19-1	4	50P19-1	2	M10X1.5	4	50P19-1	4	50P19-1
<b>LOCK WASHER</b>	8	1/4			8	5/16					6	5/16						
	2	3/8																
<b>FELT WASHER</b>																		
<b>EXPANSION PLUG</b>											2	45P1-11						
<b>RELIEF FITTING</b>	4	90P1-1									2	90P1-1						
<b>COTTER PIN</b>																		
<b>LOCK RING</b>											2	100P1-3	4	100P1-3			4	100P1-5
<b>CASTLE NUT</b>																		

KIT REF.	K942F		K942FA		K95F		K95G		K961L		K96F		K970R		K971R		K981R		
PART REF.	QTY	PART NO.	QTY	PART NO.	QTY	PART NO.	QTY	PART NO.	QTY	PART NO.	QTY	PART NO.	QTY	PART NO.	QTY	PART NO.	QTY	PART NO.	
<b>KING PIN</b>	2	10M33-2	2	10M33-2	2	10M26-1	2	9M16-7	2	10M21-3	2	10M26-1	2	10M16-5	2	10M16-7	2	10M21-12	
<b>BUSHING</b>	4	20M20-1	4	20M20-1	4	20M16-7	2	20M14-1	4	20M20-1	4	20M16-7	4	20M16-7	4	20M16-7	4	20M19-9	
							2	20M14-2											
<b>STEEL LINER</b>																			
<b>TAPER LOCK PINS</b>	2	60M1-1	2	60M1-1	2	60M1-1			2	60M1-7	2	60M1-1	4	602.4.1	4	602.4.1	2	60M1-7	
	2	60M1-2	2	60M1-2	2	60M1-2			2	60M1-8	2	60M1-2					2	60M1-8	
<b>END PLATE / PLUG</b>	4	45P2-3	4	45P2-3	2	401.128.1	2	40P16	4	401.128.1	4	45P2-5	2	40M123-1	4	401.128.1	4	45P2-3	
<b>O-RING GASKET</b>					2	92P1-4	2	41P4-1	4	92P1-4			2	92P1-8	4	92P1-4			
<b>BUSHING SEAL</b>	4	91P1-29	4	91P1-29	4	91P3-1			4	91P1-29	4	91P3-1	4	91P3-1	4	91P3-1	4	91P1-29	
<b>BEARING</b>	2	701.4.2	2	701.4.20	2	701.4.1	2	701.4.5	2	701.4.27	2	701.4.1	2	701.4.1	2	701.4.1	2	701.4.27	
<b>BEARING SEAL</b>																	2	91P2-7	
<b>SHIM</b>	9	80P1-2	9	80P1-2	9	80P1-1	9	80P2-9	5	80P1-2	9	80P1-1	13	80P1-1	7	80P1-1	5	80P1-19	
	7	80P2-5	7	80P2-5			2	80P3-7	8	80P2-5							5	80P2-15	
							2	80P3-9											
<b>CAP SCREW</b>					6	5/16-18X3/4	6	1/4-28X1/2	12	5/16-18X3/4			4	5/16-18X3/4	12	5/16-18X3/4			
<b>NUT</b>	4	50P19-1	4	50P19-1	4	50P19-1			4	50P19-1	4	50P19-1						4	50P19-1
<b>LOCK WASHER</b>					6	5/16	6	1/4	12	5/16			4	5/16	12	5/16			
<b>FELT WASHER</b>																			
<b>EXPANSION PLUG</b>																			
<b>RELIEF FITTING</b>															2	45P1-8			
															2	90P1-3			
<b>COTTER PIN</b>																			
<b>LOCK RING</b>																			
<b>CASTLE NUT</b>																			

KIT REF.	K80G		K80R		K81W		K901L		K921L		K931L		K941F		K941FA		K941R		
PART REF.	QTY	PART NO.	QTY	PART NO.	QTY	PART NO.	QTY	PART NO.	QTY	PART NO.	QTY	PART NO.	QTY	PART NO.	QTY	PART NO.	QTY	PART NO.	
<b>KING PIN</b>	2	10M42-4	2	10M52-2	2	10M52-1	2	10M21-1	2	10M21-2	2	10M21-3	2	10M33-2	2	10M33-2	2	10M52-1	
<b>BUSHING</b>	2	20M16-11	4	20M15-7	4	20M15-5	4	20M19-5	4	20M20-1	4	20M20-1	4	20M20-1	4	20M20-1	4	20M15-5	
<b>STEEL LINER</b>																			
<b>TAPER LOCK PINS</b>			2	60M1-14	2	60M1-7	2	60M7-3	2	60M7-3	2	60M1-1	2	60M1-1	2	60M1-1	2	60M1-7	
			2	60M1-7			2	60M7-4	2	60M7-4	2	60M1-2	2	60M1-2	2	60M1-2	2	60M1-14	
<b>END PLATE / PLUG</b>					4	45P2-5	2	401.128.1	4	401.128.1	4	401.128.1	4	401.128.1	4	401.128.1	4	401.139.1	
<b>O-RING GASKET</b>	2	41P10-1			4	92P1-4	4	92P1-4	4	92P1-4	4	92P1-4	4	92P1-4	4	92P1-4	4	92P1-26	
<b>BUSHING SEAL</b>	2	91P5-1	4	91P1-41	4	91P1-41	4	91P1-29	4	91P1-6	4	91P1-29	4	91P1-29	4	91P1-29	4	91P1-41	
	2	91P6-1																	
<b>BEARING</b>	2	70P4-2A	2	701.4.5	2	701.4.5	2	701.4.2	2	701.4.27	2	701.4.27	2	701.4.2	2	701.4.20	2	701.4.5	
	2	70P4-2B																	
<b>BEARING SEAL</b>			2	91P2-15	2	91P2-15												2	91P2-15
<b>SHIM</b>	8	80P1-26	5	80P1-25	2	80P1-25	5	80P1-2	5	80P1-2	5	80P1-2	9	80P1-2	9	80P1-2	5	80P2-21	
	4	80P2-22	5	80P2-21	6	80P2-21	8	80P2-5	8	80P2-5	8	80P2-5	9	80P2-5	7	80P2-5			
<b>CAP SCREW</b>							6	5/16-18X3/4	12	5/16-18X3/4	12	5/16-18X3/4	12	5/16-18X3/4	12	5/16-18X3/4	12	5/16-18X1	
<b>NUT</b>			4	50P19-1	2	50P19-1	4	50P19-2	4	50P19-2	4	50P19-1	4	50P19-1	4	50P19-1	4	50P19-1	
<b>LOCK WASHER</b>					6	5/16	12	5/16	12	5/16	12	5/16	12	5/16	12	5/16	12	5/16	
<b>FELT WASHER</b>																			
<b>EXPANSION PLUG</b>							2	45P1-9											
<b>RELIEF FITTING</b>							2	90P1-1											
<b>COTTER PIN</b>																			
<b>LOCK RING</b>							2	100P1-1											
<b>CASTLE NUT</b>	2	50P17-1																	

KIT REF.	K981		KD901R		KE350F		KG931R		KH901L		KH931F		KH931L		KH946R	
PART REF.	QTY	PART NO.	QTY	PART NO.	QTY	PART NO.	QTY	PART NO.	QTY	PART NO.	QTY	PART NO.	QTY	PART NO.	QTY	PART NO.
<b>KING PIN</b>	2	10M12-3	2	10M14-1	2	10M10-3	2	10M21-3	2	10M22-1	2	10M22-2	2	10M22-2	2	10M21-14
<b>BUSHING</b>	4	20M12-3	4	20M14-6	4</											

# PLUSKIT COMPONENTS

KIT REF.	70.053.06		70.055.07		70.056.07		70.058.07		70.068.26		70.069.26		70.070.04		70.070.07		70.070.18	
PART REF.	QTY	PART NO.	QTY	PART NO.	QTY	PART NO.	QTY	PART NO.	QTY	PART NO.	QTY	PART NO.	QTY	PART NO.	QTY	PART NO.	QTY	PART NO.
KING PIN	2	105.50.3	2	105.11.10	2	105.11.10	2	105.11.10	2	105.58.1	2	105.58.1	2	105.2.1	2	105.12.1	2	105.52.3
BUSHING	4	202.2.3	4	202.11.7	4	202.11.10	4	202.11.10	4	202.11.12	4	202.11.12	4	202.2.1	4	202.12.1	4	202.15.7
STEEL LINER																		
TAPER LOCK PINS	2	60M2-3	2	60M1-15	2	60M1-15	2	60M1-15	2	60M2-23	2	60M2-23	4	602.4.1	2	60M3-1	2	60M1-14 2 60M1-7
END PLATE / PLUG							4	401.141.1	2	45P9-1	2	45P9-1						
O-RING GASKET	4	92P1-19	4	41P3-6	4	41P3-6	4	41P3-6	2	92P1-29	2	92P1-29	2	41P3-4	4	41P3-1		
BUSHING SEAL			4	91P1-45	4	91P1-42	4	91P1-42	2	91P9-1	2	91P9-1						4 91P1-41
BEARING	2	701.4.4	2	701.4.14	2	701.4.14	2	701.4.14	2	70P2-16	1	70P2-16	2	701.4.4	2	701.4.4		
BEARING SEAL										1	70P2-17							2 91P2-15
SHIM	5	80P1-4	7	80P1-21	7	80P1-21	7	80P1-21	5	80P1-21	5	80P1-21	5	80P1-4	5	80P1-4	5	80P1-25
	5	80P2-1	5	80P2-17	5	80P2-17	5	80P2-17	5	80P2-17	5	80P2-17	5	80P2-1	5	80P2-1	5	80P2-21
CAP SCREW							12	1/4-28X5/8	2	5/16-18X5/8	2	5/16-18X5/8	4	5/16-18X3/4				
NUT	2	50P19-1	2	50P19-2	2	50P19-2	2	50P19-2	2	50P19-2	2	50P19-2			2	50P19-2	4	50P19-1
LOCK WASHER							12	1/4	2	5/16 FLAT	2	5/16 FLAT	4	5/16				
FELT WASHER																		
EXPANSION PLUG													2	45P1-6				
RELIEF FITTING													2	90P1-3				
COTTER PIN																		
LOCK RING													2	100P1-4				
CASTLE NUT																		

KIT REF.	70.096.06		70.098.09		70.101.09		70.102.09		70.103.19		70.120.05		70.120.09		70.120.18		70.120.99	
PART REF.	QTY	PART NO.	QTY	PART NO.	QTY	PART NO.	QTY	PART NO.	QTY	PART NO.	QTY	PART NO.	QTY	PART NO.	QTY	PART NO.	QTY	PART NO.
KING PIN	2	105.26.1	2	105.12.3	2	105.13.1	2	105.37.1	2	105.56.1	2	105.24.10	2	105.38.2	2	105.33.3	2	105.38.2
BUSHING	4	202.16.7	4	202.12.3	4	202.13.1	4	202.13.1	4	202.13.1	4	202.16.9	4	202.21.11	4	202.20.1	4	201.21.13
STEEL LINER																		
TAPER LOCK PINS	2	60M1-1	2	60M7-1	2	60M7-1	2	60M4-10	4	60M2-20	2	60M2-15	2	60M2-19	2	60M1-1	2	60M2-19
	2	60M1-2					2	60M4-11			2	60M2-20	2	60M1-8	2	60M1-8	2	60M2-20
END PLATE / PLUG	4	45P2-5									4	401.129.1			4	401.128.1		
O-RING GASKET			4	41P3-3	4	92P1-16	4	92P1-16	4	92P1-28	4	41P5-2	4	92P1-20	4	92P1-4	4	92P1-20
BUSHING SEAL	4	91P3-1			4	91P1-14	4	91P1-14	4	91P1-14	4	91P1-25	4	91P1-32	4	91P1-29	4	91P1-32
BEARING	2	701.4.1	2	701.4.4	2	701.4.35	2	701.4.35	2	701.4.35	2	701.4.19	2	701.4.21	2	701.4.27	2	701.4.21
BEARING SEAL																		
SHIM	9	80P1-1	5	80P1-4	4	80P1-22	5	80P1-22	5	80P1-22	5	80P1-14	6	80P1-23	5	80P1-19	6	80P1-23
			5	80P2-1	4	80P2-18	5	80P2-18	5	80P2-18	5	80P2-11	6	80P2-19	3	80P2-15	6	80P2-19
													4	80P3-30	4	80P3-33	4	80P3-30
CAP SCREW											12	5/16-18X1	12	5/16-18X1	12	5/16-18X1	12	5/16-18X1
NUT	4	50P19-1	2	50P19-2	2	50P19-2	2	50P19-2	4	50P19-2	2	50P19-3	4	50P19-2	4	50P19-1	4	50P19-2
LOCK WASHER											12	5/16	12	5/16	12	5/16	12	5/16
FELT WASHER																		
EXPANSION PLUG																		
RELIEF FITTING																		
COTTER PIN																		
LOCK RING																		
CASTLE NUT																		

KIT REF.	70.071.04		70.071.06		70.072.06		70.073.06		70.075.06		70.076.06		70.080.18		70.095.06		70.095.07	
PART REF.	QTY	PART NO.	QTY	PART NO.	QTY	PART NO.	QTY	PART NO.	QTY	PART NO.	QTY	PART NO.	QTY	PART NO.	QTY	PART NO.	QTY	PART NO.
KING PIN	2	105.2.1	2	105.13.6	2	105.37.4	2	105.50.2	2	105.25.1	2	105.25.1	2	105.52.2	2	105.26.1	2	95.16.7
BUSHING	4	202.2.1	4	202.13.4	4	202.13.7	4	202.2.7	4	202.14.6	4	202.14.6	4	202.15.7	4	202.16.7	2	202.14.1
																	2	202.14.2
STEEL LINER																		2 312.16.4
TAPER LOCK PINS	4	602.4.1	2	60M2-17	2	60M1-10	2	60M2-3	2	60M1-1	2	60M1-1	2	60M1-14	2	60M1-1		
END PLATE / PLUG	4	401.143.1	4	45P2-4	4	45P2-4												
O-RING GASKET	4	92P1-16					4	92P1-19	2	41P7-1				2	41P7-1	2	41P4-1	
BUSHING SEAL	4	91P1-43	4	91P1-35	4	91P1-35			4	91P1-16	4	91P1-16	4	91P1-41	4	91P3-1		
BEARING	2	701.4.34	2	70P2-15	2	701.4.23	2	701.4.4	2	701.4.5	2	701.4.5	2	701.4.5	2	701.4.1	2	701.4.5
BEARING SEAL													2	91P2-15				
SHIM	5	80P1-4	5	80P1-12	5	80P2-10	5	80P1-4	5	80P1-5	5	80P1-5	5	80P1-25	9	80P1-1	9	80P2-9
	5	80P2-1	5	80P2-10			5	80P2-1	5	80P2-2	5	80P2-2	5	80P2-21			2	80P3-7
																	2	80P3-9
CAP SCREW	8	5/16-18X3/4																
NUT			2	50P19-1	4	50P19-1	2	50P19-1	4	50P19-1	4	50P19-1	4	50P19-1	4	50P19-1		
LOCK WASHER	8	5/16																
FELT WASHER																		
EXPANSION PLUG									2	45P1-11				2	45P1-8	2	45P1-11	
RELIEF FITTING	2	90P1-3																
COTTER PIN																		2 102P16-1
LOCK RING														2	100P1-3	2	100P1-3	
CASTLE NUT																		2 50P14-3

KIT REF.	70.121.05		70.121.07		70.122.05		70.122.95		70.123.05		70.125.07		70.125.23		70.126.23		70.127.23		
PART REF.	QTY	PART NO.	QTY	PART NO.	QTY	PART NO.	QTY	PART NO.	QTY	PART NO.	QTY	PART NO.	QTY	PART NO.	QTY	PART NO.	QTY	PART NO.	
KING PIN	2	105.24.10	2	105.21.8	2	105.35.3	2	105.35.3	2	105.55.2	2	95.16.6	2	105.18.2	2	105.18.2	2	105.18.2	
BUSHING	4	202.16.9	4	202.19.8	4	202.19.10	4	202.19.9	4	202.19.10	4	202.16.7	4	202.18.1	4	202.18.1	4	202.18.1	
STEEL LINER												2	312.16.2						
TAPER LOCK PINS	2	60M2-15	2	60M4-7	2	60M1-9	2	60M1-9	2	60M1-16				2	60M2-8	2	60M2-8	2	60M2-8
			2	60M4-8					2	60M1-17									
END PLATE / PLUG	4	401.129.1	4	401.128.1	4	45P6-1	4	45P6-1	4	45P6-1	</								

# PLUSKIT COMPONENTS

KIT REF.	70.130.23		70.139.09		70.140.09		70.141.19		70.146.05		70.147.05		70.160.19		70.180.05		70.180.18		
PART REF.	QTY	PART NO.	QTY	PART NO.	QTY	PART NO.	QTY	PART NO.	QTY	PART NO.	QTY	PART NO.	QTY	PART NO.	QTY	PART NO.	QTY	PART NO.	
<b>KING PIN</b>	2	105.21.3	2	105.24.1	2	105.16.13	2	105.38.6	2	105.35.2	2	105.55.1	2	105.38.4	2	105.35.1	2	105.22.5	
<b>BUSHING</b>	4	202.20.1	4	202.17.1	4	202.17.1	4	202.21.10	4	202.18.8	4	202.18.8	4	202.21.10	4	202.18.4	4	202.21.2	
<b>STEEL LINER</b>																			
<b>TAPER LOCK PINS</b>	2	60M1-1	2	60M2-11	4	602.4.1	4	60M2-19	2	60M1-9	2	60M1-16	2	60M1-12	2	60M2-18	2	60M1-1	
							2	60M1-17			2	60M1-17	2	60M1-13			2	60M1-8	
<b>END PLATE / PLUG</b>	4	45P2-3									4	45P6-1							
<b>O-RING GASKET</b>			4	92P1-15	4	92P1-15	4	92P1-20	4	93P1-12	4	93P1-12	4	92P1-21	4	41P11-1	4	41P4-2	
							4	92P1-21											
<b>BUSHING SEAL</b>	4	91P1-29	4	91P3-1	4	91P3-1	4	91P1-34	4	91P1-36	4	91P1-36	4	91P1-34	4	91P1-36	4	91P1-15	
<b>BEARING</b>	2	701.4.27	2	701.4.1	2	701.4.1	2	701.4.37	2	701.4.24	2	701.4.25	2	701.4.37	2	701.4.24	2	701.4.37	
<b>BEARING SEAL</b>			2	91P2-2	2	91P2-2													
<b>SHIM</b>	4	80P1-19	7	80P1-1	7	80P1-1	3	80P1-23	3	80P1-24	3	80P1-24	3	80P1-23	3	80P1-9	3	80P1-9	
	4	80P2-15	2	80P3-13	2	80P3-13	3	80P2-19	5	80P2-20	5	80P2-20	3	80P2-19	3	80P2-7	3	80P2-7	
	4	80P3-33					2	80P3-30	2	80P3-31	2	80P3-31	2	80P3-30	2	80P3-29	2	80P3-29	
																2	80P3-34	2	80P3-34
<b>CAP SCREW</b>														16	5/16-18X1	12	5/16-18 X 1		
<b>NUT</b>	2	50P19-1	2	50P19-3			4	50P19-2	2	50P19-3	4	50P19-2	4	50P19-2	2	50P19-3	4	50P19-1	
<b>LOCK WASHER</b>														16	5/16	12	5/16		
<b>FELT WASHER</b>																			
<b>EXPANSION PLUG</b>																			
<b>RELIEF FITTING</b>																			
<b>COTTER PIN</b>																			
<b>LOCK RING</b>																			
<b>CASTLE NUT</b>																			

KIT REF.	70.931.12		70.941.06		70.941.18		70.942.06		70.961.12		70.970.18		70.981.18		74.901.18		75.350.06		
PART REF.	QTY	PART NO.	QTY	PART NO.	QTY	PART NO.	QTY	PART NO.	QTY	PART NO.	QTY	PART NO.	QTY	PART NO.	QTY	PART NO.	QTY	PART NO.	
<b>KING PIN</b>	2	105.21.3	2	105.33.2	2	105.52.1	2	105.33.2	2	105.21.3	2	105.16.5	2	105.21.12	2	105.14.1	2	105.10.2	
<b>BUSHING</b>	4	202.20.1	4	202.15.7	4	202.15.7	4	202.19.5	4	202.20.1	4	202.16.7	4	202.19.10	4	202.14.6	4	202.5.1	
<b>STEEL LINER</b>																			
<b>TAPER LOCK PINS</b>	2	60M1-1	2	60M1-1	2	60M1-7	2	60M1-1	2	60M1-7	4	602.4.1	2	60M1-7	4	602.4.1	2	60M2-3	
	2	60M1-2	2	60M1-2	2	60M1-14	2	60M1-2	2	60M1-8			2	60M1-8					
<b>END PLATE / PLUG</b>					4	401.139.1	4	45P2-3					4	45P2-3				4	45P2-2
<b>O-RING GASKET</b>	2	41P7-1	4	41P7-1	4	92P1-26			4	41P7-1	2	41P3-4			2	41P7-1			
<b>BUSHING SEAL</b>	4	91P1-29	4	91P1-29	4	91P1-41	4	91P1-29	4	91P1-29			4	91P1-29			4	91P1-23	
<b>BEARING</b>	2	701.4.27	2	701.4.2	2	701.4.5	2	701.4.2	2	701.4.27	2	701.4.1	2	701.4.27	2	701.4.5	2	70P2-3	
<b>BEARING SEAL</b>					2	91P2-15													
<b>SHIM</b>	5	80P1-2	5	80P1-2	5	80P2-21	9	80P1-2	5	80P1-2	13	80P1-1	5	80P1-19	5	80P1-5	5	80P1-10	
	8	80P2-5	8	80P2-5			9	80P2-5	8	80P2-5			5	80P2-15	5	80P2-2	5	80P2-8	
<b>CAP SCREW</b>					12	5/16-18X1													
<b>NUT</b>	4	50P19-1	4	50P19-1	4	50P19-1	4	50P19-1	4	50P19-1			4	50P19-1				2	50P19-1
<b>LOCK WASHER</b>					12	5/16													
<b>FELT WASHER</b>																			
<b>EXPANSION PLUG</b>												2	45P1-8			2	45P1-11		
<b>RELIEF FITTING</b>																			
<b>COTTER PIN</b>																			
<b>LOCK RING</b>												2	100P1-2			2	100P1-3		
<b>CASTLE NUT</b>																			

KIT REF.	70.181.18		70.230.07		70.309.09		70.310.09		70.533.13		70.616.13		70.700.20		70.901.12		70.921.12	
PART REF.	QTY	PART NO.	QTY	PART NO.	QTY	PART NO.	QTY	PART NO.	QTY	PART NO.	QTY	PART NO.	QTY	PART NO.	QTY	PART NO.	QTY	PART NO.
<b>KING PIN</b>	2	105.22.2	2	105.35.6	2	105.24.2	2	105.16.12	2	95.15.3	2	95.18.2	1	105.60.1	2	105.21.1	2	105.21.2
<b>BUSHING</b>	4	202.21.2	2	202.27.2	4	202.17.1	4	202.17.1	2	202.16.3	2	201.23.1	4	202.27.1	4	202.19.5	4	202.20.1
			2	202.27.3														
<b>STEEL LINER</b>																		
<b>TAPER LOCK PINS</b>	2	60M1-4			2	60M2-11	4	602.4.1					4	60M2-27	2	60M7-3	2	60M7-3
	2	60M1-8													2	60M7-4	2	60M7-4
<b>END PLATE / PLUG</b>	4	401.128.2	4	401.146.1					2	45P10-2	2	45P10-1	4	401.145.1				
<b>O-RING GASKET</b>	4	92P1-9	4	92P1-41	4	92P1-15	4	92P1-15	2	92P1-30	2	92P1-30	4	92P1-32	2	41P7-1	4	41P7-1
			2	92P1-42									4	92P1-39				
<b>BUSHING SEAL</b>	4	91P1-15			4	91P3-1	4	91P3-1	2	91P1-11	2	91P1-21	4	91P1-29	4	91P1-6		
									2	91P1-12	2	91P1-22						
<b>BEARING</b>	2	701.4.37	2	70P7-1	2	701.4.1	2	701.4.1	2	70P2-1	2	70P2-8	2	70P6-1	2	701.4.2	2	701.4.27
									2	70P3-2	2	70P3-3						
<b>BEARING SEAL</b>					2	91P2-2	2	91P2-2										
<b>SHIM</b>	3	80P1-9			7	80P1-1	11	80P1-1					4	80P1-30	5	80P1-2	5	80P1-2
	3	80P2-7					12	80P3-13					10	80P2-27	8	80P2-5	8	80P2-5
	2	80P3-29	2	80P3-53														
	2	80P3-34																
<b>CAP SCREW</b>	12	5/16-18 X 1	12	5/16-24 X 3/4									2	3/8-16 X 1-1/4				
<b>NUT</b>	4	50P19-1			2	50P19-3							4	50P19-1	4	50P19-2	4	50P19-2
<b>LOCK WASHER</b>	12	5/16	12	5/16														
<b>FELT WASHER</b>																		
<b>EXPANSION PLUG</b>									2	50P1-1	2	50P1-1			2	45P1-9		
<b>RELIEF FITTING</b>																2	90P1-1	
<b>COTTER PIN</b>																		
<b>LOCK RING</b>																2	100P1-1	
<b>CASTLE NUT</b>																		

KIT REF.	77.931.18		78.901.12		78.931.06		78.931.12		78.946.18	
PART REF.	QTY	PART NO.								

# ECONOKIT COMPONENTS

KIT REF.	50.053.06		50.055.07		50.056.07		50.070.04		50.070.07		50.070.18		50.071.04		50.071.06		50.072.06	
PART REF.	QTY	PART NO.	QTY	PART NO.	QTY	PART NO.	QTY	PART NO.	QTY	PART NO.	QTY	PART NO.	QTY	PART NO.	QTY	PART NO.	QTY	PART NO.
KING PIN	2	105.50.3	2	105.11.10	2	105.11.10	2	105.2.1	2	105.12.1	2	105.52.3	2	105.2.1	2	105.13.6	2	105.37.4
BUSHING	4	201.2.3	4	201.11.7	4	201.11.10	4	201.2.1	4	201.12.1	4	201.15.7	4	201.2.1	4	201.13.4	4	201.13.7
STEEL LINER																		
TAPER LOCK PINS	2	60M2-3	2	60M1-15	2	60M1-15	4	602.4.1	2	60M3-1	2	60M1-14	4	602.4.1	2	60M2-17	2	60M1-10
											2	60M1-7				2	60M1-11	
END PLATE / PLUG													4	401.143.1	4	45P2-4	4	45P2-4
O-RING GASKET	4	92P1-19	4	41P3-6	4	41P3-6	2	41P3-4	4	41P3-1			4	92P1-16				
BUSHING SEAL			4	91P1-45	4	91P1-42					4	91P1-41	4	91P1-43	4	91P1-35	4	91P1-35
BEARING	2	701.4.4	2	701.4.14	2	701.4.19	2	701.4.4	2	701.4.4			2	701.4.34	2	70P2-15	2	701.4.23
BEARING SEAL													2	91P2-15				
SHIM	5	80P1-4	7	80P1-21	7	80P1-21	5	80P1-4	5	80P1-21	5	80P1-25	5	80P1-4	5	80P1-12	5	80P2-10
	5	80P2-1	5	80P2-17	5	80P2-17	5	80P2-1	5	80P2-17	5	80P2-21	5	80P2-1	5	80P2-10		
CAP SCREW													4	5/16-18X3/4				
NUT	2	50P19-1	2	50P19-2	2	50P19-2			2	50P19-2	4	50P19-1			8	5/16-18X3/4	2	50P19-1
LOCK WASHER							4	5/16					8	5/16				
FELT WASHER																		
EXPANSION PLUG							2	45P1-6										
RELIEF FITTING							2	90P1-3					2	90P1-3				
COTTER PIN																		
LOCK RING							2	100P1-4										
CASTLE NUT																		

KIT REF.	50.102.09		50.103.19		50.108.09		50.109.09		50.120.05		50.120.09		50.120.18		50.121.05		50.121.07	
PART REF.	QTY	PART NO.	QTY	PART NO.	QTY	PART NO.	QTY	PART NO.	QTY	PART NO.	QTY	PART NO.	QTY	PART NO.	QTY	PART NO.	QTY	PART NO.
KING PIN	2	105.37.1	2	105.56.1	2	105.27.1	2	105.14.2	2	105.24.10	2	105.38.2	2	105.33.3	2	105.24.10	2	105.21.8
BUSHING	4	201.13.1	4	201.13.1	4	201.14.4	4	201.14.4	4	201.16.9	4	201.21.11	4	201.20.1	4	201.16.9	4	201.19.8
STEEL LINER																		
TAPER LOCK PINS	2	60M4-10	4	60M2-20	2	60M2-11	4	602.4.1	2	60M2-15	2	60M2-19	2	60M1-1	2	60M2-15	2	60M4-7
	2	60M4-11								2	60M2-20	2	60M1-8				2	60M4-8
	2	60M7-8																
END PLATE / PLUG					4	401.3.1	4	401.3.1	4	401.129.1			4	401.128.1	4	401.129.1	4	401.128.1
O-RING GASKET	4	92P1-16	4	92P1-28	4	92P1-8	4	92P1-8	4	41P5-2	4	92P1-20	4	92P1-4	4	41P5-2	4	92P1-4
BUSHING SEAL	4	91P1-14	4	91P1-14	4	91P1-19			4	91P1-25	4	91P1-32	4	91P1-29	4	91P1-25		
BEARING	2	701.4.35	2	701.4.35	2	701.4.5	2	701.4.5	2	701.4.19	2	701.4.21	2	701.4.27	2	70P2-13	2	701.4.18
BEARING SEAL					2	91P2-6												2
SHIM	5	80P1-22	5	80P1-22	7	80P1-1	7	80P1-1	5	80P1-14	6	80P1-23	5	80P1-19	5	80P1-14	5	80P1-2
	5	80P2-18	5	80P2-18					5	80P2-11	6	80P2-19	3	80P2-15	5	80P2-11	5	80P2-5
											4	80P3-30	4	80P3-33				
CAP SCREW					12	5/16-18X3/4	12	5/16-18X3/4	12	5/16-18X1	12	5/16-18X1	12	5/16-18X1	12	5/16-18X1		
NUT			4	50P19-2	2	50P19-3			2	50P19-3	4	50P19-2	4	50P19-1	2	50P19-3		
LOCK WASHER					12	5/16	12	5/16	12	5/16	12	5/16	12	5/16	12	5/16		
FELT WASHER																		
EXPANSION PLUG																		2
RELIEF FITTING																		45P1-16
COTTER PIN																		
LOCK RING																		2
CASTLE NUT																		100P1-7

KIT REF.	50.073.06		50.075.06		50.076.06		50.080.18		50.095.06		50.095.07		50.096.06		50.098.09		50.101.09	
PART REF.	QTY	PART NO.	QTY	PART NO.	QTY	PART NO.	QTY	PART NO.	QTY	PART NO.	QTY	PART NO.	QTY	PART NO.	QTY	PART NO.	QTY	PART NO.
KING PIN	2	105.50.2	2	105.25.1	2	105.25.1	2	105.52.2	2	105.26.1	2	95.16.7	2	105.26.1	2	105.12.3	2	105.13.1
BUSHING	4	201.2.7	4	201.14.6	4	201.14.6	4	201.15.7	4	201.16.7	2	201.14.1	4	201.16.7	4	201.12.3	4	201.13.1
											2	201.14.2						
STEEL LINER												2	315.16.4					
TAPER LOCK PINS	2	60M2-3	2	60M1-1	2	60M1-1	2	60M1-14	2	60M1-1			2	60M1-1	2	60M7-1	2	60M7-1
			2	60M1-2	2	60M1-2	2	60M1-7	2	60M1-2			2	60M1-2				
END PLATE / PLUG					4	45P2-5							4	45P2-5				
O-RING GASKET	4	92P1-19	2	41P7-1					2	41P7-1	2	41P4-1			4	41P3-3	4	92P1-16
BUSHING SEAL			4	91P1-16	4	91P1-16	4	91P1-41	4	91P3-1			4	91P3-1			4	91P1-14
BEARING	2	701.4.4	2	701.4.5	2	701.4.5	2	701.4.5	2	701.4.1	2	701.4.5	2	701.4.1	2	701.4.4	2	701.4.35
BEARING SEAL											2	91P2-15						
SHIM	5	80P1-4	5	80P1-5	5	80P1-5	5	80P1-25	9	80P1-1	9	80P2-9	9	80P1-1	5	80P1-4	5	80P1-22
	5	80P2-1	5	80P2-2	5	80P2-2	5	80P2-21			2	80P3-7			5	80P2-1	5	80P2-18
											2	80P3-9						
CAP SCREW																		
NUT	2	50P19-1	4	50P19-1	4	50P19-1	4	50P19-1	4	50P19-1			4	50P19-1	2	50P19-2	2	50P19-2
LOCK WASHER																		
FELT WASHER																		
EXPANSION PLUG			2	45P1-11					2	45P1-8	2	45P1-11						
RELIEF FITTING																		
COTTER PIN												2	102P16-1					
LOCK RING			2	100P1-3					2	100P1-2	2	100P1-3						
CASTLE NUT									2	50P14-3								

KIT REF.	50.121.08		50.122.05		50.123.05		50.125.07		50.125.23		50.126.23		50.127.23		50.130.23		50.139.09	
PART REF.	QTY	PART NO.	QTY	PART NO.	QTY	PART NO.	QTY	PART NO.	QTY	PART NO.	QTY	PART NO.	QTY	PART NO.	QTY	PART NO.	QTY	PART NO.
KING PIN			2	105.35.3	2	105.55.2	2	95.16.6	2	105.18.2	2	105.18.2	2	105.18.2	2	105.21.3	2	105.24.1
BUSHING	4	201.18.10	4	201.19.10	2	201.19.10	4	201.16.7	4	201.18.1	4	201.18.1	4	201.18.1	4	201.20.1	4	201.17.1
STEEL LINER							2	315.16.2										
TAPER LOCK PINS			2	60M1-9	2	60M1-16			2	60M2-8	2	60M2-8	2	60M2-8	2	60M1-1	2	60M2-11
					2	60M1-17												
END PLATE / PLUG	4	45P8-1	4	45P6-1	4	45P6-1												

# ECONOKIT COMPONENTS

KIT REF.	50.140.09		50.141.19		50.146.05		50.147.05		50.160.19		50.180.05		50.180.18		50.181.18		50.309.09	
PART REF.	QTY	PART NO.	QTY	PART NO.	QTY	PART NO.	QTY	PART NO.	QTY	PART NO.	QTY	PART NO.	QTY	PART NO.	QTY	PART NO.	QTY	PART NO.
KING PIN	2	105.16.13	2	105.38.6	2	105.35.2	2	105.55.1	2	105.38.4	2	105.35.1	2	105.22.5	2	105.22.2	2	105.24.2
BUSHING	4	201.17.1	4	201.21.10	4	201.18.8	4	201.18.8	4	201.21.10	4	201.18.4	4	201.21.2	4	201.21.2	4	201.17.1
STEEL LINER																		
TAPER LOCK PINS	4	602.4.1	4	60M2-19	2	60M1-9	2	60M1-16	2	60M1-12	2	60M2-18	2	60M1-1	2	60M1-4	2	60M2-11
			2	60M1-17			2	60M1-17	2	60M1-13			2	60M1-8	2	60M1-8		
END PLATE / PLUG							4	45P6-1							4	401.128.2		
O-RING GASKET	4	92P1-15	4	92P1-20	4	93P1-12	4	93P1-12	4	92P1-21	4	41P11-1	4	41P4-2	4	92P1-9	4	92P1-15
			4	92P1-21														
BUSHING SEAL	4	91P3-1	4	91P1-34	4	91P1-36	4	91P1-36	4	91P1-34	4	91P1-36	4	91P1-15	4	91P1-15	4	91P3-1
BEARING	2	701.4.1	2	701.4.37	2	701.4.24	2	701.4.25	2	701.4.37	2	701.4.24	2	701.4.37	2	701.4.37	2	701.4.1
BEARING SEAL	2	91P2-2															2	91P2-2
SHIM	7	80P1-1	3	80P1-23	3	80P1-24	3	80P1-24	3	80P1-23	3	80P1-9	3	80P1-9	3	80P1-9	7	80P1-1
	2	80P3-13	3	80P2-19	5	80P2-20	5	80P2-20	3	80P2-19	3	80P2-7	3	80P2-7	3	80P2-7		
			4	80P3-30	2	80P3-31	2	80P3-31	2	80P3-30	2	80P3-29	2	80P3-29	2	80P3-29		
												2	80P3-34	2	80P3-34			
CAP SCREW											16	5/16-18X1	12	5/16-18 X 1	12	5/16-18 X 1		
NUT			4	50P19-2	2	50P19-3	4	50P19-2	4	50P19-2	2	50P19-3	4	50P19-1	4	50P19-1	2	50P19-3
LOCK WASHER											16	5/16	12	5/16	12	5/16		
FELT WASHER																		
EXPANSION PLUG																		
RELIEF FITTING																		
COTTER PIN																		
LOCK RING																		
CASTLE NUT																		

KIT REF.	50.961.12		50.970.18		50.981.18		54.901.18		55.350.06		57.931.18		58.901.12		58.931.06		58.931.12	
PART REF.	QTY	PART NO.	QTY	PART NO.	QTY	PART NO.	QTY	PART NO.	QTY	PART NO.	QTY	PART NO.	QTY	PART NO.	QTY	PART NO.	QTY	PART NO.
KING PIN	2	105.21.3	2	105.16.5	2	105.21.12	2	105.14.1	2	105.10.3	2	105.21.3	2	105.22.1	2	105.22.2	2	105.22.2
BUSHING	4	201.20.1	4	201.16.7	4	201.19.10	4	201.14.6	4	201.5.1	4	201.20.1	4	201.21.1	4	201.21.2	4	201.21.2
STEEL LINER																		
TAPER LOCK PINS	2	60M1-7	4	602.4.1	2	60M1-7	4	602.4.1	2	60M2-3	2	60M1-1	4	60M4-4	2	60M1-3	2	60M1-3
	2	60M1-8			2	60M1-8					2	60M1-2			2	60M1-4	2	60M1-4
END PLATE / PLUG									4	45P2-2								
O-RING GASKET	4	41P7-1	2	41P3-4			2	41P7-1			4	41P7-1	2	41P4-2	4	41P4-2	4	41P4-2
BUSHING SEAL	4	91P1-29			4	91P1-29			4	91P1-23	4	91P1-29			4	91P1-15	4	91P1-15
BEARING	2	701.4.27	2	701.4.1	2	701.4.27	2	701.4.5	2	70P2-3	2	701.4.30	2	701.4.11	2	701.4.11	2	701.4.37
BEARING SEAL																		
SHIM	5	80P1-2	13	80P1-1	3	80P1-19	5	80P1-5	5	80P1-10	5	80P1-2	5	80P1-9	5	80P1-9	5	80P1-9
	8	80P2-5			3	80P2-15	5	80P2-2	5	80P2-8	8	80P2-5	9	80P2-7	9	80P2-7	9	80P2-7
															2	80P3-29	2	80P3-29
															2	80P3-34	2	80P3-34
CAP SCREW																		
NUT	4	50P19-1			4	50P19-1			2	50P19-1	4	50P19-1			4	50P19-1	4	50P19-1
LOCK WASHER																		
FELT WASHER																		
EXPANSION PLUG											2	45P1-8			2	45P1-10		
RELIEF FITTING																		
COTTER PIN																		
LOCK RING																		
CASTLE NUT																		

KIT REF.	50.310.09		50.533.13		50.616.13		50.901.12		50.921.12		50.931.12		50.941.06		50.941.18		50.942.06	
PART REF.	QTY	PART NO.	QTY	PART NO.	QTY	PART NO.	QTY	PART NO.	QTY	PART NO.	QTY	PART NO.	QTY	PART NO.	QTY	PART NO.	QTY	PART NO.
KING PIN	2	105.16.12	2	95.15.3	2	95.18.2	2	105.21.1	2	105.21.2	2	105.21.3	2	105.33.2	2	105.52.1	2	105.33.2
BUSHING	4	201.17.1	2	201.16.3	2	201.23.1	4	201.19.5	4	201.20.1	4	201.20.1	4	201.19.5	4	201.15.7	4	201.19.5
STEEL LINER																		
TAPER LOCK PINS	4	602.4.1					2	60M7-3	2	60M7-3	2	60M1-1	2	60M1-1	2	60M1-7	2	60M1-1
							2	60M7-4	2	60M7-4	2	60M1-2	2	60M1-2	2	60M1-14	2	60M1-2
END PLATE / PLUG			2	45P10-2	2	45P10-1									4	401.139.1	4	45P2-3
O-RING GASKET	4	92P1-15	2	92P1-30	2	92P1-30	2	41P7-1	4	41P7-1	2	41P7-1	4	41P7-1	4	92P1-26		
BUSHING SEAL	4	91P3-1	2	91P1-11	2	91P1-21	4	91P1-29	4	91P1-6	4	91P1-29	4	91P1-29	4	91P1-41	4	91P1-29
			2	91P1-12	2	91P1-22												
BEARING	2	701.4.1	2	70P2-1	2	70P2-8	2	701.4.2	2	701.4.27	2	701.4.27	2	701.4.2	2	701.4.5	2	701.4.2
			2	70P3-2	2	70P3-3												
BEARING SEAL	2	91P2-2													2	91P2-15		
SHIM	11	80P1-1					5	80P1-2	5	80P1-2	5	80P1-2	5	80P1-2	5	80P2-21	9	80P1-2
	12	80P3-13					8	80P2-5	8	80P2-5	8	80P2-5	8	80P2-5			7	80P2-5
CAP SCREW															12	5/16-18X1		
NUT							4	50P19-2	4	50P19-2	4	50P19-1	4	50P19-1	4	50P19-1	4	50P19-1
LOCK WASHER															12	5/16		
FELT WASHER																		
EXPANSION PLUG			2	50P4-1	2	50P4-1	2	45P1-9										
RELIEF FITTING							2	90P1-1										
COTTER PIN																		
LOCK RING							2	100P1-1										
CASTLE NUT																		

KIT REF.	58.946.18	
PART REF.	QTY	PART NO.
KING PIN	2	105.21.14
BUSHING	2	201.19.10
	2	201.19.11
STEEL LINER		
TAPER LOCK PINS	2	60M1-3
	2	60M1-4
	2	60M1-8
END PLATE / PLUG	4	45P7-1
O-RING GASKET		
BUSHING SEAL	4	91P1-29
BEARING	2	701.4.27
BEARING SEAL		
SHIM	5	80P1-2
	5	80P2-5
CAP SCREW		
NUT	4	50P19-1
LOCK WASHER		
FELT WASHER		
EXPANSION PLUG		
RELIEF FITTING		
COTTER PIN		
LOCK RING		
CASTLE NUT		

### QWIKTIE® Tie Rod Assembly



**HIGHLY ADAPTABLE FOR  
MAXIMUM EFFICIENCY**

Designed to increase simplicity and safety. STEMCO® QWIKTIE® tie rod assembly offers a highly adaptable solution that can accommodate a wide range of straight tie rod lengths.

#### Advanced Technology

QWIKTIE's versatile range of adjustment makes it a flexible stock addition. QWIKTIE tie rod assemblies are highly adjustable to fit over 80% of the straight tie rod lengths and styles in the market. QWIKTIE features easy color attributes for identification and accurate installation. Patent Pending.

#### Increased Versatility

With a versatile tie rod solution, QWIKTIE tie rod assemblies reduce overhead for maximum efficiency. QWIKTIE fits from 57 3/8" to 73 7/8" total length from grease zerk to zerk.

#### Increased Strength

Increased strength and a more even clamping force holds the alignment longer, reducing stress on other suspension components providing increased fuel and tire mileage.

#### Greater Accuracy

Finer threads provide a more precise adjustment, reducing stress on other steering components. Threads are pre-lubricated for ease of installation and easy adjustment over time.

#### Safe and Secure

Alignment settings are easily adjusted in a timely manner to achieve a safe, secure connection between the tie rod and threaded tie rod end.



Making the Roadways Safer®

## TIE ROD END INTERCHANGE TO QWIKTIE ASSEMBLY

COMPETITOR #	ASSEMBLY	LEFT*	RIGHT*
<b>AUTOCAR</b>			
872469	QT967SS		QTE967R
872470	QT967SS	QTE967L	
85108888	QT108SB	QTE108L	
85108889	QT108SB		QTE108R
85112008	QT108SB		QTE108R
85112009	QT108SB	QTE108L	
370240004	QT967SS	QTE967L	
370240005	QT967SS		QTE967R
370245001	QT108SB	QTE108L	
370245002	QT108SB		QTE108R
887783A	QT108SB	QTE108L	
887784A	QT108SB		QTE108R
A8010185	QT108SB		QTE108R
A8010186	QT108SB	QTE108L	
A8015593	QT108SB	QTE108L	
A8015594	QT108SB		QTE108R
L24SV5042A12	QT967SS		QTE967R
L24SV5043A12	QT967SS	QTE967L	

COMPETITOR #	ASSEMBLY	LEFT*	RIGHT*
<b>AUTOMANN</b>			
462.ES187L	QT967SS	QTE967L	
462.ES187R	QT967SS		QTE967R
462.ES2090L	QT108SB	QTE108L	
462.ES2090LS	QT108SB	QTE108L	
462.ES2091R	QT108SB		QTE108R
462.ES2091RS	QT108SB		QTE108R
462.ES2118L	QT967SS	QTE967R	
462.ES2203R	QT967SS		QTE967R
462.ES2614L	QT967SS	QTE967L	
462.ES2614R	QT967SS		QTE967R
462.ES3030R	QT108SB		QTE108R
462.ES3031L	QT108SB	QTE108L	
462.ES3033L	QT108SB	QTE108L	
462.ES3034R	QT108SB		QTE108R
462.ES3176R	QT967SS		QTE967R
462.ES3177L	QT967SS	QTE967L	
462.ES3219L	QT967SS	QTE967L	
462.ES3220R	QT967SS		QTE967R
462.ES3297R	QT967SS		QTE967R
462.ES3298L	QT967SS	QTE967L	
462.ES3312R	QT967SS		QTE967R
462.ES3442R	QT967SS		QTE967R
462.ES3443L	QT967SS	QTE967L	
462.ES346L	QT108SB		QTE108R
462.ES346R	QT108SB	QTE108L	
462.ES411L	QT967SS	QTE967L	
462.ES411R	QT967SS		QTE967R
462.ES423L	QT967SS	QTE967L	
462.ES423R	QT967SS		QTE967R
462.ES431L	QT108SB	QTE108L	
462.ES431LS	QT108SB	QTE108L	
462.ES431R	QT108SB	QTE108L	
462.ES431RS	QT108SB	QTE108L	
462.ES4601L	QT108SB	QTE108L	
462.ES4601R	QT108SB		QTE108R

COMPETITOR #	ASSEMBLY	LEFT*	RIGHT*
<b>AUTOMANN CONT.</b>			
462.ES9001L	QT967SS	QTE967L	
462.ES9001R	QT967SS		QTE967R
462.ES9328L	QT108SB	QTE108L	
462.ES9329R	QT108SB		QTE108R
462.ES9678L	QT967SS	QTE967L	
462.ES9679R	QT967SS		QTE967R
463.DS1261	QT967SS	QTE967L	QTE967R
463.DS1367A	QT967SS	QTE967L	QTE967R
463.DS1368A	QT967SS	QTE967L	QTE967R
463.DS1379A	QT967SS	QTE967L	QTE967R
463.DS1380A	QT967SS	QTE967L	QTE967R
463.DS3138	QT108SB	QTE108L	QTE108R
463.DS3156	QT967SS	QTE967L	QTE967R
463.DS3158	QT967SS	QTE967L	QTE967R
463.DS4301	QT967SS	QTE967L	QTE967R
463.DS4602	QT967SS	QTE967L	QTE967R
463.DS5003	QT967SS	QTE967L	QTE967R
463.DS5090	QT967SS	QTE967L	QTE967R
463.DS55710	QT967SS	QTE967L	QTE967R
463.DS7526	QT967SS	QTE967L	QTE967R
463.DS9800	QT967SS	QTE967L	QTE967R
463.DS9801	QT108SB	QTE108L	QTE108R
463.DS9802	QT108SB	QTE108L	QTE108R
463.DS9803	QT967SS	QTE967L	QTE967R
463.DS9804	QT967SS	QTE967L	QTE967R
463.DS9807	QT108SB	QTE108L	QTE108R
463.DS9808	QT967SS	QTE967L	QTE967R
463.DS9811	QT108SB	QTE108L	QTE108R
463.DS9812	QT108SB	QTE108L	QTE108R
463.DS9813	QT967SS	QTE967L	QTE967R
463.DS9816	QT108SB	QTE108L	QTE108R
463.DS9817	QT108SB	QTE108L	QTE108R
463.DS9818	QT108SB	QTE108L	QTE108R
463.DS9819	QT108SB	QTE108L	QTE108R
463.DS9820	QT967SS	QTE967L	QTE967R
463.DS9822	QT967SS	QTE967L	QTE967R
463.DS9823	QT967SS	QTE967L	QTE967R
463.DS9824	QT108SB	QTE108L	QTE108R
463.DS9826	QT108SB	QTE108L	QTE108R
463.DS9827	QT108SB	QTE108L	QTE108R
463.DS9828	QT108SB	QTE108L	QTE108R
463.DS9829	QT108SB	QTE108L	QTE108R
463.DS9830	QT967SS	QTE967L	QTE967R
463.DS9831	QT108SB	QTE108L	QTE108R
463.DS9832	QT108SB	QTE108L	QTE108R
463.DS9833	QT967SS	QTE967L	QTE967R
463.DS9834	QT108SB	QTE108L	QTE108R
463.DS9835	QT967SS	QTE967L	QTE967R
463.DS9836	QT108SB	QTE108L	QTE108R
463.DS9837	QT108SB	QTE108L	QTE108R
463.DS9838	QT108SB	QTE108L	QTE108R
463.DS9839	QT967SS	QTE967L	QTE967R
463.DS9840	QT967SS	QTE967L	QTE967R
463.DS9841	QT967SS	QTE967L	QTE967R

COMPETITOR #	ASSEMBLY	LEFT*	RIGHT*
<b>AUTOMANN CONT.</b>			
463.DS9842	QT108SB	QTE108L	QTE108R
463.DS9843	QT108SB	QTE108L	QTE108R
463.DS9845	QT967SS	QTE967L	QTE967R
463.DS9846	QT967SS	QTE967L	QTE967R
463.DS9847	QT967SS	QTE967L	QTE967R
463.DS9848	QT967SS	QTE967L	QTE967R
463.DS9850	QT108SB	QTE108L	QTE108R
463.DS9853	QT967SS	QTE967L	QTE967R
463.DS9856	QT967SS	QTE967L	QTE967R
463.DS9857	QT108SB	QTE108L	QTE108R
463.DS9858	QT967SS	QTE967L	QTE967R
463.DS9859	QT108SB	QTE108L	QTE108R
463.DS9861	QT108SB	QTE108L	QTE108R
463.DS9862	QT967SS	QTE967L	QTE967R
463.DS9864	QT967SS	QTE967L	QTE967R
463.DS9865	QT108SB	QTE108L	QTE108R
463.DS9868	QT108SB	QTE108L	QTE108R
463.DS9869	QT108SB	QTE108L	QTE108R
463.DS9870	QT967SS	QTE967L	QTE967R
463.DS9871	QT108SB	QTE108L	QTE108R
463.DS9872	QT108SB	QTE108L	QTE108R
463.DS9873	QT108SB	QTE108L	QTE108R
463.DS9877	QT967SS	QTE967L	QTE967R
463.DS9878	QT967SS	QTE967L	QTE967R
463.DS9879	QT967SS	QTE967L	QTE967R
463.DS9880	QT967SS	QTE967L	QTE967R
463.DS9881	QT967SS	QTE967L	QTE967R
463.DS9882	QT108SB	QTE108L	QTE108R
463.DS9883	QT108SB	QTE108L	QTE108R
463.DS9884	QT108SB	QTE108L	QTE108R
463.DS9885	QT108SB	QTE108L	QTE108R
463.DS9886	QT967SS	QTE967L	QTE967R
463.DS9887	QT967SS	QTE967L	QTE967R
463.DS9889	QT108SB	QTE108L	QTE108R
463.DS9890	QT108SB	QTE108L	QTE108R
463.DS9891	QT108SB	QTE108L	QTE108R
463.DS9893	QT967SS	QTE967L	QTE967R
463.DS9896	QT108SB	QTE108L	QTE108R
463.DS9897	QT108SB	QTE108L	QTE108R
463.DS9898	QT967SS	QTE967L	QTE967R
463.DS9899	QT967SS	QTE967L	QTE967R
463.DS9901	QT967SS	QTE967L	QTE967R
463.DS9902	QT108SB	QTE108L	QTE108R
463.DS9903	QT967SS	QTE967L	QTE967R

COMPETITOR #	ASSEMBLY	LEFT*	RIGHT*
<b>BATCO</b>			
21187L	QT967SS	QTE967L	
21187R	QT967SS		QTE967R
212041L	QT108SB	QTE108L	
212091R	QT108SB		QTE108R
212115R	QT108SB		QTE108R
212116L	QT108SB	QTE108L	
212118L	QT967SS		QTE967R
212202R	QT108SB		QTE108R
212204R	QT108SB		QTE108R

\*Only compatible with STEMCO Cross Tube QTT5773

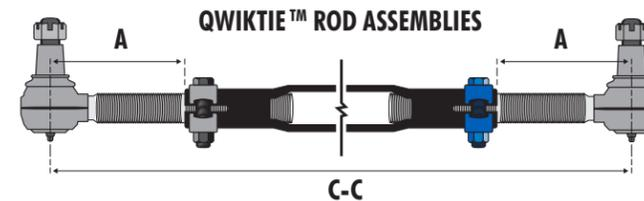

Fit a wide range of configurations, QT967SS typical for 12,000 # axles (Green cap) QT108SB typical for 16 & 20,000 # axles (Red cap) Qwik Tie Assemblies adjust C-C 57 3/8" to 73 7/8"

When extending Rod Ends to the proper C-C Maintain equal distance on both Left and Right A=A Do not overextend beyond the groove on the thread

# TIE ROD END INTERCHANGE TO QWIKTIE ASSEMBLY

**COMPETITOR # ASSEMBLY LEFT\* RIGHT\***

**BATCO CONT.**

212207R	QT108SB		QTE108R
212208R	QT108SB		QTE108R
212209R	QT108SB		QTE108R
21220R	QT108SB		QTE108R
212614R	QT967SS		QTE967R
213030R	QT108SB		QTE108R
213034R	QT108SB		QTE108R
21346L	QT108SB		QTE108R
21346R	QT108SB	QTE108L	
21376L	QT108SB	QTE108L	
21411L	QT967SS	QTE967L	
21411R	QT967SS		QTE967R
21423L	QT967SS	QTE967L	
21423R	QT967SS		QTE967R
21431L	QT108SB		QTE108R
21431R	QT108SB	QTE108L	

**BLUE BIRD**

63810	QT967SS	QTE967L	
663811	QT108SB		QTE967R
2597151	QT967SS	QTE967L	
2597250	QT108SB		QTE967R
4278487	QT967SS	QTE967L	
4278503	QT108SB		QTE967R

**CHEVROLET / GMC**

685504	QT108SB		QTE108R
685505	QT108SB	QTE108L	
798203	QT108SB		QTE108R
798204	QT108SB	QTE108L	
2452860	QT108SB		QTE108R
2452861	QT108SB	QTE108L	
12541319	QT108SB	QTE108L	
12541320	QT108SB		QTE108R
15579760	QT108SB		QTE108R
15617769	QT967SS	QTE967L	QTE967R
88936085	QT108SB	QTE108L	
88936086	QT108SB		QTE108R

**CHRYSLER**

1643277	QT967SS		QTE967R
1643278	QT967SS	QTE967L	
2585607	QT108SB	QTE108L	
2585608	QT108SB		QTE108R
3634206	QT108SB		QTE108R
3634207	QT108SB	QTE108L	
3744496	QT967SS		QTE967R
3744497	QT967SS	QTE967L	
L24SV5042A12	QT967SS		QTE967R
L24SV5043A12	QT967SS	QTE967L	

**DANA**

2692705	QT967SS		QTE967R
120TR109	QT967SS	QTE967L	
120TR110	QT967SS		QTE967R
120TR111	QT967SS	QTE967L	
120TR112	QT967SS		QTE967R
140TR111	QT967SS	QTE967L	

**COMPETITOR # ASSEMBLY LEFT\* RIGHT\***

**DANA CONT.**

140TR112	QT967SS		QTE967R
220TR115	QT108SB	QTE108L	
220TR116	QT108SB		QTE108R
220TR118	QT108SB	QTE108L	
220TR119	QT108SB		QTE108R

**DAYTON**

310-121	QT967SS	QTE967L	
310-122	QT967SS		QTE967R
310-169	QT108SB	QTE108L	
310-170	QT108SB		QTE108R
310-215	QT967SS	QTE967L	
310-216	QT967SS		QTE967R
310-222	QT967SS	QTE967L	
310-223	QT967SS		QTE967R
310-228	QT108SB		QTE108R
310-228SF	QT108SB		QTE108R
310-229	QT108SB	QTE108L	
310-229SF	QT108SB	QTE108L	
310-285	QT967SS	QTE967L	
310-286	QT967SS		QTE967R
310-296	QT967SS		QTE967R
310-316	QT108SB		QTE108R
310-317	QT967SS		QTE967R
310-322	QT108SB		QTE108R
310-381	QT967SS		QTE967R
310-395	QT108SB		QTE108R
310-396	QT108SB	QTE108L	
310-397	QT108SB	QTE108L	
310-397SF	QT108SB	QTE108L	
310-398	QT108SB		QTE108R
310-398SF	QT108SB		QTE108R
310-424	QT108SB	QTE108L	
310-425	QT108SB		QTE108R
310-433	QT108SB	QTE108L	
310-434	QT108SB		QTE108R
310-436	QT967SS		QTE967R
310-455	QT967SS		QTE967R
310-456	QT967SS	QTE967L	
310-463	QT108SB	QTE108L	
310-464	QT108SB		QTE108R
310-471	QT967SS	QTE967L	
310-472	QT967SS		QTE967R
310-483	QT967SS		QTE967R
310-484	QT967SS	QTE967L	
347-400A	QT967SS	QTE967L	QTE967R

**DODGE**

1643277	QT967SS	QTE967L	
1643278	QT967SS		QTE967R
3744496	QT967SS		QTE967R
3744497	QT967SS	QTE967L	

**EATON**

310216	QT967SS		QTE967R
817018	QT967SS	QTE967L	
817019	QT967SS		QTE967R

**COMPETITOR # ASSEMBLY LEFT\* RIGHT\***

**EATON CONT.**

818471	QT108SB		QTE108R
818472	QT108SB	QTE108L	
820626	QT108SB	QTE108L	
820627	QT108SB		QTE108R
820694	QT108SB	QTE108L	
820695	QT108SB		QTE108R
970701	QT967SS	QTE967L	
970702	QT967SS		QTE967R
971128	QT108SB	QTE108L	
971129	QT108SB		QTE108R
1006146	QT967SS	QTE967L	
1006146	QT967SS	QTE967L	
1006147	QT967SS		QTE967R
1006148	QT967SS	QTE967L	
1006149	QT967SS		QTE967R
1009009	QT967SS	QTE967L	
1009010	QT967SS		QTE967R
L24SV5042A12	QT967SS		QTE967R
L24SV5043A12	QT967SS	QTE967L	
TE2007	QT967SS	QTE967L	
TE2008	QT967SS		QTE967R
TE2017	QT108SB	QTE108L	
TE2018	QT108SB		QTE108R
TE2021	QT108SB	QTE108L	
TE2022	QT108SB		QTE108R
TE2026	QT967SS		QTE967R
TE2027	QT967SS	QTE967L	
TE2029	QT967SS	QTE967L	
TE2030	QT967SS		QTE967R
TE2041	QT108SB	QTE108L	
TE2042	QT108SB		QTE108R
TE2044	QT108SB		QTE108R
TE2045	QT108SB	QTE108L	
TE2046	QT967SS		QTE967R
TE2048	QT967SS		QTE967R
TE2349	QT108SB		QTE108R
TE2350	QT108SB	QTE108L	
TE2453	QT108SB		QTE108R

**ELGIN**

ES187L	QT967SS	QTE967L	
ES187R	QT967SS		QTE967R
ES2091R	QT108SB		QTE108R
ES2113R	QT108SB	QTE108L	
ES2118L	QT967SS		QTE967R
ES2203R	QT967SS		QTE967R
ES2208R	QT108SB		QTE108R
ES2614R	QT967SS		QTE967R
ES3030R	QT108SB		QTE108R
ES3176R	QT967SS		QTE967R
ES3177L	QT967SS	QTE967L	
ES3178R	QT967SS		QTE967R
ES3216R	QT967SS		QTE967R
ES3217L	QT967SS	QTE967L	

\*Only compatible with STEMCO Cross Tube QTT5773

**COMPETITOR # ASSEMBLY LEFT\* RIGHT\***

**ELGIN CONT.**

ES3218R	QT967SS		QTE967R
ES3219L	QT967SS	QTE967L	
ES3220R	QT967SS		QTE967R
ES3297R	QT967SS		QTE967R
ES3298L	QT967SS	QTE967L	
ES3312R	QT967SS		QTE967R
ES3442R	QT967SS		QTE967R
ES3443L	QT967SS	QTE967L	
ES346L	QT108SB		QTE108R
ES346R	QT108SB	QTE108L	
ES3476	QT967SS		QTE967R
ES3477	QT967SS	QTE967L	
ES411L	QT967SS	QTE967L	
ES411R	QT967SS		QTE967R
ES423L	QT967SS	QTE967L	
ES423R	QT967SS		QTE967R
ES431L	QT108SB		QTE108R
ES431LA	QT108SB		QTE108R
ES431R	QT108SB	QTE108L	
ES431RA	QT108SB	QTE108L	

**EUCLID**

E-10137	QT967SS		QTE967R
E-10138	QT967SS	QTE967L	
E-11023	QT967SS		QTE967R
E-11788	QT967SS		QTE967R
E-11789	QT967SS	QTE967L	
E-11981	QT967SS		QTE967R
E-14326	QT967SS	QTE967L	
E-4610	QT967SS	QTE967L	
E-4611	QT967SS		QTE967R
E-4614	QT967SS	QTE967L	
E-4615	QT967SS		QTE967R
E-4616	QT108SB	QTE108L	
E-4617	QT108SB		QTE108R
E-4617TU	QT108SB		QTE108R
E-4618	QT108SB		QTE108R
E-4619	QT108SB	QTE108L	
E-4628	QT108SB	QTE108L	
E-4629	QT108SB		QTE108R
E-4630	QT967SS	QTE967L	
E-4631	QT967SS		QTE967R
E-4640	QT967SS		QTE967R
E-4642	QT108SB		QTE108R
E-5393	QT108SB		QTE108R
E-5396	QT108SB	QTE108L	
E-5397	QT108SB		QTE108R
E-5470	QT967SS		QTE967R
E-6849	QT967SS		QTE967R
E-6856	QT108SB		QTE108R
E-6857	QT108SB	QTE108L	
E-8757	QT967SS	QTE967L	
E-8758	QT967SS		QTE967R
E-9661	QT967SS	QTE967L	QTE967R
E-9877	QT108SB	QTE108L	

**COMPETITOR # ASSEMBLY LEFT\* RIGHT\***

**EUCLID CONT.**

E-9878	QT108SB	QTE108L	
E-9879	QT108SB		QTE108R
E-9880	QT108SB	QTE108L	
E-9949	QT967SS	QTE967L	
E-9950	QT967SS		QTE967R
E-9951	QT967SS	QTE967L	
E-9952	QT967SS		QTE967R
E-9956	QT967SS		QTE967R
E-9962	QT967SS	QTE967L	
E-9963	QT967SS		QTE967R
E-9964	QT967SS	QTE967L	QTE967R

**FLAGG**

ES187L	QT967SS	QTE967L	
ES187R	QT967SS		QTE967R
ES2090L	QT108SB	QTE108L	
ES2091R	QT108SB		QTE108R
ES2114R	QT108SB		QTE108R
ES2116L	QT108SB	QTE108L	
ES2118L	QT967SS		QTE967R
ES2202R	QT108SB		QTE108R
ES2203R	QT967SS		QTE967R
ES2208R	QT108SB		QTE108R
ES2614R	QT967SS		QTE967R
ES3030R	QT108SB		QTE108R
ES3031L	QT108SB	QTE108L	
ES3176R	QT967SS		QTE967R
ES3177L	QT967SS	QTE967L	
ES3178R	QT967SS		QTE967R
ES3216R	QT967SS		QTE967R
ES3217L	QT967SS	QTE967L	
ES3218R	QT967SS		QTE967R
ES3219L	QT967SS	QTE967L	
ES3297R	QT967SS		QTE967R
ES3298L	QT967SS	QTE967L	
ES3312R	QT967SS		QTE967R
ES3442R	QT967SS		QTE967R
ES3443L	QT967SS	QTE967L	
ES3477	QT967SS	QTE967L	
ES376L	QT108SB	QTE108L	
ES376R	QT108SB		QTE108R
ES411L	QT967SS	QTE967L	
ES411R	QT967SS		QTE967R
ES423L	QT967SS	QTE967L	
ES423R	QT967SS		QTE967R
ES431LA	QT108SB		QTE108R
ES431L	QT108SB		QTE108R
ES431R	QT108SB	QTE108L	
ES431RA	QT108SB	QTE108L	
ES431RS	QT108SB	QTE108L	
ES9001L	QT967SS	QTE967L	
ES9001R	QT967SS		QTE967R
ES9009	QT967SS	QTE967L	
ES9010	QT967SS		QTE967R

**COMPETITOR # ASSEMBLY LEFT\* RIGHT\***

# TIE ROD END INTERCHANGE TO QWIKTIE ASSEMBLY

**COMPETITOR # ASSEMBLY LEFT\* RIGHT\***

**FORD CONT.**

F1HZ3280C	QT967SS	QTE967L	QTE967R
F1HZ3A130A	QT967SS		QTE967R
F1HZ3A130B	QT967SS		QTE967R
F1HZ3A131A	QT967SS	QTE967L	
F3HZ3280E	QT967SS	QTE967L	QTE967R
F3HZ3A130B	QT967SS		QTE967R
F3HZ3A131A	QT967SS	QTE967L	
F4HZ3280A	QT967SS	QTE967L	QTE967R
F4HZ3280B	QT967SS	QTE967L	QTE967R
F4HZ3280C	QT967SS	QTE967L	QTE967R
F5HT3280DA	QT967SS	QTE967L	QTE967R
F5HZ3280A	QT967SS	QTE967L	QTE967R
F5HZ3A130AA	QT967SS		QTE967R
F5HZ3A131AA	QT967SS	QTE967L	
F6HZ3A130AA	QT967SS		QTE967R
F6HZ3A131AA	QT967SS	QTE967L	

**FREIGHTLINER**

817018	QT967SS	QTE967L	
817019	QT967SS		QTE967R
1009009	QT967SS	QTE967L	
1009010	QT967SS		QTE967R
6070910	QT108SB	QTE108L	
6073380010	QT108SB	QTE108L	
6073381010	QT967SS	QTE967L	
6073381310	QT108SB		QTE108R
6073381410	QT108SB		QTE108R
6073382410	QT967SS		QTE967R
6803302703	QT967SS	QTE967L	QTE967R
6803302903	QT967SS	QTE967L	QTE967R
6803303603	QT108SB	QTE108L	QTE108R
6803303803	QT967SS	QTE967L	QTE967R
6803303903	QT108SB	QTE108L	QTE108R
6803304403	QT967SS	QTE967L	QTE967R
6803307303	QT108SB	QTE108L	QTE108R
6803308003	QT967SS	QTE967L	QTE967R
6803308303	QT967SS	QTE967L	QTE967R
681-460-15-05	QT108SB		QTE108R
A3144C237	QT108SB	QTE108L	
A3144C549	QT108SB	QTE108L	
A3144D238	QT108SB		QTE108R
A3144D524	QT967SS		QTE967R
A3144D550	QT108SB		QTE108R
A3144E525	QT967SS	QTE967L	
A3144F448	QT108SB		QTE108R
A3144G449	QT108SB	QTE108L	
A3144J296	QT108SB	QTE108L	
A3144K297	QT108SB	QTE108L	
A3144Q225	QT967SS	QTE967L	
A3144R226	QT967SS		QTE967R
A6073381010	QT967SS	QTE967L	
A6073382410	QT967SS		QTE967R
L24SV5001A13	QT967SS		QTE967R
L24SV5001A14	QT967SS		QTE967R

**COMPETITOR # ASSEMBLY LEFT\* RIGHT\***

**FREIGHTLINER CONT.**

L24SV5042A12	QT967SS		QTE967R
L24SV5042B12	QT967SS		QTE967R
L24SV5043A12	QT967SS	QTE967L	
L24SV5043A14	QT967SS	QTE967L	
L24SV5700A12	QT967SS		QTE967R
L28SV5000A14	QT108SB	QTE108L	
L28SV5000A18	QT108SB	QTE108L	
L28SV5000A18	QT108SB	QTE108L	
L28SV5000A30	QT108SB		QTE108R
L28SV5000H29	QT108SB	QTE108L	
L28SV5000H35	QT108SB	QTE108L	
L28SV5001A18	QT108SB		QTE108R
L28SV5003A14	QT108SB	QTE108L	
L28SV5003B18	QT108SB		QTE108R
L28SV5004D1	QT108SB		QTE108R
L28SV5200A12	QT108SB		QTE108R
L28SV5200D12	QT108SB		QTE108R
L28SV5201A12	QT108SB	QTE108L	
L28SV5201D12	QT108SB	QTE108L	
L28SV5207B16	QT108SB		QTE108R
MBA6073381010	QT967SS	QTE967L	
MBA6073382410	QT967SS		QTE967R

**HENDRICKSON**

2890	QT967SS	QTE967L	QTE967R
29141	QT967SS	QTE967L	
29142	QT108SB		QTE967R
60239003	QT967SS	QTE967L	QTE967R
60961025	QT967SS	QTE967L	
60961026	QT967SS		QTE967R
60961027	QT967SS	QTE967L	
60961028	QT967SS		QTE967R
60961029	QT967SS	QTE967L	
60961030	QT967SS		QTE967R
60961083	QT967SS	QTE967L	
60961084	QT967SS		QTE967R
60961085	QT967SS	QTE967L	
60961086	QT967SS		QTE967R
64000001	QT967SS	QTE967L	
64000002	QT967SS		QTE967R
64002001	QT967SS	QTE967L	
64002002	QT967SS		QTE967R
64801003	QT967SS	QTE967L	QTE967R
65033001	QT967SS	QTE967L	
65033002	QT967SS		QTE967R
65034001	QT967SS	QTE967L	
65034002	QT967SS		QTE967R
66645001	QT967SS	QTE967L	
66645002	QT967SS		QTE967R
64004-001	QT967SS	QTE967L	
64004-002	QT967SS		QTE967R
R002890	QT967SS	QTE967L	QTE967R

**INDUSTRY STANDARD**

ES-187L	QT967SS	QTE967L	
ES-187R	QT967SS		QTE967R

**COMPETITOR # ASSEMBLY LEFT\* RIGHT\***

**INDUSTRY STANDARD CONT.**

ES-2090L	QT108SB	QTE108L	
ES-2090LS	QT108SB	QTE108L	
ES-2091R	QT108SB		QTE108R
ES-2091RS	QT108SB		QTE108R
ES-2118	QT967SS		QTE967R
ES-2202R	QT108SB		QTE108R
ES-2203R	QT967SS		QTE967R
ES-2207R	QT108SB		QTE108R
ES-2208R	QT108SB		QTE108R
ES-2614L	QT967SS	QTE967L	
ES-2614R	QT967SS		QTE967R
ES-3030R	QT108SB		QTE108R
ES-3031L	QT108SB	QTE108L	
ES-3033L	QT108SB	QTE108L	
ES-3034R	QT108SB		QTE108R
ES-3056	QT108SB		QTE108R
ES-3057	QT108SB	QTE108L	
ES-3058	QT108SB		QTE108R
ES-3176L	QT967SS	QTE967L	
ES-3176R	QT967SS		QTE967R
ES-3177L	QT967SS	QTE967L	
ES-3178R	QT967SS		QTE967R
ES-3216	QT967SS		QTE967R
ES-3219L	QT967SS	QTE967L	
ES-3220R	QT967SS		QTE967R
ES-3297R	QT967SS		QTE967R
ES-3298L	QT967SS	QTE967L	
ES-3312R	QT967SS		QTE967R
ES-3442R	QT967SS		QTE967R
ES-3443L	QT967SS	QTE967L	
ES-346L	QT108SB		QTE108R
ES-346R	QT108SB	QTE108L	
ES-3476	QT967SS		QTE967R
ES-3477	QT967SS	QTE967L	
ES-411L	QT967SS	QTE967L	
ES-411R	QT967SS		QTE967R
ES-423L	QT967SS	QTE967L	
ES-423R	QT967SS		QTE967R
ES-431L	QT108SB		QTE108R
ES-431LS	QT108SB		QTE108R
ES-431R	QT108SB	QTE108L	
ES-431RS	QT108SB	QTE108L	
ES-4601L	QT108SB	QTE108L	
ES-4601R	QT108SB		QTE108R
ES-9001L	QT967SS	QTE967L	
ES-9001R	QT967SS		QTE967R
ES-9328L	QT108SB	QTE108L	

**ISUZU**

ES-9329R	QT108SB		QTE108R
ES-9678L	QT967SS	QTE967L	
ES-9679R	QT967SS		QTE967R
ES-C260411R	QT967SS		QTE967R
8889230850	QT108SB	QTE108L	
8889360850	QT108SB	QTE108L	

\*Only compatible with STEMCO Cross Tube QTT5773

**COMPETITOR # ASSEMBLY LEFT\* RIGHT\***

**ISUZU CONT.**

8889360860	QT108SB		QTE108R
------------	---------	--	---------

**KENWORTH**

817018	QT967SS	QTE967L	
817019	QT967SS		QTE967R
1006148	QT967SS	QTE967L	
1006149	QT967SS		QTE967R
1009009	QT967SS	QTE967L	
1009010	QT967SS		QTE967R
A1-3144F370	QT108SB		QTE108R
A3144C237	QT108SB	QTE108L	
A3144C549	QT108SB	QTE108L	
A3144D238	QT108SB		QTE108R
A3144D524	QT967SS		QTE967R
A3144D550	QT108SB		QTE108R
A3144E525	QT967SS	QTE967L	
A3144F448	QT108SB		QTE108R
A3144G449	QT108SB	QTE108L	
A3144J296	QT108SB		QTE108R
A3144K297	QT108SB	QTE108L	
A3144Q225	QT967SS	QTE967L	
A3144R226	QT967SS		QTE967R
A3144U437	QT108SB	QTE108L	
A3144V438	QT108SB		QTE108R
L24SV5042A12	QT967SS		QTE967R
L24SV5043A12	QT967SS	QTE967L	
L28SV5202A1	QT108SB		QTE108R
L28SV5203A1	QT108SB	QTE108L	

**MACK**

20927689	QT967SS	QTE967L	QTE967R
24424460	QT967SS	QTE967L	QTE967R
25023471	QT108SB	QTE108L	QTE108R
25168559	QT108SB	QTE108L	QTE108R
27191009009	QT967SS	QTE967L	
27191009010	QT967SS		QTE967R
10QH241P1	QT967SS		QTE967R
10QH242P1	QT967SS		QTE967R
10QH243	QT967SS		QTE967R
10QH243P1	QT967SS		QTE967R
10QH243P2	QT967SS	QTE967L	
10QH248P1	QT967SS		QTE967R
10QH248P2	QT967SS	QTE967L	
10QH248P3	QT108SB		QTE108R
10QH248P4	QT108SB	QTE108L	
10QH248P5	QT108SB		QTE108R
10QH248P6	QT108SB	QTE108L	
10QH248P7	QT967SS		QTE967R
10QH309P1	QT108SB	QTE108L	
10QH309P2	QT108SB	QTE108L	
10QH311P1	QT108SB		QTE108R
10QH312P1	QT108SB	QTE108L	
10QH399P1	QT108SB	QTE108L	
18QK214P2	QT108SB		QTE108R
18QK23A	QT108SB		QTE108R
18QK28A	QT108SB	QTE108L	

**COMPETITOR # ASSEMBLY LEFT\* RIGHT\***

**MACK CONT.**

18QK29301	QT108SB		QTE108R
3102285F	QT108SB		QTE108R
3102295F	QT108SB	QTE108L	
70H253P3	QT108SB	QTE108L	QTE108R
70H253P4	QT108SB	QTE108L	QTE108R
70H335	QT108SB	QTE108L	QTE108R
70H335P2	QT108SB	QTE108L	QTE108R
70H335P4	QT108SB	QTE108L	QTE108R
70H335P5	QT108SB	QTE108L	QTE108R
70H337	QT967SS	QTE967L	QTE967R
70H337P2	QT967SS	QTE967L	QTE967R
70H337P3	QT967SS	QTE967L	QTE967R
70H338	QT108SB	QTE108L	QTE108R
70H338P2	QT108SB	QTE108L	QTE108R
70H45	QT967SS	QTE967L	QTE967R
70H47M	QT108SB	QTE108L	QTE108R
70H48	QT967SS	QTE967L	QTE967R
A3144E524	QT967SS		QTE967R
A3144E525	QT967SS	QTE967L	
A3144U438	QT108SB	QTE108L	

**MARMON**

A3144C237	QT108SB		QTE108R
A3144D238	QT108SB	QTE108L	
A3144D524	QT967SS		QTE967R
A3144E525	QT967SS	QTE967L	
A3144J296	QT108SB		QTE108R
A3144K297	QT108SB	QTE108L	
A3144Q225	QT967SS	QTE967L	
A3144R226	QT967SS		QTE967R
L24SV5042A12	QT967SS		QTE967R
L24SV5043A12	QT967SS	QTE967L	

**MCQUAY**

ES187L	QT967SS	QTE967L	
ES187R	QT967SS		QTE967R
ES2040R	QT108SB		QTE108R
ES2041L	QT108SB	QTE108L	
ES2090L	QT108SB	QTE108L	
ES2091R	QT108SB		QTE108R
ES2113R	QT108SB		QTE108R
ES2114R	QT108SB		QTE10

# TIE ROD END INTERCHANGE TO QWIKTIE ASSEMBLY

**COMPETITOR # ASSEMBLY LEFT\* RIGHT\***

**MERITOR CONT.**

A13102V2882	QT108SB	QTE108L	QTE108R
A13102V3454	QT967SS	QTE967L	QTE967R
A13102V4312	QT967SS	QTE967L	QTE967R
A13102W2909	QT108SB	QTE108L	QTE108R
A13102X4288	QT108SB	QTE108L	QTE108R
A13102Y3457	QT967SS	QTE967L	QTE967R
A13102Y3873	QT108SB	QTE108L	QTE108R
A13102Z3458	QT967SS	QTE967L	QTE967R
A13102Z3874	QT108SB	QTE108L	QTE108R
A23102A3459	QT967SS	QTE967L	QTE967R
A23102C3456	QT967SS	QTE967L	QTE967R
A23102F3464	QT967SS	QTE967L	QTE967R
A23102G3465	QT967SS	QTE967L	QTE967R
A23102H4558	QT967SS	QTE967L	QTE967R
A23102I4560	QT967SS	QTE967L	QTE967R
A23102K379	QT967SS	QTE967L	QTE967R
A23102L4380	QT967SS	QTE967L	QTE967R
A23102N3472	QT967SS	QTE967L	QTE967R
A23102P3474	QT967SS	QTE967L	QTE967R
A23102Q4229	QT967SS	QTE967L	QTE967R
A23102R3450	QT967SS	QTE967L	QTE967R
A23102R3476	QT967SS	QTE967L	QTE967R
A23102S3451	QT108SB	QTE108L	QTE108R
A23102T3452	QT967SS	QTE967L	QTE967R
A23102V3454	QT967SS	QTE967L	QTE967R
A23102V4312	QT967SS	QTE967L	QTE967R
A23102W3455	QT967SS	QTE967L	QTE967R
A23102Y3457	QT967SS	QTE967L	QTE967R
A23102Y3483	QT967SS	QTE967L	QTE967R
A23102Y3847	QT108SB	QTE108L	QTE108R
A23102Y3873	QT108SB	QTE108L	QTE108R
A23102Z3458	QT967SS	QTE967L	QTE967R
A23102Z3874	QT108SB	QTE108L	QTE108R
A23144J192	QT967SS	QTE967L	QTE967R
A23144K193	QT967SS	QTE967L	QTE967R
A3144A547	QT108SB	QTE108L	QTE108R
A3144C237	QT108SB	QTE108L	QTE108R
A3144C549	QT108SB	QTE108L	QTE108R
A3144D238	QT108SB	QTE108L	QTE108R
A3144D524	QT967SS	QTE967L	QTE967R
A3144D550	QT108SB	QTE108L	QTE108R
A3144E525	QT967SS	QTE967L	QTE967R
A3144F448	QT108SB	QTE108L	QTE108R
A3144F526	QT967SS	QTE967L	QTE967R
A3144F552	QT967SS	QTE967L	QTE967R
A3144G449	QT108SB	QTE108L	QTE108R
A3144G553	QT967SS	QTE967L	QTE967R
A3144J296	QT108SB	QTE108L	QTE108R
A3144K296	QT108SB	QTE108L	QTE108R
A3144K297	QT108SB	QTE108L	QTE108R
A3144N534	QT967SS	QTE967L	QTE967R
A3144P458	QT967SS	QTE967L	QTE967R
A3144Q225	QT967SS	QTE967L	QTE967R
A3144Q459	QT967SS	QTE967L	QTE967R

**COMPETITOR # ASSEMBLY LEFT\* RIGHT\***

**MERITOR CONT.**

A3144R226	QT967SS	QTE967L	QTE967R
A3144U437	QT108SB	QTE108L	QTE108R
A3144V1088	QT967SS	QTE967L	QTE967R
A3144V1089	QT967SS	QTE967L	QTE967R
A3144V438	QT108SB	QTE108L	QTE108R
A3144W1141	QT967SS	QTE967L	QTE967R
A3144X1142	QT967SS	QTE967L	QTE967R
A3144Z546	QT108SB	QTE108L	QTE108R
A3302V3454V	QT967SS	QTE967L	QTE967R
A33102L4380	QT967SS	QTE967L	QTE967R
A33102N3472	QT967SS	QTE967L	QTE967R
A33102V3454	QT967SS	QTE967L	QTE967R
A33102Z3484	QT967SS	QTE967L	QTE967R
A43102P3370	QT108SB	QTE108L	QTE108R
A4312K3365	QT108SB	QTE108L	QTE108R
A4314D524	QT967SS	QTE967L	QTE967R
A4314N456	QT967SS	QTE967L	QTE967R
R230022	QT108SB	QTE108L	QTE108R
R230023	QT108SB	QTE108L	QTE108R
R230028	QT967SS	QTE967L	QTE967R
R230029	QT967SS	QTE967L	QTE967R
R230041	QT108SB	QTE108L	QTE108R
R230042	QT108SB	QTE108L	QTE108R
R230043	QT967SS	QTE967L	QTE967R
R230050	QT108SB	QTE108L	QTE108R
R230051	QT967SS	QTE967L	QTE967R
R230052	QT108SB	QTE108L	QTE108R
R230055	QT108SB	QTE108L	QTE108R
R230060	QT967SS	QTE967L	QTE967R
R230061	QT967SS	QTE967L	QTE967R
R230066	QT108SB	QTE108L	QTE108R
R230067	QT108SB	QTE108L	QTE108R
R230068	QT967SS	QTE967L	QTE967R
R230069	QT967SS	QTE967L	QTE967R
R230070	QT108SB	QTE108L	QTE108R
R230071	QT108SB	QTE108L	QTE108R
R230072	QT108SB	QTE108L	QTE108R
R230073	QT108SB	QTE108L	QTE108R
R230076	QT108SB	QTE108L	QTE108R
R230077	QT108SB	QTE108L	QTE108R
R230088	QT967SS	QTE967L	QTE967R
R230089	QT967SS	QTE967L	QTE967R
R230090	QT967SS	QTE967L	QTE967R
R230091	QT108SB	QTE108L	QTE108R
R230092	QT108SB	QTE108L	QTE108R
R230102	QT108SB	QTE108L	QTE108R
R230103	QT108SB	QTE108L	QTE108R
R230104	QT108SB	QTE108L	QTE108R
R230105	QT108SB	QTE108L	QTE108R
R230114	QT108SB	QTE108L	QTE108R
R230115	QT108SB	QTE108L	QTE108R
R230127	QT967SS	QTE967L	QTE967R
R230129	QT108SB	QTE108L	QTE108R
R230130	QT108SB	QTE108L	QTE108R

**COMPETITOR # ASSEMBLY LEFT\* RIGHT\***

**MERITOR CONT.**

R230131	QT967SS	QTE967L	QTE967R
R230132	QT967SS	QTE967L	QTE967R
R230133	QT108SB	QTE108L	QTE108R
R230134	QT108SB	QTE108L	QTE108R
R230135	QT967SS	QTE967L	QTE967R
R230136	QT967SS	QTE967L	QTE967R
R230139	QT967SS	QTE967L	QTE967R
R230140	QT967SS	QTE967L	QTE967R
R230145	QT967SS	QTE967L	QTE967R
R230146	QT967SS	QTE967L	QTE967R
R230213	QT108SB	QTE108L	QTE108R
R230214	QT108SB	QTE108L	QTE108R
R230230	QT967SS	QTE967L	QTE967R
R230240	QT967SS	QTE967L	QTE967R
R230241	QT967SS	QTE967L	QTE967R
R230246	QT967SS	QTE967L	QTE967R
R230247	QT967SS	QTE967L	QTE967R
R230408	QT967SS	QTE967L	QTE967R
R230409	QT967SS	QTE967L	QTE967R
R230410	QT967SS	QTE967L	QTE967R
R230413	QT967SS	QTE967L	QTE967R
R230414	QT967SS	QTE967L	QTE967R
R230415	QT967SS	QTE967L	QTE967R
R230416	QT967SS	QTE967L	QTE967R
R230420	QT967SS	QTE967L	QTE967R
R230421	QT967SS	QTE967L	QTE967R
R250354	QT967SS	QTE967L	QTE967R
R250394	QT967SS	QTE967L	QTE967R

**MIDLAND**

M2ES187L	QT967SS	QTE967L	QTE967R
M2ES187R	QT967SS	QTE967L	QTE967R
M2ES2090L	QT108SB	QTE108L	QTE108R
M2ES2091R	QT108SB	QTE108L	QTE108R
M2ES2118L	QT108SB	QTE108L	QTE108R
M2ES2202R	QT108SB	QTE108L	QTE108R
M2ES2208R	QT108SB	QTE108L	QTE108R
M2ES2614R	QT108SB	QTE108L	QTE967R
M2ES3031L	QT108SB	QTE108L	QTE108R
M2ES3030R	QT108SB	QTE108L	QTE108R
M2ES3056	QT108SB	QTE108L	QTE108R
M2ES3057	QT108SB	QTE108L	QTE967R
M2ES3297R	QT108SB	QTE967L	QTE967R
M2ES3298L	QT967SS	QTE967L	QTE967R
M2ES346L	QT108SB	QTE108L	QTE108R
M2ES346R	QT108SB	QTE108L	QTE108R
M2ES411L	QT967SS	QTE967L	QTE967R
M2ES411R	QT967SS	QTE967L	QTE967R
M2ES423L	QT967SS	QTE967L	QTE967R
M2ES423R	QT967SS	QTE967L	QTE967R
M2ES431L	QT108SB	QTE108L	QTE108R
M2ES431R	QT108SB	QTE108L	QTE108R

\*Only compatible with STEMCO Cross Tube QTT5773

**COMPETITOR # ASSEMBLY LEFT\* RIGHT\***

**MISC.**

19093	QT967SS	QTE967L	QTE967R
108846	QT967SS	QTE967L	QTE967R
1005693	QT967SS	QTE967L	QTE967R
1006150	QT967SS	QTE967L	QTE967R
1006151	QT967SS	QTE967L	QTE967R
1006734	QT967SS	QTE967L	QTE967R
21639955	QT967SS	QTE967L	QTE967R
25160398	QT108SB	QTE108L	QTE108R
25161090	QT108SB	QTE108L	QTE108R
370045017	QT967SS	QTE967L	QTE967R

**MOOG**

ES187L	QT967SS	QTE967L	QTE967R
ES187R	QT967SS	QTE967L	QTE967R
ES2040R	QT108SB	QTE108L	QTE108R
ES2041L	QT108SB	QTE108L	QTE108R
ES2090L	QT108SB	QTE108L	QTE108R
ES2091R	QT108SB	QTE108L	QTE108R
ES2113R	QT108SB	QTE108L	QTE108R
ES2114R	QT108SB	QTE108L	QTE108R
ES2115R	QT108SB	QTE108L	QTE108R
ES2116L	QT108SB	QTE108L	QTE108R
ES2118L	QT967SS	QTE967L	QTE967R
ES2202R	QT108SB	QTE108L	QTE108R
ES2203R	QT967SS	QTE967L	QTE967R
ES2204R	QT108SB	QTE108L	QTE108R
ES2207R	QT108SB	QTE108L	QTE108R
ES2208R	QT108SB	QTE108L	QTE108R
ES2209R	QT108SB	QTE108L	QTE108R
ES2210L	QT108SB	QTE108L	QTE108R
ES2215R	QT108SB	QTE108L	QTE108R
ES2614R	QT967SS	QTE967L	QTE967R
ES3030R	QT108SB	QTE108L	QTE108R
ES3031L	QT108SB	QTE108L	QTE108R
ES3041R	QT967SS	QTE967L	QTE967R
ES3056	QT108SB	QTE108L	QTE108R
ES3057	QT108SB	QTE108L	QTE108R
ES3176R	QT967SS	QTE967L	QTE967R
ES3177L	QT967SS	QTE967L	QTE967R
ES3178R	QT967SS	QTE967L	QTE967R
ES3216R	QT967SS	QTE967L	QTE967R
ES3217L	QT967SS	QTE967L	QTE967R
ES3218R	QT967SS	QTE967L	QTE967R
ES3219L	QT967SS	QTE967L	QTE967R
ES3220R	QT967SS	QTE967L	QTE967R
ES3297R	QT967SS	QTE967L	QTE967R
ES3298L	QT967SS	QTE967L	QTE967R
ES3442R	QT967SS	QTE967L	QTE967R
ES3443L	QT967SS	QTE967L	QTE967R
ES346L	QT108SB	QTE108L	QTE108R
ES346R	QT108SB	QTE108L	QTE108R
ES3476	QT967SS	QTE967L	QTE967R
ES3477	QT967SS	QTE967L	QTE967R
ES376L	QT108SB	QTE108L	QTE108R
ES376R	QT108SB	QTE108L	QTE108R

**COMPETITOR # ASSEMBLY LEFT\* RIGHT\***

**MOOG CONT.**

ES411L	QT967SS	QTE967L	QTE967R
ES411R	QT967SS	QTE967L	QTE967R
ES423R	QT967SS	QTE967L	QTE967R
ES431L	QT108SB	QTE108L	QTE108R
ES431LA	QT108SB	QTE108L	QTE108R
ES431LS	QT108SB	QTE108L	QTE108R
ES431R	QT108SB	QTE108L	QTE108R
ES431RA	QT108SB	QTE108L	QTE108R
ES461RS	QT108SB	QTE108L	QTE108R
ES9009	QT967SS	QTE967L	QTE967R

**MOTORCRAFT**

MEOE102	QT108SB	QTE967L	QTE967R
MEOE139	QT967SS	QTE967L	QTE967R
MEOE180	QT108SB	QTE967L	QTE967R
MEOE22	QT967SS	QTE967L	QTE967R

**NAVISTAR**

817018	QT967SS	QTE967L	QTE967R
817019	QT967SS	QTE967L	QTE967R
110362R92	QT967SS	QTE967L	QTE967R
110363R92	QT967SS	QTE967L	

# TIE ROD END INTERCHANGE TO QWIKTIE ASSEMBLY

COMPETITOR #	ASSEMBLY	LEFT*	RIGHT*
<b>O&amp;S MFG.</b>			
ES2040R	QT108SB		QTE108R
ES2041L	QT108SB	QTE108L	
ES2090L	QT108SB	QTE108L	
ES2091R	QT108SB		QTE108R
ES2118L	QT967SS		QTE967R
ES2207R	QT108SB		QTE108R
ES2208R	QT108SB		QTE108R
ES346L	QT108SB		QTE108R
ES346R	QT108SB	QTE108L	
ES376L	QT108SB	QTE108L	
ES376R	QT108SB		QTE108R
ES411L	QT967SS	QTE967L	
ES411R	QT967SS		QTE967R
ES423L	QT967SS	QTE967L	
ES423R	QT967SS		QTE967R
ES431R	QT108SB	QTE108L	

COMPETITOR #	ASSEMBLY	LEFT*	RIGHT*
<b>PAI</b>			
2692235	QT967SS		QTE967R
ARE9950	QT108SB	QTE108L	
ARE9955	QT967SS		QTE967R
ARE9984	QT967SS	QTE967L	
ARE9985	QT967SS		QTE967R
ARE9986	QT108SB		QTE108R
ARE9988	QT967SS		QTE967R
ARE9989	QT967SS	QTE967L	
ARE9990	QT108SB		QTE108R
ARE9991	QT108SB	QTE108L	

COMPETITOR #	ASSEMBLY	LEFT*	RIGHT*
<b>PERFECT CIRCLE</b>			
2692041	QT967SS	QTE967L	
2692042	QT967SS		QTE967R
2692158	QT108SB		QTE108R
2692159	QT108SB	QTE108L	
2692234	QT967SS	QTE967L	
2692235	QT967SS		QTE967R
2692243	QT967SS	QTE967L	
2692244	QT967SS		QTE967R
2692311	QT108SB	QTE108L	
2692312	QT108SB	QTE108L	
2692446	QT108SB	QTE108L	
2692447	QT108SB		QTE108R
2692485	QT108SB		QTE108R
2692644	QT108SB		QTE108R
2692645	QT108SB	QTE108L	
2692653	QT967SS		QTE967R
2692663	QT967SS		QTE967R
2692698	QT108SB	QTE108R	
2692699	QT108SB	QTE108R	
2692700	QT108SB	QTE108R	
2692705	QT967SS		QTE967R
2692709	QT108SB	QTE108R	
2692710	QT108SB	QTE108R	
2693039	QT967SS		QTE967R
2693040	QT967SS	QTE967L	
2695098	QT108SB		QTE108R

COMPETITOR #	ASSEMBLY	LEFT*	RIGHT*
<b>PERFECT CIRCLE CONT.</b>			
2962311	QT108SB		QTE108R
3693034	QT967SS	QTE967L	
S7460	QT967SS		QTE967R
<b>S&amp;S</b>			
S4760	QT108SB		QTE108R
S5048	QT108SB	QTE108L	
S5049	QT108SB		QTE108R
S5056	QT967SS	QTE967L	
S5057	QT967SS		QTE967R
S5988	QT108SB		QTE108R
S6659	QT108SB		QTE108R
S7357	QT967SS		QTE967R
S7358	QT967SS	QTE967L	
S7459	QT967SS	QTE967L	
S7460	QT967SS		QTE967R
S8999	QT967SS	QTE967L	
S9000	QT967SS		QTE967R

COMPETITOR #	ASSEMBLY	LEFT*	RIGHT*
<b>SPICER</b>			
806962	QT967SS	QTE967L	QTE967R
813975	QT967SS	QTE967L	QTE967R
815326	QT967SS	QTE967L	QTE967R
815327	QT967SS	QTE967L	QTE967R
817018	QT967SS		QTE967R
817019	QT967SS		QTE967R
817755	QT108SB	QTE108L	QTE108R
818462	QT967SS	QTE967L	QTE967R
820623	QT108SB	QTE108L	QTE108R
820625	QT108SB	QTE108L	QTE108R
820677	QT108SB	QTE108L	QTE108R
822073	QT108SB	QTE108L	QTE108R
822074	QT108SB	QTE108L	QTE108R
822076	QT108SB	QTE108L	QTE108R
822077	QT108SB	QTE108L	QTE108R
917018	QT967SS	QTE967L	
917070	QT108SB	QTE108L	QTE108R
917086	QT967SS	QTE967L	QTE967R
917088	QT967SS	QTE967L	QTE967R
917090	QT967SS	QTE967L	QTE967R
917092	QT108SB	QTE108L	QTE108R
917094	QT108SB	QTE108L	QTE108R
917138	QT967SS	QTE967L	QTE967R
917190	QT108SB	QTE108L	QTE108R
917134	QT967SS	QTE967L	QTE967R
917443	QT967SS	QTE967L	QTE967R
971814	QT967SS	QTE967L	QTE967R
1005692	QT967SS	QTE967L	QTE967R
1005693	QT967SS	QTE967L	QTE967R
1008060	QT967SS	QTE967L	QTE967R
1008846	QT967SS	QTE967L	QTE967R
1009009	QT967SS	QTE967L	
1009010	QT967SS		QTE967R
1009248	QT967SS	QTE967L	QTE967R
2692244	QT967SS		QTE967R

COMPETITOR #	ASSEMBLY	LEFT*	RIGHT*
<b>SPICER CONT.</b>			
100TR1053X	QT967SS	QTE967L	QTE967R
100TR1054X	QT967SS	QTE967L	QTE967R
100TR1111X	QT967SS	QTE967L	QTE967R
120TR1001X	QT967SS	QTE967L	QTE967R
120TR1002X	QT967SS	QTE967L	QTE967R
120TR1302	QT967SS	QTE967L	QTE967R
140TR1002X	QT967SS	QTE967L	QTE967R
140TR1051	QT967SS	QTE967L	QTE967R
140TR1052	QT967SS	QTE967L	QTE967R
140TR109	QT967SS	QTE967L	
140TR110	QT967SS		QTE967R
140TR111	QT967SS	QTE967L	
140TR112	QT967SS		QTE967R
161TR1003	QT108SB	QTE108L	QTE108R
220TR1003	QT108SB	QTE108L	QTE108R
220TR115	QT108SB		QTE108R
220TR116	QT108SB	QTE108L	
220TR118	QT108SB	QTE108L	
220TR119	QT108SB		QTE108R
220TR1291	QT108SB	QTE108L	QTE108R
220TR1292	QT108SB	QTE108L	QTE108R
SP692311	QT108SB		QTE108R
SP692042	QT967SS		QTE967R
SP692043	QT967SS	QTE967L	
SP692158	QT108SB		QTE108R
SP692159	QT108SB	QTE108L	
SP692234	QT967SS	QTE967L	
SP692235	QT967SS		QTE967R
SP692243	QT967SS	QTE967L	
SP692244	QT967SS		QTE967R
SP692311	QT108SB		QTE108R
SP692485	QT108SB		QTE108R
SP692486	QT108SB	QTE108L	
SP692644	QT108SB		QTE108R
SP692645	QT108SB	QTE108L	
SP692653	QT967SS		QTE967R
SP692698	QT108SB		QTE108R
SP692705	QT967SS		QTE967R
SP692709	QT108SB		QTE108R
SP692710	QT108SB		QTE108R
TRE1878L	QT967SS	QTE967L	
TRE1878R	QT967SS		QTE967R
TRE1875L	QT967SS	QTE967L	
TRE1875R	QT967SS		QTE967R
TRE2090L	QT108SB	QTE108L	
TRE2091R	QT108SB		QTE108R
TRE2118R	QT967SS		QTE967R
TRE2203R	QT967SS		QTE967R
TRE2208R	QT108SB		QTE108R
TRE2614R	QT967SS		QTE967R
TRE3176R	QT967SS		QTE967R
TRE3177L	QT967SS	QTE967L	
TRE3178R	QT967SS		QTE967R
TRE3216R	QT967SS		QTE967R

\*Only compatible with STEMCO Cross Tube QTT5773

COMPETITOR #	ASSEMBLY	LEFT*	RIGHT*
<b>SPICER CONT.</b>			
TRE3312R	QT967SS		QTE967R
TRE3442R	QT967SS		QTE967R
TRE3443L	QT967SS	QTE967L	
TRE346L	QT108SB		QTE108R
TRE346R	QT108SB	QTE108L	
TRE3476R	QT967SS		QTE967R
TRE3477L	QT967SS	QTE967L	
TRE411L	QT967SS	QTE967L	
TRE411R	QT967SS		QTE967R
TRE4318LA	QT108SB	QTE108L	
TRE4318RA	QT108SB		QTE108R
TRE4318LA	QT108SB		QTE108R
TRE4318RA	QT108SB	QTE108L	
TRE476R	QT967SS		QTE967R

COMPETITOR #	ASSEMBLY	LEFT*	RIGHT*
<b>THOMAS BUILT BUSES</b>			
61110153	QT108SB		QTE967R
61110154	QT967SS	QTE967L	

COMPETITOR #	ASSEMBLY	LEFT*	RIGHT*
<b>TRAILMOBILE</b>			
384614	QT967SS	QTE967L	
384615	QT967SS		QTE967R
384616	QT108SB	QTE108L	

COMPETITOR #	ASSEMBLY	LEFT*	RIGHT*
<b>TRP</b>			
TE10001	QT967SS		QTE967R
TE10002	QT967SS	QTE967L	
TE10003	QT967SS		QTE967R
TE11004	QT967SS	QTE967L	
TE11007	QT967SS		QTE967R
TE11008	QT967SS	QTE967L	
TE11981	QT967SS		QTE967R
TE11982	QT967SS	QTE967L	
TE11987	QT967SS		QTE967R
TE11988	QT967SS	QTE967L	
TE12007	QT108SB	QTE108L	
TE12008	QT108SB		QTE108R
TE12011	QT108SB		QTE108R
TE12039	QT108SB		QTE108R

COMPETITOR #	ASSEMBLY	LEFT*	RIGHT*
<b>TRW</b>			
ES3476	QT967SS		QTE967R
ES3477	QT967SS	QTE967L	
ES2040R	QT108SB		QTE108R
ES2041L	QT108SB	QTE108L	
ES2090L	QT108SB		QTE108R
ES2091R	QT108SB	QTE108L	
ES2113R	QT108SB	QTE108L	
ES2114R	QT108SB	QTE108L	
ES2115R	QT108SB	QTE108L	
ES2116L	QT108SB	QTE108L	
ES2118L	QT967SS		QTE967R
ES2202R	QT108SB		QTE108R
ES2204R	QT108SB		QTE108R
ES2207R	QT108SB		QTE108R
ES2208R	QT108SB		QTE108R
ES2209R	QT108SB		QTE108R
ES2210L	QT108SB	QTE108L	

COMPETITOR #	ASSEMBLY	LEFT*	RIGHT*
<b>TRW CONT.</b>			
ES2614R	QT967SS		QTE967R
ES3030R	QT108SB		QTE108R
ES3031L	QT108SB	QTE108L	
ES3033L	QT108SB	QTE108L	
ES3034R	QT108SB		QTE108R
ES3057	QT108SB	QTE108L	
ES3176R	QT967SS		QTE967R
ES3177L	QT967SS	QTE967L	
ES3218R	QT967SS		QTE967R
ES3219L	QT967SS	QTE967L	
ES3220R	QT967SS		QTE967R
ES3297R	QT967SS		QTE967R
ES3298L	QT967SS	QTE967L	
ES3442R	QT967SS		QTE967R
ES3443L	QT967SS	QTE967L	
ES346L	QT108SB</		

# TIE ROD END INTERCHANGE TO QWIKTIE ASSEMBLY

**COMPETITOR # ASSEMBLY LEFT\* RIGHT\***

**TRW CONT.**

L24SV8210A13	QT108SB	QTE108L	
L24SV8210A27	QT108SB		QTE108R
L24SV8211A16	QT108SB		QTE108R
L24SV8211B12	QT108SB	QTE108L	
L24SV8214B15	QT108SB		QTE108R
L24SV8312A13	QT967SS		QTE967R
L24SV8334A14	QT967SS		QTE967R
L24SV8339A12	QT967SS	QTE967L	
L24SV8348A12	QT967SS		QTE967R
L24SV8454A14	QT108SB	QTE108R	
L24SV8454A16	QT108SB	QTE108R	
L24SV8454A19	QT108SB	QTE108R	
L24SV8455A14	QT108SB	QTE108L	
L24SV8455A16	QT108SB	QTE108L	
L24SV8455A19	QT108SB	QTE108L	
L24VT80038AA	QT967SS	QTE967L	QTE967R
L24VT8234C11	QT967SS	QTE967L	QTE967R
L24VT8998A11	QT108SB	QTE108L	QTE108R
L28SV5201A11	QT108SB	QTE108L	
L28SV5201A12	QT108SB	QTE108L	
L28SV5202A11	QT108SB		QTE108R
L28SV5202A16	QT108SB		QTE108R
L28SV5207B16	QT108SB		QTE108R
L28SV5211B23	QT108SB		QTE108R
L28SV5211B37	QT108SB		QTE108R
L28SV5275A12	QT108SB	QTE108L	
L28SV5276A12	QT108SB		QTE108R
L28SV5326A14	QT108SB		QTE108R

**UNIMOTIVE**

TR187L	QT967SS	QTE967L	
TR187R	QT967SS		QTE967R
TR2040R	QT108SB		QTE108R
TR2041L	QT108SB	QTE108L	
TR2090L	QT108SB	QTE108L	
TR2091R	QT108SB		QTE108R
TR2113R	QT108SB		QTE108R
TR2114R	QT108SB		QTE108R
TR2115R	QT108SB		QTE108R
TR2116L	QT108SB	QTE108L	
TR2118L	QT967SS		QTE967R
TR2202R	QT108SB		QTE108R
TR2204R	QT108SB		QTE108R
TR2207R	QT108SB		QTE108R
TR2209R	QT108SB		QTE108R
TR2210L	QT108SB	QTE108L	
TR346L	QT108SB		QTE108R
TR346R	QT108SB	QTE108L	
TR376L	QT108SB	QTE108L	
TR376R	QT108SB		QTE108R
TR411L	QT967SS	QTE967L	
TR411R	QT967SS		QTE967R
TR423L	QT967SS	QTE967L	
TR423R	QT967SS		QTE967R
TR431R	QT108SB	QTE108L	

**COMPETITOR # ASSEMBLY LEFT\* RIGHT\***

**URRESKO**

USK-0004R	QT108SB		QTE108R
USK-0005L	QT108SB	QTE108L	
USK-12007R	QT108SB		QTE108R
USK-12008L	QT108SB	QTE108L	
USK-128187R	QT967SS		QTE967R
USK-12889R	QT967SS		QTE967R
USK-12890L	QT967SS	QTE967L	
USK-13R	QT967SS		QTE967R
USK-147R	QT108SB		QTE108R
USK-14L	QT967SS	QTE967L	
USK-14R	QT967SS		QTE967R
USK-156R	QT108SB		QTE108R
USK-157R	QT108SB		QTE108R
USK-167R	QT108SB		QTE108R
USK-187L	QT967SS	QTE967L	
USK-187R	QT967SS		QTE967R
USK-2090L	QT108SB	QTE108L	
USK-2091R	QT108SB		QTE108R
USK-2203R	QT967SS		QTE967R
USK-2207R	QT108SB		QTE108R
USK-2208R	QT108SB		QTE108R
USK-2290L	QT108SB	QTE108L	
USK-2291R	QT108SB		QTE108R
USK-248P1R	QT967SS		QTE967R
USK-248P2L	QT967SS	QTE967L	
USK-248P3R	QT108SB		QTE108R
USK-248P4L	QT108SB	QTE108L	
USK-248P5R	QT108SB		QTE108R
USK-248P6L	QT108SB	QTE108L	
USK-256 R	QT108SB		QTE108R
USK-2838L	QT967SS	QTE967L	
USK-2838R	QT967SS		QTE967R
USK-2839L	QT967SS	QTE967L	
USK-2839R	QT967SS		QTE967R
USK-3219L	QT967SS	QTE967L	
USK-3220R	QT967SS		QTE967R
USK-3442R	QT967SS		QTE967R
USK-3443L	QT967SS	QTE967L	
USK-411L	QT967SS	QTE967L	
USK-411R	QT967SS		QTE967R
USK-423L	QT967SS	QTE967L	
USK-423R	QT967SS		QTE967R
USK-431L	QT108SB	QTE108L	
USK-431R	QT108SB		QTE108R
USK-502L	QT967SS	QTE967L	
USK-502R	QT967SS		QTE967R
USK-503L	QT108SB	QTE108L	
USK-503R	QT108SB		QTE108R
USK-504R	QT967SS		QTE967R
USK-505R	QT967SS		QTE967R
USK-8084L	QT108SB	QTE108L	
USK-8084R	QT108SB		QTE108R
USK-817755L	QT108SB	QTE108L	
USK-817755R	QT108SB		QTE108R

**COMPETITOR # ASSEMBLY LEFT\* RIGHT\***

**URRESKO CONT.**

USK-9716L	QT108SB	QTE108L	
USK-9716R	QT108SB		QTE108R
USK-AM1066L	QT967SS	QTE967L	
USK-AM1067R	QT967SS		QTE967R
USK-AM1137L	QT108SB	QTE108L	
USK-AM1138R	QT108SB		QTE108R
USK-AM1190L	QT967SS	QTE967L	
USK-AM1191R	QT967SS		QTE967R
USK-AM524R	QT967SS		QTE967R
USK-AM525L	QT967SS	QTE967L	
USK-AM546R	QT108SB		QTE108R
USK-AM547L	QT108SB	QTE108L	
USK-AM552R	QT967SS		QTE967R
USK-AM553L	QT967SS	QTE967L	
USK-AT12889R	QT967SS		QTE967R
USK-ES187L	QT967SS	QTE967L	
USK-ES187R	QT967SS		QTE967R
USK-K844L	QT108SB	QTE108L	
USK-K844R	QT108SB	QTE108L	QTE108R

**VOLVO / WHITE**

111067	QT108SB	QTE108L	
111068	QT108SB		QTE108R
1016903	QT108SB	QTE108L	
1110067	QT108SB		QTE108R
1112811	QT967SS	QTE967L	
1117994	QT967SS	QTE967L	
1117995	QT108SB		QTE967R
3945950	QT108SB	QTE108L	
3945951	QT108SB		QTE108R
3946638	QT967SS	QTE967L	QTE967R
3948202	QT108SB		QTE967R
3948208	QT967SS		QTE967R
3948236	QT108SB	QTE967L	
3948867	QT967SS	QTE967L	
3948868	QT108SB		QTE967R
3948881	QT967SS	QTE967L	QTE967R
3948883	QT967SS	QTE967L	
3948884	QT108SB		QTE967R
27092084	QT967SS	QTE967L	
27092085	QT108SB		QTE967R
85102466	QT108SB		QTE967R
85102535	QT967SS	QTE967L	
85106747	QT967SS	QTE967L	
85106953	QT108SB	QTE108L	
85106954	QT108SB		QTE108R
85110478	QT967SS	QTE967L	
85110479	QT108SB		QTE967R
85111120	QT967SS	QTE967L	QTE967R
85112006	QT108SB		QTE967R
85112007	QT967SS	QTE967L	
370240004	QT967SS	QTE967L	
370240005	QT108SB		QTE967R
370245001	QT108SB	QTE108L	
370245002	QT108SB		QTE108R

\*Only compatible with STEMCO Cross Tube QTT5773

**COMPETITOR # ASSEMBLY LEFT\* RIGHT\***

**VOLVO / WHITE CONT.**

370245009	QT108SB		QTE967R
370245010	QT108SB		QTE967R
370245011	QT967SS	QTE967L	
85102007	QT967SS	QTE967L	
8383088	QT108SB	QTE108L	
839307B	QT108SB		QTE108R
8393088	QT108SB	QTE108L	
A13144F370	QT108SB		QTE108R
A3144C237	QT108SB	QTE108L	
A3144C549	QT108SB	QTE108L	
A3144D238	QT108SB		QTE108R
A3144D524	QT967SS		QTE967R
A3144D550	QT108SB		QTE108R
A3144E525	QT967SS	QTE967L	
A3144J296	QT108SB		QTE108R
A3144J297	QT108SB		QTE108R
A3144K297	QT108SB	QTE108L	
A3144K298	QT108SB	QTE108L	
A3144K298	QT108SB		QTE108R
A3144Q225	QT967SS	QTE967L	
A3144R226	QT967SS		QTE967R
A3144U437	QT108SB		QTE108R
A3144U438	QT108SB	QTE108L	
A3144V437	QT108SB		QTE108R
A3144V438	QT108SB	QTE108L	
V1091562	QT967SS	QTE967L	
V1091563	QT108SB		QTE967R
V1110067	QT108SB	QTE108L	
V1110068	QT108SB		QTE108R
V111067	QT108SB		QTE108R
V111068	QT108SB	QTE108L	
V1112818	QT967SS	QTE967L	

**COMPETITOR # ASSEMBLY LEFT\* RIGHT\***

**WESTERN STAR**

1006148	QT967SS		QTE967R
1006149	QT967SS	QTE967L	
1009009	QT967SS	QTE967L	
1009010	QT967SS		QTE967R
370035029	QT108SB	QTE108L	
370035031	QT108SB		QTE108R
370244412	QT967SS		QTE967R
1436400021	QT108SB	QTE108L	QTE108R
1436400022	QT108SB	QTE108L	QTE108R
1436400036	QT967SS	QTE967L	QTE967R
1436400037	QT967SS	QTE967L	QTE967R
A3144C549	QT108SB	QTE108L	
A3144D550	QT108SB		QTE108R
A3144F448	QT108SB		QTE108R
A3144G449	QT108SB	QTE108L	

**WESTPORT**

143640-005	QT108SB		QTE108R
37025-0004	QT967SS	QTE967L	
37025-0005	QT967SS		QTE967R
839307B	QT108SB		QTE108R
839308B	QT108SB	QTE108L	

**WORKHORSE**

W8001028	QT108SB	QTE108L	
W8001029	QT108SB		QTE108R

## TIE ROD END REFERENCE

QTE967 R – L (small taper – Green cap)  
Thread Diameter 1 1/8" Minor OD on taper 0.967"  
Including ES2203R, ES3442R, ES3443L  
QTE108 R – L (big taper – Red cap)  
Thread Diameter 1 1/4" Minor OD on taper 1.080" Including ES5945R, ES5945L

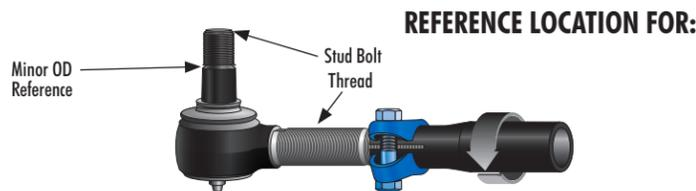

### REFERENCE LOCATION FOR:

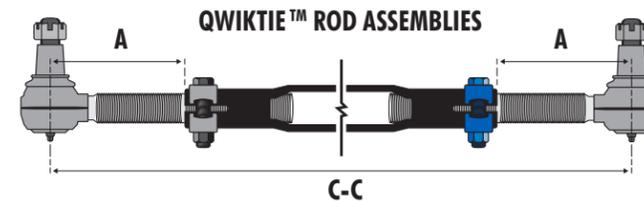

Fit a wide range of configurations,  
QT967SS typical for 12,000 # axles (Green cap)  
QT108SB typical for 16 & 20,000 # axles (Red cap)  
Qwik Tie Assemblies adjust C-C 57 3/8" to 73 1/8"

When extending Rod Ends to the proper C-C  
Maintain equal distance on both Left and Right A=A  
Do not overextend beyond the groove on the thread

## VERSATILE. EFFICIENT. SAFETY.

The QWIKTIE tie rod assembly offers a highly adaptable solution that can accommodate a wide range of tie rod lengths. Increased clamping and tube strength allows it to hold alignment longer, reducing stress on other suspension components.

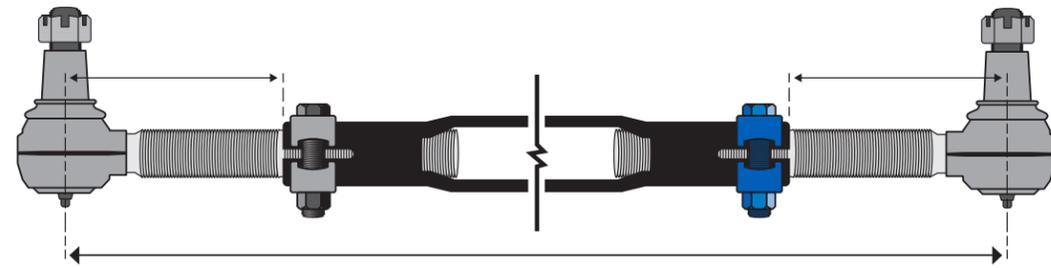

Increased range adjusts to fit over 80% of tie rod assembly lengths in the market (57 3/8" to 73 7/8").

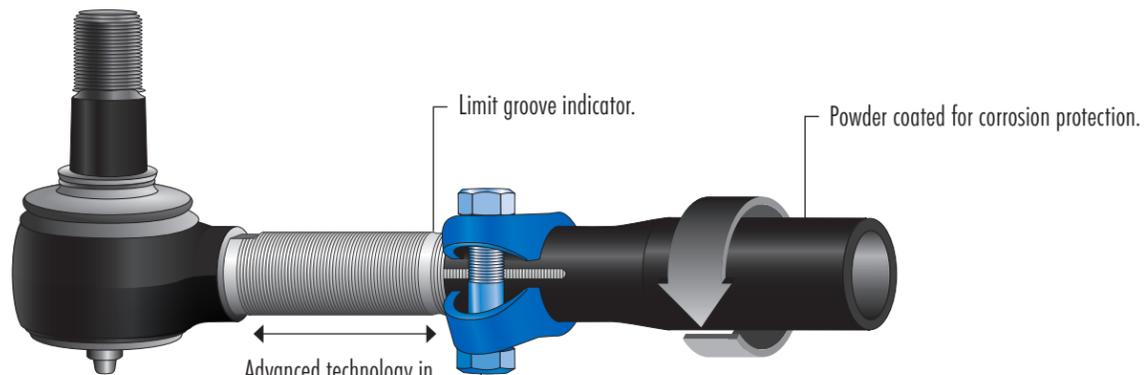

Advanced technology in adjustment design allows greater flexibility to fit a wider selection of tie rod lengths.

Improved clamping system includes a third relief cut to provide tighter clamping strength for a safer and more secure connection.



Finer threads provide more precise adjustment capability.

### QWIKTIE TIE ROD ASSEMBLY

TIE ROD END INDUSTRY STD. REFERENCE NUMBER	QWIKTIE PART NUMBER	AXLE CODE	KING PIN
ES3219L, ES3220R	QT967SS	FF-961, FF-966	K961L
ES423L, ES423R		FF-981, FF-986	K981R
ES9001L, ES9001R		O2-ADD	K120I
ES431L, ES431R	QT108SB	FL-931, FL-941	KH931L
ES9328L, ES9329R		E1462I/W	K147E
ES431L, ES431R		EFA18F3, EFA20F4	K180E

This table captures example cross references to a QWIKTIE tie rod assembly. For any given axle or tie rod end, there can be many possible combinations of cross-tube lengths. For example, there could be as many as 40 different assemblies using the ES423L tie rod end.

## STEMCO SUSPENSION PRODUCTS™

### FRONT STEERING AXLE

STEMCO Kaiser NO REAM king pin repairs do not require the complete removal of the spindle. Tear the unit down until the bushings can be removed. Be sure the spindles are clean and free from burrs prior to installing the bushings. Spiral bushings are easily installed by hand. After bushings are installed use the king pin to check for proper fit and clearance prior to placing the spindle back on the axle. Be sure and follow the installation instruction in the kit.

NO King Pin can repair worn axle or spindle eyes. Axle eyes can be repaired with the

AXLE · PRO · EQUIPMENT

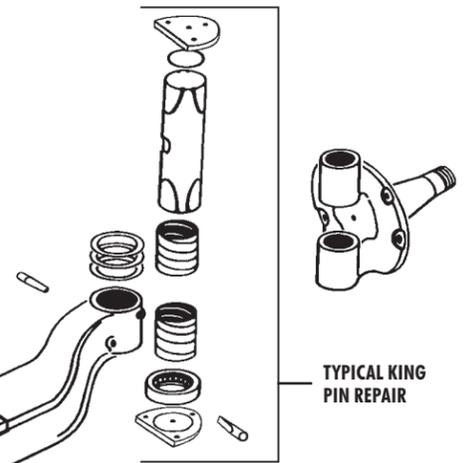

TYPICAL KING PIN REPAIR

### STEMCO KAISER QWIKKITS COME COMPLETE

- A TYPICAL KIT CONSISTS OF:**
- 2 - STEMCO Kaiser king pins
  - 2 or 4 - STEMCO Kaiser bushings
  - 2 - Thrust bearings
  - 1 - Package of steel shim spacers
  - 2 or 4 - Lock pins (depending upon axle design)
  - 4 - End plates and seals
  - 1 - Package of cap screws and washers

STEMCO Kaiser Spiral Steel Bushing must be used with STEMCO Kaiser grease grooved king pin.

### FRONT SPRING SUSPENSION

STEMCO Kaiser grease grooved pins and NO-REAM bushing assemblies with seals will repair all positions on front springs and some rear spring applications.

It is not necessary to remove the spring from the vehicle. Repairing one end of the spring at a time will keep its position with the hanger. Drive out old pin and bushing and clean spring eye. Follow normal installation procedures.

**Check pin in bushing assembly after it has been driven into the spring eye. Pin should not bind in bushing assembly.**

The grooving on the pin provides more grease for better lubrication.

The seals on each end of the assembly keep lubrication in and dirt out. The combination provides longer life and less maintenance between repairs.

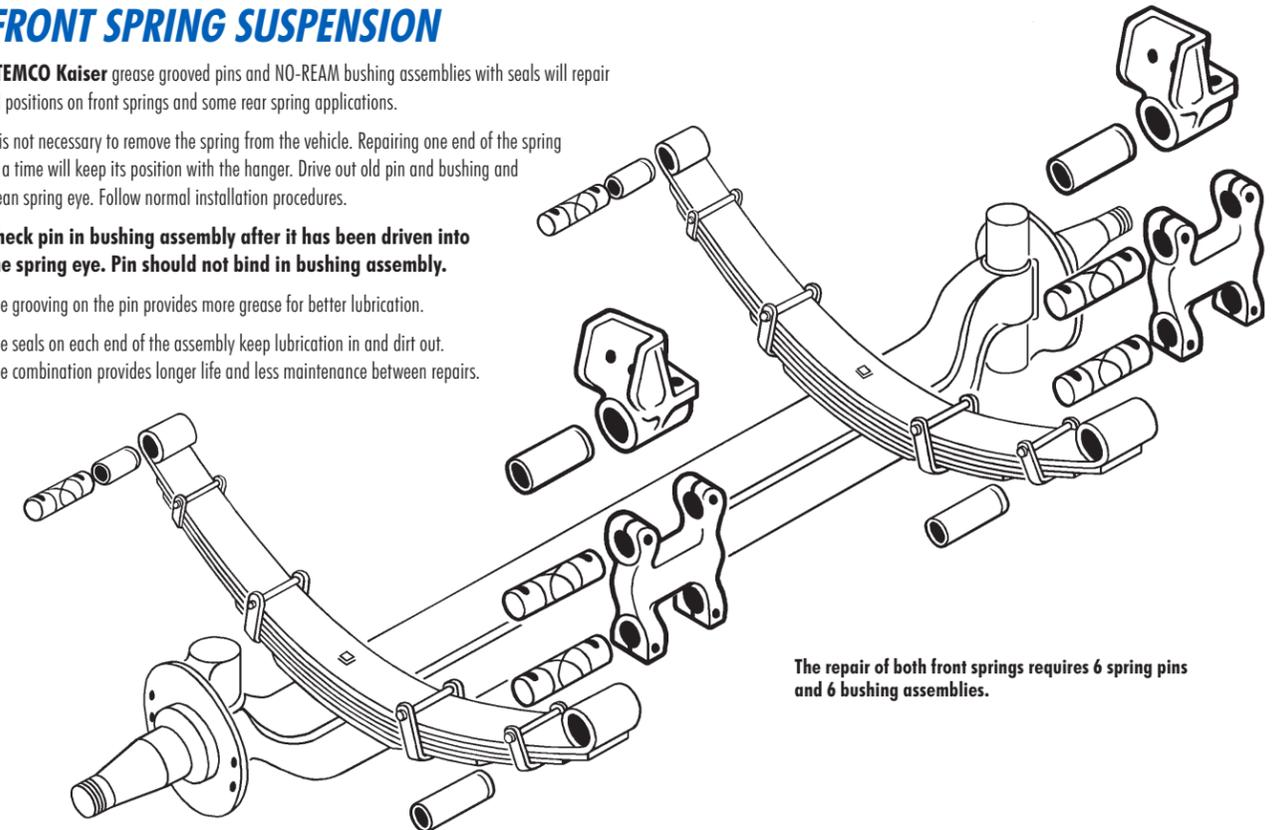

The repair of both front springs requires 6 spring pins and 6 bushing assemblies.



**QWIKKIT®**  
King Pin Kits



**OPTIMALLY-LUBRICATED RAPID-INSTALL KING PINS  
LAST LONGER, MAKING THE ROADWAYS SAFER®**

STEMCO QwikKit® King Pin Kits install faster than reamed king pins, and last up to four times longer than original equipment and aftermarket competitors. A big reason for this longevity is a proprietary design allows for constant lubrication. STEMCO's king pins also showed in the Charpy Impact Test they stand up better to real-life peak loads such as curb strikes. This means they get a truck back on the road more quickly and keep them there over a longer, trouble-free king pin lifecycle.

**Optimal Lubrication**

STEMCO No-Ream steel bushings and pins are grooved to provide an optimal stream of lubrication to high-wear areas.

**Proven Materials**

Proprietary high-chrome, high-carbon tool steel is found only in STEMCO king pins kits, balancing strength and resilience. This means it can withstand the constant turning and pounding placed on the steering knuckle and axle over the life of the vehicle.

**Trained Technicians**

STEMCO authorized technicians receive on-site training and complete technical information.

**The Right Kit**

Our VIN number search can cross-reference vehicles to the correct kit from more than 100 kits for a proper fit.

**Lifecycle Support**

Live technical support is available for all STEMCO products.

**Industry Leading Warranty**

Less than two warranty claims per 10,000 kits.

**Rapid Install**

Faster turn time than reamed king pins.



**PLUSKIT®**  
King Pin Kits



**FOR NO-REAM INSTALLATION, A PERFECT FIT,  
LESS DOWNTIME AND BETTER QUALITY**

STEMCO® PlusKit® has been the premium, no-ream bi-metal king pin kit of choice for over fifteen years. The included presized bi-metal bronze bushings consistently provide the same fit as a tightly reamed king pin installation. The PlusKit is simply the most economical way to replace a king pin. There is no reason to spend thousands on reamers and associated reaming costs. The STEMCO PlusKit makes a simple, precision, reliable and safe king pin replacement a reality.

**Presized Bronze Bushings**

Presized bronze bushings have a fit as good as reamed without the expense.

**Rapid Install**

This kit installs faster with less down time than reaming, making the STEMCO PlusKit the best value in the market.

**Trained Technicians**

STEMCO-authorized technicians receive on-site training and complete technical information.

**The Right Kit**

For a proper fit, our VIN number search can cross-reference vehicles to identify the correct kit from more than 60 kits.

**Life-Cycle Support**

Live technical support is available for all STEMCO products.



# STEMCO®

## SUSPENSION PRODUCTS

# STEMCO®

## EQUIPMENT



AXLE · PRO · EQUIPMENT  
**APE**

### EVERYTHING NEEDED FOR AXLE EYE REPAIR

Only the STEMCO® Axle Pro Equipment™ (APE) package offers everything needed to enhance worn axle eyes. This revolutionary piece of equipment comes with mounting brackets, a magnetic-based drill, coolant and safety equipment. When looking for an affordable, simple and quick way to enhance worn axle eyes, choose the STEMCO APE.

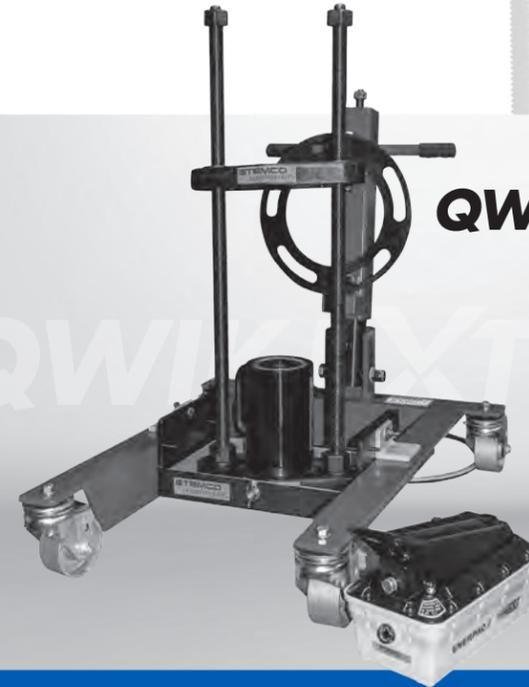

**QWIKEXTRACT®**

### THE KING OF KING PIN REMOVAL SYSTEMS INTEGRATED CART AND SELF-ALIGNING PRESS FOR FAST, SAFE CHANGES

Designed by mechanics, for mechanics, the all-new STEMCO QwikExtract® king pin removal system combines the speed and safety of a self-aligning, powerful removal press with a mobile wheel-end cart. The self-aligning system keeps the push rods lined up with the king pin for the fastest, most effective king pin removal in the industry. No need for wheel end tear down!



#### Complete

APE's universality allows customization to best suit shop needs and contains all components needed to enhance worn axle eyes.

#### Fast

Repairs can be made without removing the axle to be able to enhance the axle eyes in just minutes.

#### Valuable

APE's mobility enables axle repairs to be made outside the shop, allowing for a quick return on investment.

#### Durable

Proven revolutionary system with options that allow for continuous release of new applications.

#### Simple

Provides a simple, easy and reliable process to address worn axle eyes to assist in achieving maximum axle eye life.

#### Convenient

Wheel end cart allows the brake drum, hub and their components to be moved out of the way together during the operation.

#### Reduces Strain

Eliminates operator strain and potential for injury from lifting or falling components.

#### Versatile

Interchangeable hub mounts accommodate most wheel end configurations.

#### Powerful

Industrial-quality hydraulic press removes the most stubborn king pins.

#### Strong

Holds up to 350 lbs.

#### Small Footprint

Ideal for working in tight spaces.

  
**STEMCO®**  
A Higher Standard of Performance.™  
an EnPro Industries company

Making the Roadways Safer®

  
**STEMCO®**  
A Higher Standard of Performance.™  
an EnPro Industries company

Making the Roadways Safer®





## Making the Roadways Safer®

**United States | 800-527-8492 | 903-758-9981**  
300 Industrial Boulevard  
Longview, Texas 75602 | US

**Canada | 877-232-9111 | 905-206-9700**  
5775 McLaughlin Road  
Mississauga, Ontario L5R 3P7 | Canada

[stemco.com](http://stemco.com)

**Mexico | 444-804-1736**  
Eje Central Sahop No 215, Zona Ind  
San Luis Potosi SLP 78395 | Mexico

**Australia | 011-61-2-9793-2599**  
Unit 6 CNR Rookwood & Muir Roads  
Yagoona NSW 2199 | Australia

**STEMCO Tech Line | 800-527-8492**

STEMCO, STEMCO Kaiser, QWIKTIE, QwikKit, QwikExtract, APE, PlusKit, Econo Kit, BSP, BSA, and LubraFlex are trademarks of STEMCO Products Inc. © 2018 STEMCO Products Inc. Printed in the USA. Part No. 577-0002 | Rev. 10/18



an EnPro Industries company