

Moisture Ejector Installation on Typical Automotive and Stationary Mountings

Instructions for properly connecting STEMCO Moisture Ejector valve to unloader port of compressor governors

How the product operates:

1. The STEMCO Moisture Ejector is connected at the air tank drain with a special 1/4" N.P.T. nipple which is included with ejector.
2. The actuating end connects to the governor unloader port or brake actuating line. Arrows in Figure 1 indicate unloading ports on 3 widely used governors.
3. The STEMCO Moisture Ejector operates automatically each time the air compressor "cuts in" and "cuts out" when connected to the governor unloader port (see Figures 2 & 3). A. Air tank pressure furnishes blow-off power. B. Up to three ounces (or 5.42 cubic inches) of liquid material can be ejected each time the ejector operates. C. The powerful valve action also ejects foreign material, carbon compounds, and alkali scales which form in air systems.

FIGURE 1

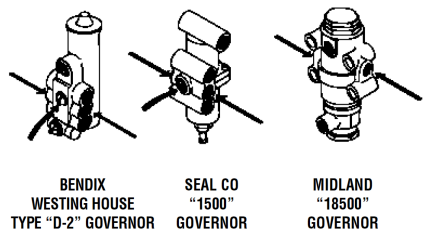

FIGURE 2: Compressor Cutting "IN"

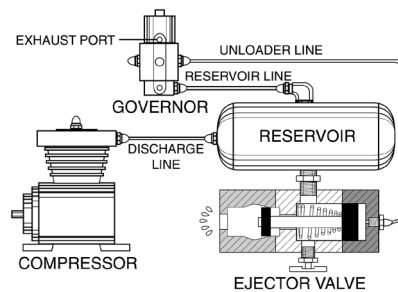
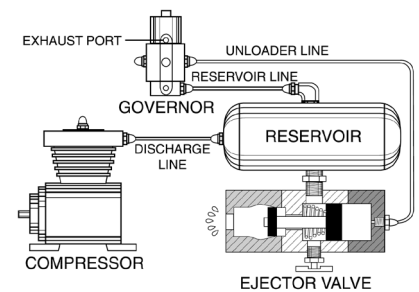

FIGURE 3: Compressor Cutting "OUT"



Installation:

The Stemco Moisture Ejector is most commonly installed at the wet or primary reservoir drain port. Remove manual drain valve and install Stemco Moisture Ejector with special 1/4" N.P.T. nipple which is included with valve. Recommended actuator line is 1/4" O.D. tubing which connects from the actuating port of the Stemco Moisture Ejector to the unloader port of the governor.

FIGURE 4: Typical Installation on a stationary compressed air system

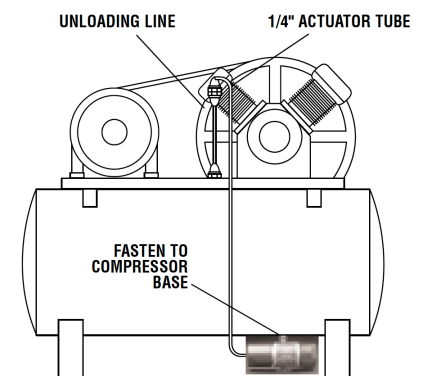

Moisture Ejector Installation on Typical Automotive and Stationary Mountings

Some air compressors have no unloader or governor at all; therefore, by adding a few simple components, a STEMCO Moisture Ejector can be used in these applications. A pressure switch and an electrically actuated solenoid valve will provide a signal to actuate the moisture ejector in this type of application. A pressure switch will need to be added if one has not been previously provided by the air compressor manufacturer. The other primary component required is a normally closed 3-way solenoid valve rated for at least 200 p.s.i. (one such solenoid valve is offered by the Granger Co. under stock no. 5A541). The remaining components required are 1/4" N.P.T. tee, several N.P.T. to air line adapters, and several feet of 1/4" tubing rated for at least 200 p.s.i.

Refer to the following steps for installation of the STEMCO Moisture Ejector:

1. Shut off power to the air compressor at the breaker box.
2. Drain all pressure off the tank.
3. Disconnect the pressure switch from the port on the compressor.
4. Connect a 1/4" N.P.T. pipe tee to the port which contained the pressure switch.
5. Using a coupling, reconnect the pressure switch to one side of the tee.
6. Using a coupling, connect port 2 of the solenoid valve to the other side of the tee.
7. Mount the moisture ejector to the drain port of the air tank using the special fitting provided with the ejector.
8. Using adapter fittings, route tubing from port 1 of the solenoid valve to the inlet port of the moisture ejector.
9. Wire one lead of the solenoid valve to the pressure switch.
10. Wire the other lead of the solenoid to neutral.
11. Turn on the power to the air compressor and test operation thoroughly.

Remove cover from pressure switch to attach wires from solenoid

