

TECHNOLOGICALLY ADVANCED SEALING SOLUTIONS



Easy Installation

The single piece, unitized design is installed in one step using the yoke bolt to install the press-fit OD.

Repair Sleeves Not Required

The unitized design incorporates a wear ring to provide an ideal running surface for the sealing lip, thus eliminating the need for repair sleeves that often change the seal lip angle during operation, resulting in reduced life.

Eliminate Yoke Wear

Sealing lips are contained in a manner that prevents yoke surface contact from the lip. New yokes will remain new at the sealing point.

Repair 'Grooved' Yokes

The patented SMART features of STEMCO's Unitized Pinion Seal make most yokes reusable due to the wide contact area of the ID.

Eliminate Leak Paths

Bore sealant on the OD and the wide contact area on the ID eliminate leak paths to avoid premature failures.

Reduce Contamination Failures

To promote long life, a labyrinth path with multiple dust lips prevents contamination ingress into the sealing lip and oil.

Long-Life Performance

Fluoroelastomer rubber on the main sealing lip withstands the high heat consistent with pinion seal applications.

UNITIZED PINION SEAL

SPECIFICATIONS & INTERCHANGE



A Higher Standard of Performance.SM
an EnPro Industries company

PART NUMBER/ APPLICATION	BORE ID/ YOKE SHAFT OD	TOOL NUMBER	OE NUMBER	SKF NUMBER	NATIONAL NUMBER	DESIGN TYPE
STEMCO No. 429-0002 Mack Front Input	4.500/ 3.500	551-5360	88AX458	34882 34891	415991N	1
STEMCO No. 429-0003 Eaton 400 Rear Input	4.564/ 2.625	551-5001	127721 79470	26373 26378	9773	2
STEMCO No. 429-0004 Eaton 400 Front Output, Eaton 344, 404, 405, 454 Front Output	3.625/ 2.625	551-5003	127720 63910 127592	26200 26209 26239 26762	475003N	3 3
STEMCO No. 429-0005 Meritor SQ100 Front Input	3.751/ 3.003	551-5004	A11205Y2729 A1205P2590	29865 29867 30007	4810V 100495 415281N	1
STEMCO No. 429-0006 Eaton 402 Front Input Eaton 40, 461-653 series Front Output	4.003/ 2.937	551-5002	127719 A1205U1737 210737	29292 29322 29316 29380	416654 475012N	3
STEMCO No. 429-0007 Meritor R145/160 Front Input	4.249/ 3.253	551-5006	A11205X2728 A1205R2592 A1205P1368	32385 32397 32410	4543V 100494 416470N	1
STEMCO No. 429-0008 Mack Front Output	3.537/ 2.751	551-5007	88AX456 A1205A1925	27295 27558	4874N 475322N	1
STEMCO No. 429-0009 Mack Rear Input	3.996/ 2.751	551-5008	88AX457	27542 27565	415272N	1
STEMCO No. 429-0010 Meritor SQ100 Rear Input	4.935/ 3.003	551-5009	A11250Z2730 A1205N2588 A1205H2426	30145 30153	3905 4562V 100263	2
STEMCO No. 429-0011 Meritor RT 46-160, 180, 380 Series	5.501/ 3.253	551-5011	A1205Q2591	32870	4544V 100557	2
STEMCO No. 429-0012 Eaton 344, 404, 405 & 454 Front and Rear Input	4.564/ 3.000	551-5012	127591	29528		2
STEMCO No.*429-0013 Eaton 40, 461-653 series Rear Input	5.042/ 2.938	551-5013	210724	29381		3
STEMCO No.*429-0014 Eaton 40, 461-653 series Front Input	4.376/ 3.375	551-5014	210736	33751		3

* Check for availability

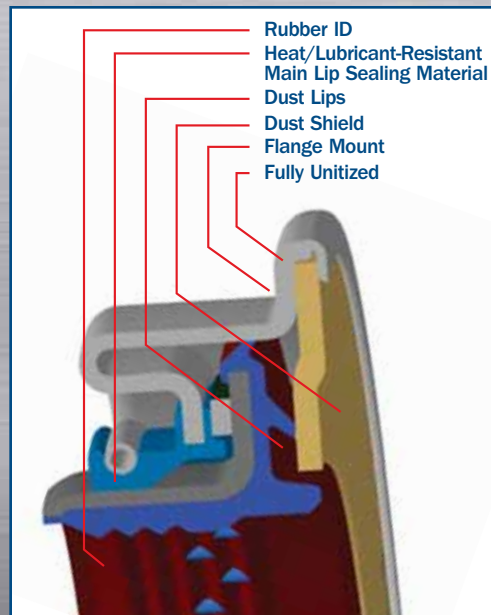
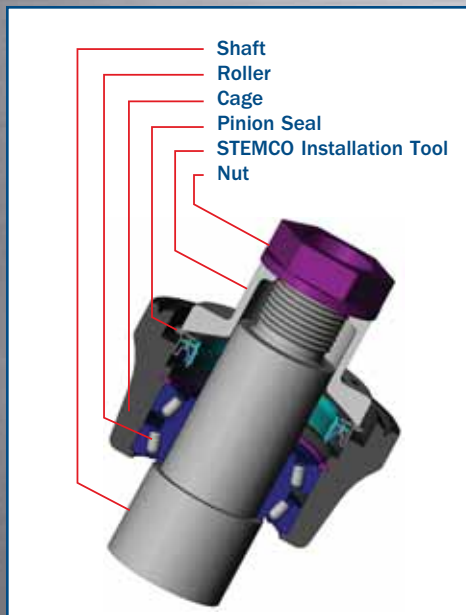

DESIGN TYPES

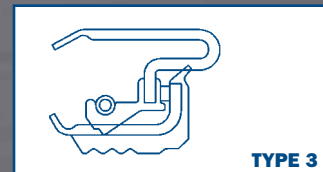
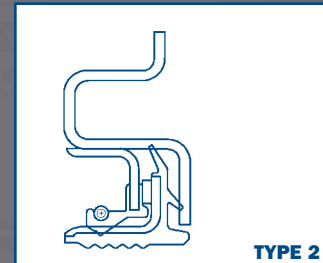
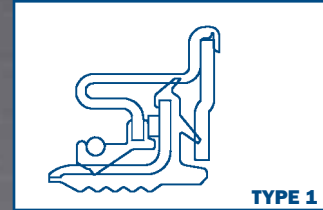

STEMCO LP - USA
P.O. Box 1989 · Longview, TX 75606-1989
(903) 758-9981 · 1-800-527-8492 · FAX: 1-800-874-4297
www.stemco.com

STEMCO - Canada
5900 Ambler Drive, Units 4 & 5 · Mississauga, ON L4W 2N3
(905) 206-9922 · 877-232-9111 · FAX: 877-244-4555

ISO 9001:2000 & ISO/TS 16949
STEMCO is a registered trademark
of STEMCO LP ©2008 STEMCO LP
Printed in the USA · Part No. 571-3069
Hudson 10-547 · 10/08

